

fischertechnik 

ROBOTICS

Bauanleitung
Assembly instruction
Instructions de montage
Bouwhandleiding
Instrucciones de construcción
Manual de montagem
Istruzioni di montaggio
Инструкция по сборке
安装说明书

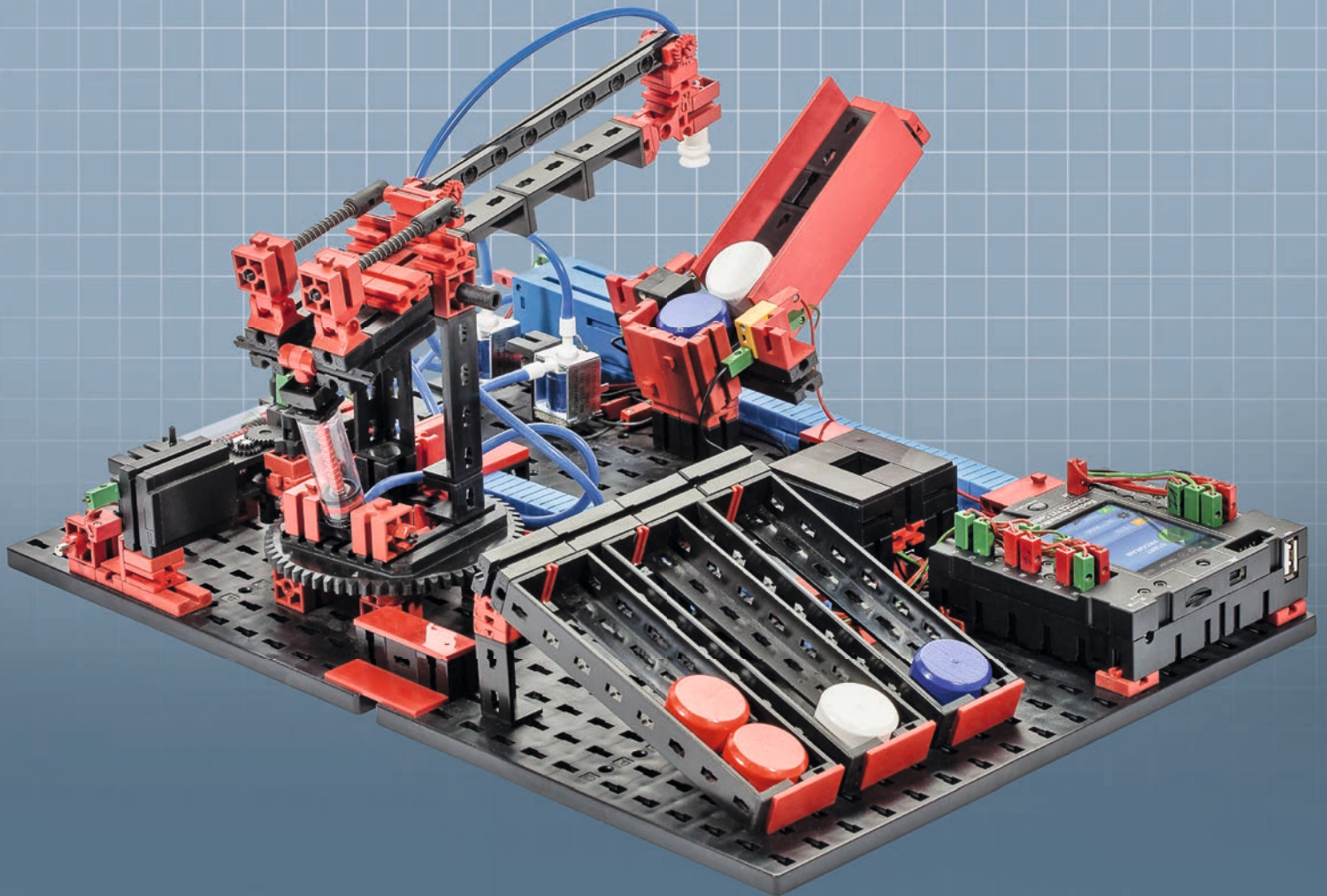

TXT *ElectroPneumatic* **4 MODELS**
Robotics & Electropneumatics

Inhalt
Contents
Contenu

Inhoud
Contenido
Conteúdo

Contenuto
Содержание
目录

Einzelteilübersicht / Spare parts list / Liste des pièces détachées / Onderdelenoverzicht / Lista da piezas / Resumo de peça individual /
Singoli componenti / Перечень деталей / 零件概览 1

Montagetipps / Tips for assembly / Tuyaux pour le montage / Montagetips / Consejos para el montaje / "Dicas" para montagem /
Consigli per il montaggio / Советы по сборке / 装配建议 3

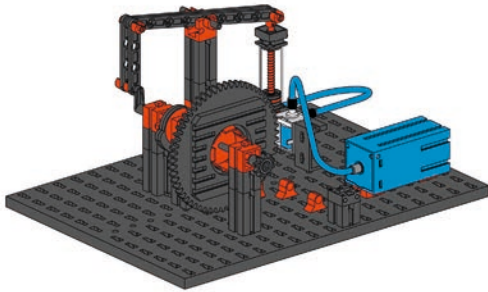

Druckluftmotor / Compressed air motor / Moteur
pneumatique / Persluchtmotor / Motor de aire comprimido /
Motor de ar comprimido / Motore ad aria compressa /
пневмомотор / 压缩空气马达 6

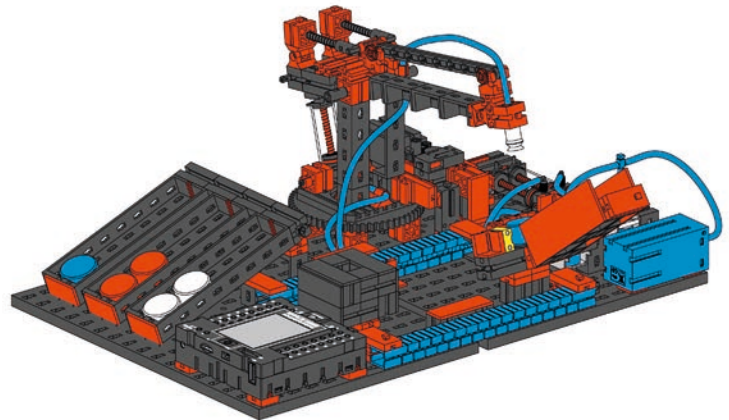

Farbsortierroboter / Color sorting robot / Robot de triage
des couleurs / Kleurensorteerrobot / Robot clasificador por
colores / Robo seleccionador de cores / Robot assortitore di
colori / Робот-цветосортировщик /
辨色分选机器人 10

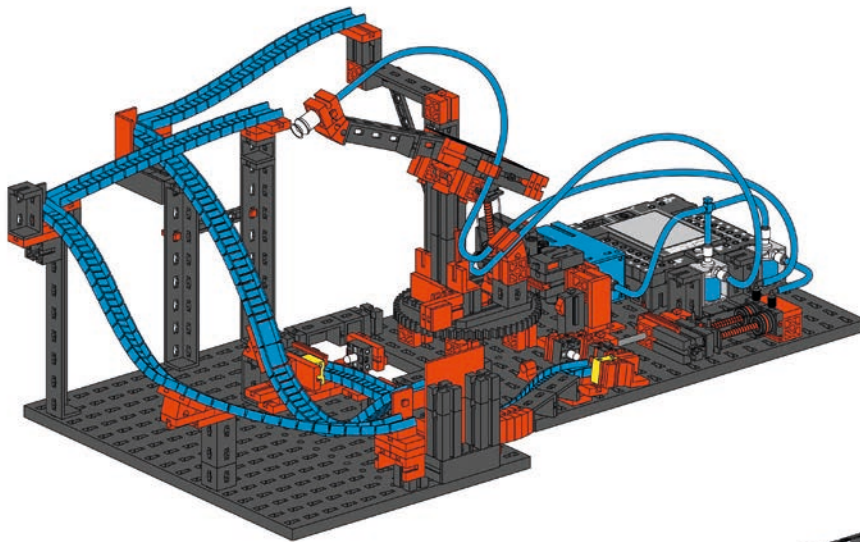

Kugelparcours mit Vakuumgreifer / Ball obstacle course
with vacuum picker arm / Parcours à billes avec grappin
pneumatique / Kogelparcour met vacuümgreijper /
Pista de recorrido de bola con manipulador de vacío /
Circuito de esferas com agarrador a vácuo / Percorso
sfere con pinza a ventosa / Трасса для
шарика с вакуумным захватом /
配分选机器人的滚珠弯道 22

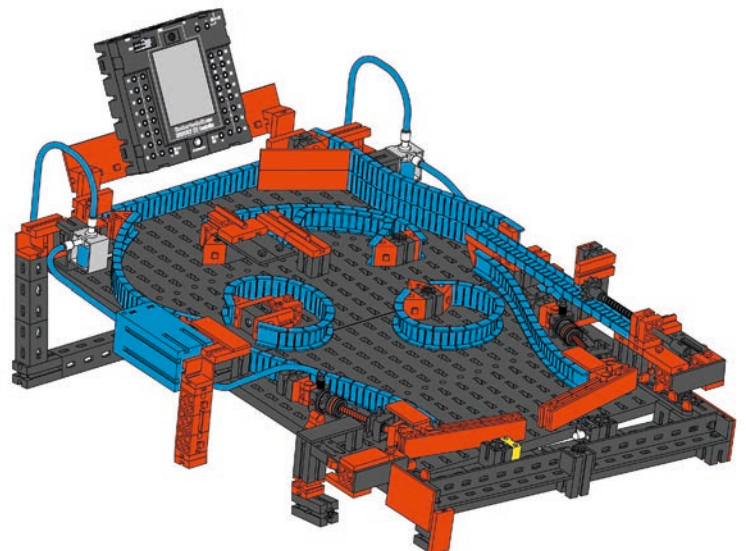

























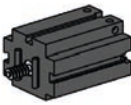











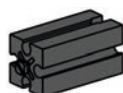



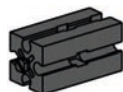











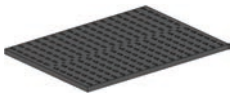













Flipper / Pinball machine / Flipper / Flipper /
Pinball / Flipper / Flipper / пинбол-машина /
弹球机 34



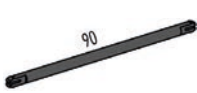

Einzelteilübersicht
Spare parts list
Liste des pièces détachées

Onderdelenoverzicht
Lista da piezas
Resumo de peça individual

Singoli componenti
Перечень деталей
零件概览







 60°	31 010 10 x	 15°	31 981 4 x		35 073 2 x		36 922 3 x
 30°	31 011 4 x		31 982 25 x		35 088 1 x		36 950 4 x
 90	31 040 1 x		32 064 17 x		35 327 2 x	 60	36 952 1 x
	31 058 2 x	 7.5°	32 071 13 x		35 328 5 x		37 034 1 x
 15	31 060 5 x		32 293 1 x		35 945 2 x		37 157 1 x
 30	31 061 5 x		32 330 5 x		35 969 3 x		37 237 28 x
	31 078 1 x		32 850 7 x		36 134 2 x		37 238 3 x
	31 082 1 x		32 879 10 x		36 227 2 x		37 468 18 x
 45	31 330 2 x		32 880 2 x	 9V ...	36 293 6 x		37 636 2 x
	31 390 1 x		32 881 24 x	 4	36 323 8 x		37 679 6 x
	31 391 1 x		32 882 6 x		36 334 2 x		37 727 2 x
	31 422 1 x		32 985 2 x		36 532 1 x		37 783 2 x
	31 426 6 x		35 031 2 x		36 911 2 x		38 216 1 x
	31 436 6 x		35 049 23 x	 45	36 913 2 x		38 240 7 x
	31 597 2 x	 30	35 063 1 x		36 915 3 x		38 241 7 x
	31 642 2 x	 60	35 065 5 x		36 920 11 x		38 242 3 x
	31 690 2 x	 90	35 066 1 x		36 921 2 x		38 245 2 x

Einzelteilübersicht
Spare parts list
Liste des pièces détachées

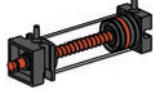

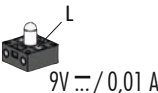

	38 246 3 x
	38 248 2 x
	38 251 2 x
	38 261 6 x
	38 414 1 x
	38 423 3 x
	38 428 3 x
	38 464 2 x

Onderdelenoverzicht
Lista da piezas
Resumo de peça individual

	38 546 2 x
	121 470 1 x
	121 640 1 x
	121 641 11 x
	122 363 1 x
	122 409 1 x
	128 599 1 x
	132 875 2 x

	133 027 3 x
	133 028 1 x
	144 262 2 x
	162 135 2 x
	174 622 2 x
	174 623 2 x
	174 624 2 x
	174 625 2 x

Singoli componenti
Перечень деталей
零件概览

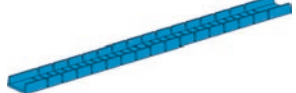
	174 626 2 x
	174 627 2 x
	181 583 19 x
	181 584 20 x
<p>Erfinder Flexprofil Art.-Nr. 121 641: Design und Konzeption Andreas Lehrberger</p> 	

Montagetipps
Tips for assembly
Tuyaux pour le montage

Montagetips
Consejos para el montaje
"Dicas" para montagem

Consigli per il montaggio
Советы по сборке
装配建议

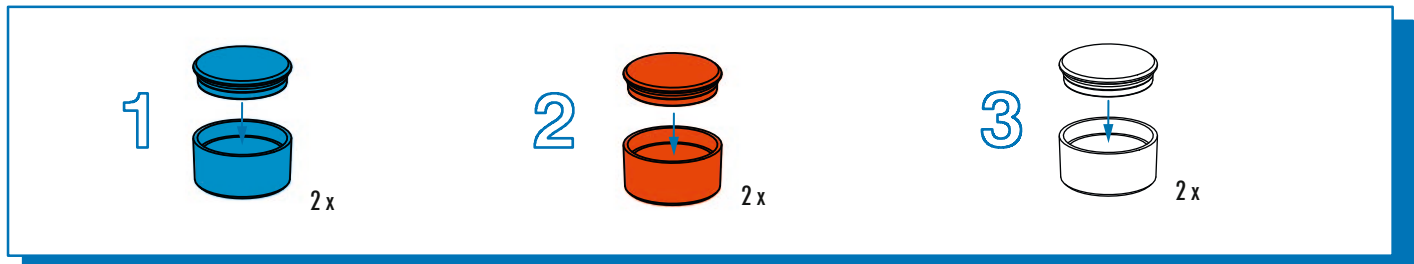
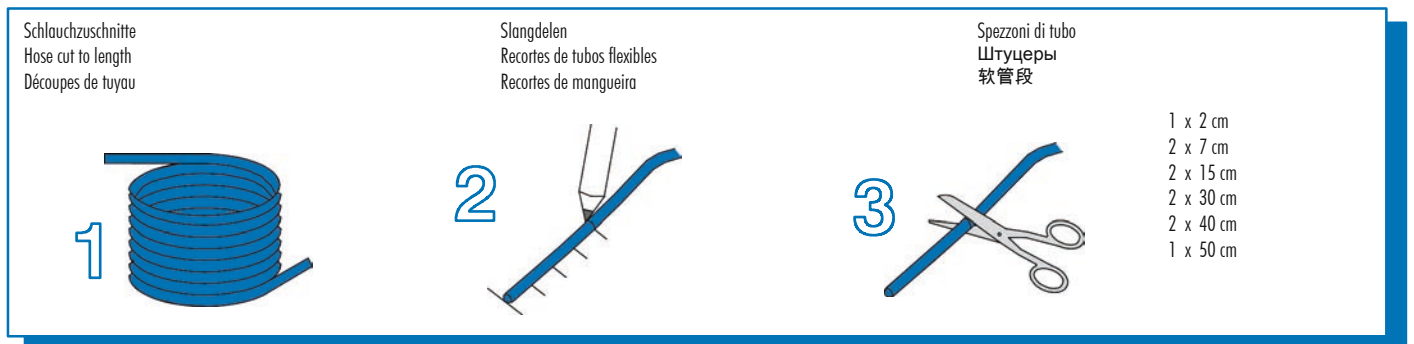
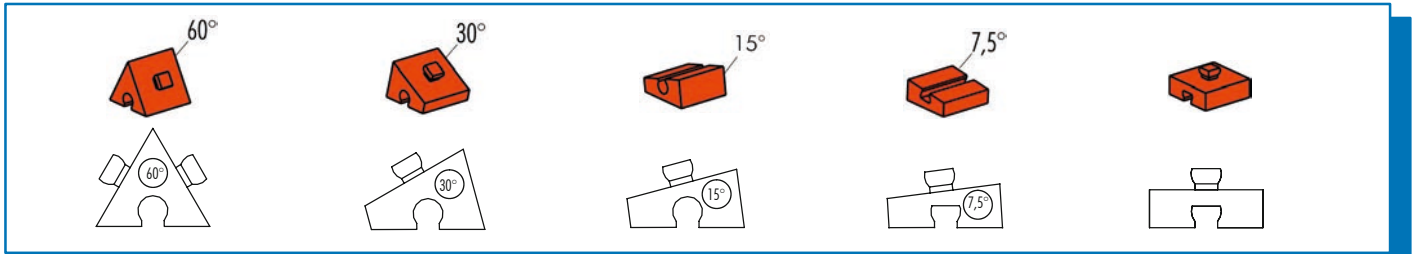
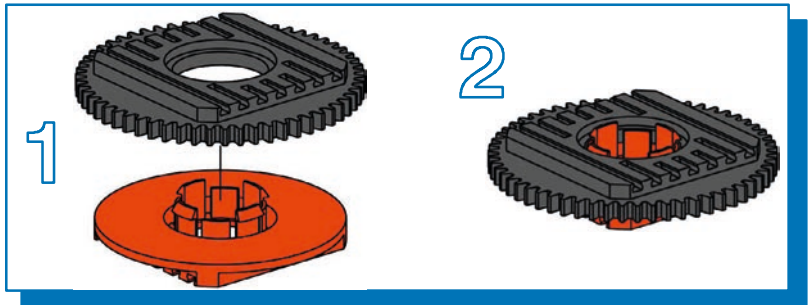
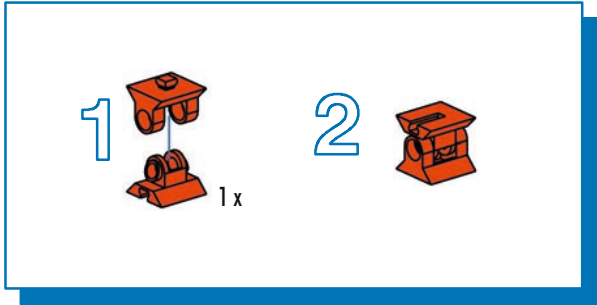

25 cm
 20 cm
 15 cm
 10 cm
 5 cm
 0

Montagetipps
Tips for assembly
Tuyaux pour le montage

Montagetips
Consejos para el montaje
"Dicas" para montagem

Consigli per il montaggio
Советы по сборке
装配建议

Kabel und Stecker
Plugs and cables
Fiches et des câbles

Stekkers en cables
Enchufes en cables
Cabos e contatos

Cavi e connettori
Провода и штекеры
电缆和插头

0 3cm

1
1 x 20 cm
3 x 35 cm
4 x 55 cm

2
3cm 3cm

3
1 x 20 cm

4

5
3 x 35 cm
4 x 55 cm
2 x 20 cm

3/2-Wege-Magnetventil
3/2 Way Magnetic Valve
Distributeur électromagnétique à 3/2 voies

3/2-weg magneetklep
Válvula electromagnética de 3/2 vías
Válvula magnética de 3/2 vías

Distributore elettromagnetico a 3/2 vie
3/2-ходовой электромагнитный клапан
两位三通电磁阀

1
2 cm 2 cm

2

3

4

5
2 x
9-12 V DC / 130 mA

Sicherheitshinweise
Safety Information
Consignes de sécurité

Veiligheidsrichtlijnen
Indicaciones de seguridad
Observações sobre segurança

Informazioni per la sicurezza
Указания по технике безопасности
安全指南

- Alle Einzelteile, insbesondere bewegliche Teile sind falls notwendig zu warten und zu reinigen.
- All components, especially moving parts, should be maintained and cleaned as necessary.
- Toutes les pièces détachées et en particulier les pièces mobiles, sont, si nécessaire, à entretenir et à nettoyer.
- Alle onderdelen, vooral de bewegende delen, kunnen, indien noodzakelijk, onderhouden en gereinigd worden.
- Es necesario limpiar y mantener en buen estado todas las diferentes piezas - especialmente las piezas móviles.
- Caso necessário, todas as peças individuais, especialmente peças móveis, tem que ser submetidas à manutenção e ser limpadas.
- Se necessario, tutti i singoli componenti, soprattutto le parti mobili, si devono eventualmente sottoporre a manutenzione e pulizia.
- Все детали, особенно подвижные, требуют ухода и чистки.
- 必要时应保养和清洁所有零件，尤指运动部件。

Sicherheitshinweise Safety Information Consignes de sécurité

Veiligheidsrichtlijnen Indicaciones de seguridad Observações sobre segurança

Informazioni per la sicurezza Указания по технике безопасности 安全指南

- Die Anschlussklemmen dürfen nicht kurzgeschlossen werden.
 - Drähte nicht in Steckdose einführen!
 - Ladegerät regelmäßig auf Schäden überprüfen.Bei einem Schaden darf das Ladegerät bis zur vollständigen Reparatur nicht mehr verwendet werden.
- Alle elektrischen Bauteile (Motoren, Lampen, ROBO TXT Controller) dürfen ausschließlich an Stromversorgungen von Fischertechnik angeschlossen werden.
- Do not short circuit the connecting terminals!
 - Do not insert the wires into an outlet!
 - Regularly inspect battery charger for damage. If the battery charger has been damaged, it should not be used further until fully repaired.
 - No electrical components (motors, lamps, ROBO TXT Controller) are to be connected to any other power supply than that provided by Fischertechnik.
- Il est interdit de court-circuiter les bornes de raccordement.
 - Contrôlez régulièrement le chargeur en vue d'éventuelles détériorations
 - En cas de détérioration, il est interdit d'utiliser le chargeur jusqu'à ce qu'il ait été intégralement réparé
 - Tous les composants électriques (moteurs, lampes, ROBO TXT Controller) ne doivent être branchés aux alimentations électriques uniquement que par la société Fischertechnik.
- Los bornes de conexión no pueden ser puestos en cortocircuito.
 - No introducir hilos en la toma de corriente!
 - Comprobar con regularidad si el cargador presenta daños. En caso de presentar daños, el cargador no debe volver a ser utilizado hasta que esté completamente reparado.
 - Todos los componentes eléctricos (motores, luces, ROBO TXT Controller) deben conectarse a la alimentación de corriente de la técnica Fischer exclusivamente.
- Os terminais de conexão não devem ser curto-circuitados.
 - Nunca introduzir fios na tomada!
 - Verificar regularmente se o carregador apresenta danos. Em caso de dano, o carregador não deverá ser utilizado enquanto não estiver plenamente consertado.
 - Todas as peças componentes elétricas (motores, lâmpadas, ROBO TXT Controller) só podem ser exclusivamente conectadas em abastecimentos de corrente da Fischertechnik.
- I morsetti di allacciamento non devono essere cortocircuitati.
 - Non inserire i fili nella presa elettrica.
 - Controllare periodicamente se il caricabatterie presenta dei danni. In caso di danni, il caricabatterie non deve più essere utilizzato fino alla riparazione.
 - Tutti i componenti elettrici (motori, lampadine, ROBO TXT Controller) devono essere collegati esclusivamente ad alimentatori Fischertechnik.
- Не замыкайте накоротко соединительные клеммы.
 - Не вставляйте в розетку провода!
 - Регулярно проверяйте зарядное устройство на отсутствие повреждений. При наличии повреждений использовать зарядное устройство до выполнения его полного ремонта не разрешается.
 - Все электрические детали (электромоторы, лампочки.) можно подключать только к источникам электропитания от Fischertechnik.
- 接线柱不允许被短路。
 - 禁止将金属丝插入插座！
 - 经常检查充电器是否有损坏情况。如果充电器有损，直到完全修好为止不可以再使用。
 - 只允许将所有电气部件（传感器，电机）与慧鱼技术产品的电源装置相连接

- Die Modelle dürfen nur an Geräte der Schutzklasse II angeschlossen werden, die mit dem entsprechenden Symbol gekennzeichnet sind.
- Ensure that the models are connected only to equipment rated in protection category II and marked with the appropriate symbol.
- Le raccordement des maquettes est uniquement permis à des appareils dotés de la catégorie de protection II qui portent le pictogramme respectif.
- De modellen mogen alleen op apparaten uit beschermingsklasse II worden aangesloten, die zijn voorzien van het bijbehorende symbool.
- Los modelos sólo pueden ser conectados a aparatos de clase de protección II que están identificados con el símbolo correspondiente.
- Os modelos somente devem ser conectados nos aparelhos da classe de proteção II, que são identificados com o símbolo correspondente.
- I modelli devono essere collegati solo ad apparecchi della classe di protezione II, contrassegnati con il relativo simbolo.
- Модели можно подключать только к приборам класса защиты II, обозначенным соответствующим знаком.
- 这些模型只允许连接到具有防护等级 II 的装置上，这类装置被用相应的符号进行了标识。

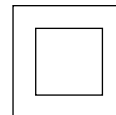

- Das Spielzeug darf nur mit einer der folgenden Fischertechnik Energiequellen benutzt werden: Transformator für Spielzeuge (Power Set) oder Accu Pack 8,4V Art.-Nr. 35537. Der Transformator ist kein Spielzeug!
- The toy may only be used with one of the following Fischertechnik energy sources: Transformer for toys (Power Set) or Accu Pack 8.4V Art No. 35537. The transformer is not a toy!
- L'utilisation de ce jouet n'est permise qu'avec l'une des sources d'énergie Fischertechnik suivantes: transformateur pour jouets Power Set ou Art. n° : 35537 pack d'accumulateurs 8,4 volts. Le transformateur n'est pas un jouet !
- Het speelgoed mag uitsluitend met een van de volgende Fischertechnik energiebronnen worden gebruikt: transformator voor speelgoed art.nr.: Power Set of art.nr.: 35537 accupack 8,4V. De transformator is geen speelgoed!
- El juguete se debe utilizar únicamente con una de las siguientes fuentes de energía: Transformador para juguetes Power Set o Art. No. 35537 paquete acumulador de 8,4V. ¡El transformador no es un juguete!
- O brinquedo somente pode ser utilizado com uma das seguintes fontes de energia da Fischertechnik: transformador para brinquedos Power Set ou art. nº: 35537 Bloco de bateria de 8,4V. O transformador não é um brinquedo!
- Questo giocattolo può essere utilizzato solo con le seguenti fonti di energia Fischertechnik: trasformatore per giocattoli Power Set oppure cod. prod.: 35537 confezione batterie da 8,4V. Il trasformatore non è un giocattolo!
- Игрушку можно использовать только с одним из следующих источников энергии от Fischertechnik: Трансформатор Power Set для игрушек или арт. №: 35537 Accu Pack 8,4V . Трансформатор не является игрушкой!
- 该玩具只允许使用如下的慧鱼 (Fischertechnik) 能量源：玩具的变压器 (Power Set)，或者商品号：35537，8.4V 电池套件 (Accu Pack)。变压器不是玩具！

- Achtung! Verletzungsgefahr an Bauteilen mit funktionsbedingten scharfen Kanten und Spitzen!
- Caution! Be careful not to hurt yourself on components with sharp or pointed edges!
- Attention! Risque de blessure sur les éléments comportant des arêtes et o pointes vives indispensables au bon fonctionnement!
- Let op! U kunt zich bezeren aan bouwstenen met scherpe randen of punten!
- Attenzione! Esiste il pericolo di lesione con i pezzi di costruzione che hanno bordi e punte spigolosi necessari per la funzionalità del pezzo!
- Atenção! Perigo de ferimentos em peças componentes com cantos vivos e pontas obrigatórios para o funcionamento !
- Attenzione! Pericolo di lesioni dovute a componenti con spigoli vivi e punte per motivi funzionali!
- Будьте осторожны! Об острые края деталей и и наконечники можно порезаться!
- 注意！因功能需要而带有锋利的棱边和尖角的部件可能会带来受伤危险！

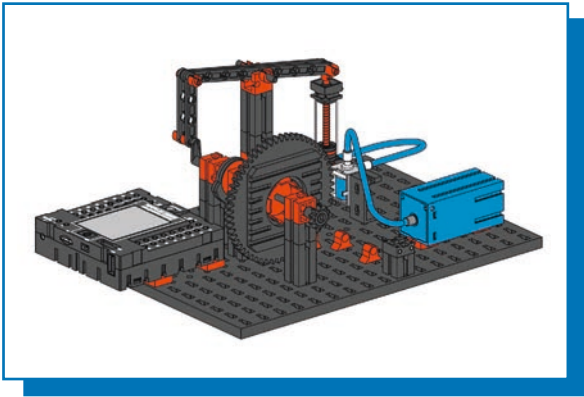

Druckluftmotor
Compressed air motor
Moteur pneumatique

Persluchtmotor
Motor de aire comprimido
Motor de ar comprimido

Motore ad aria compressa
ПНЕВМОМОТОР
压缩空气马达

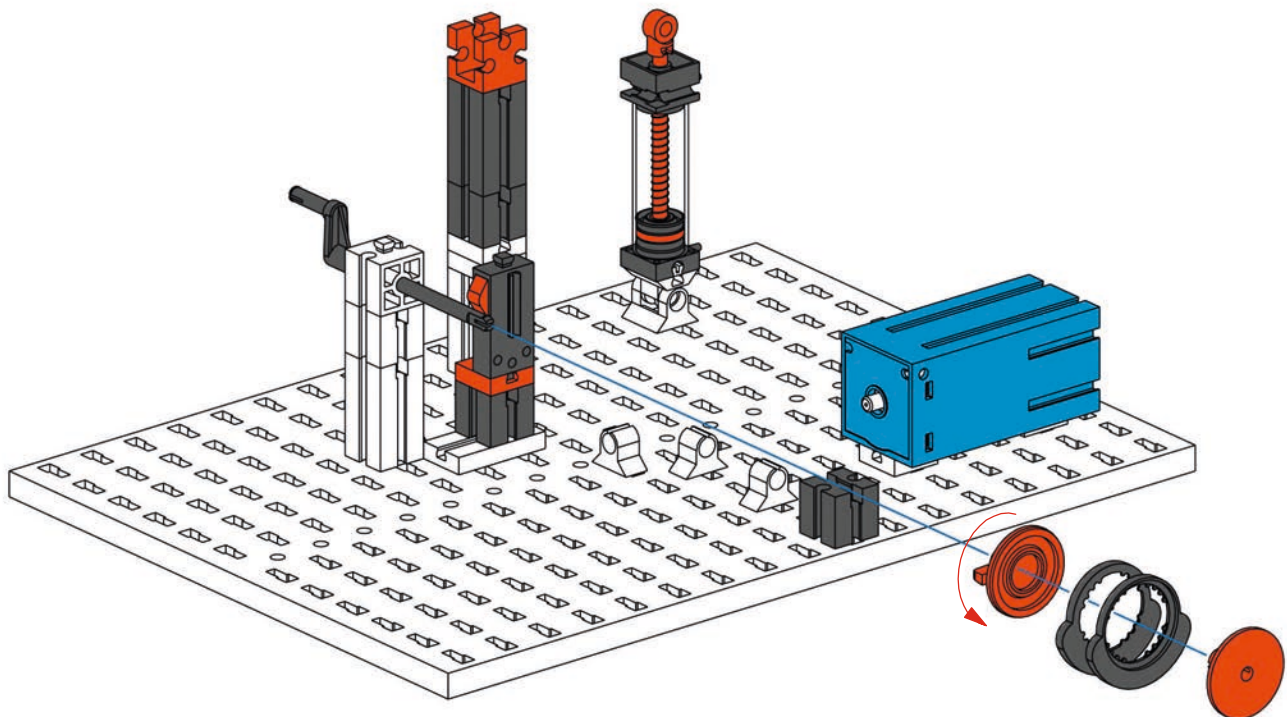
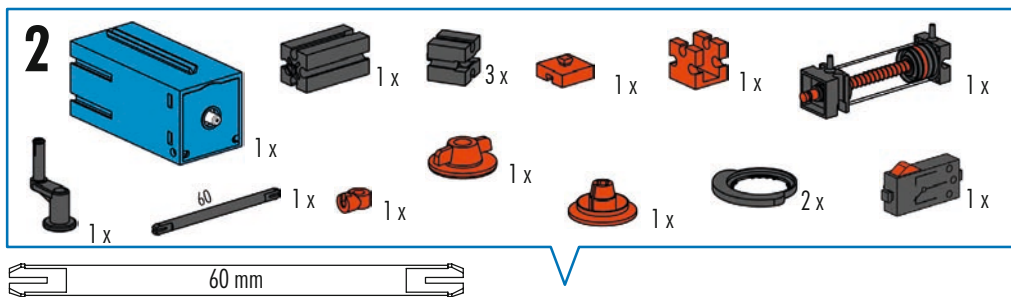
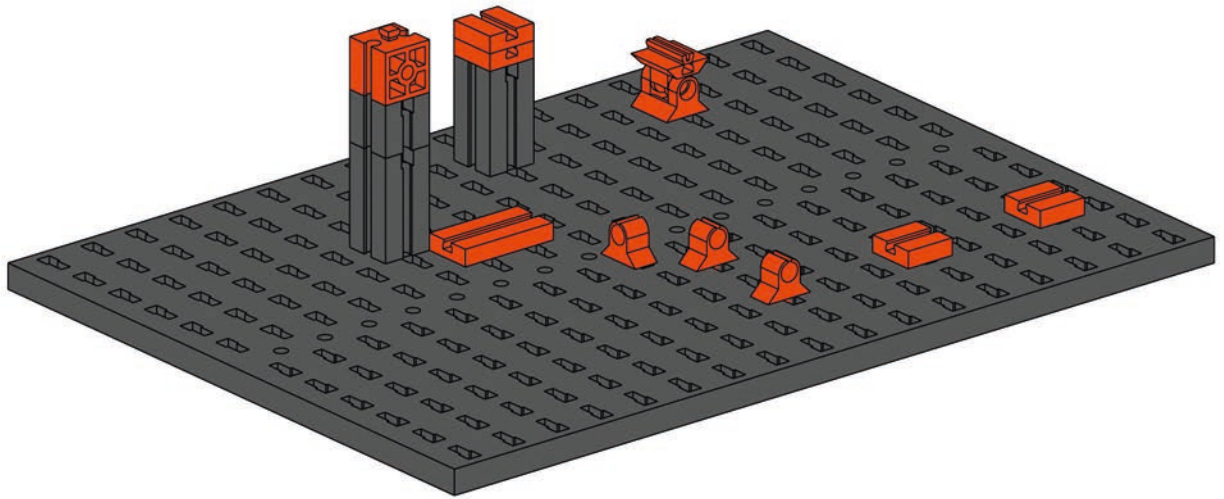
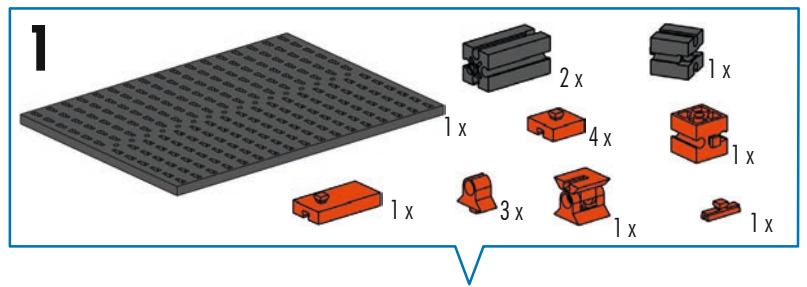

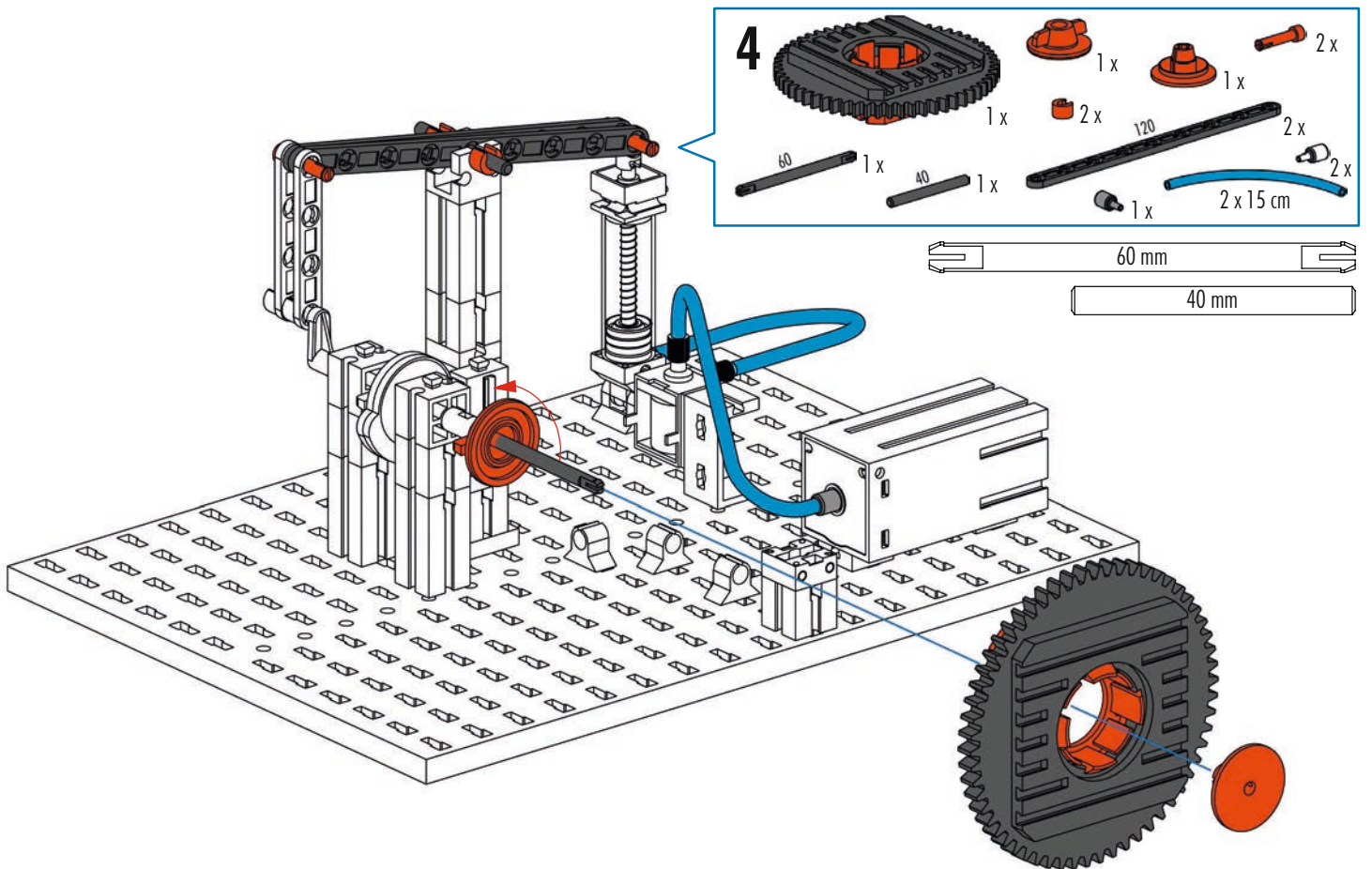
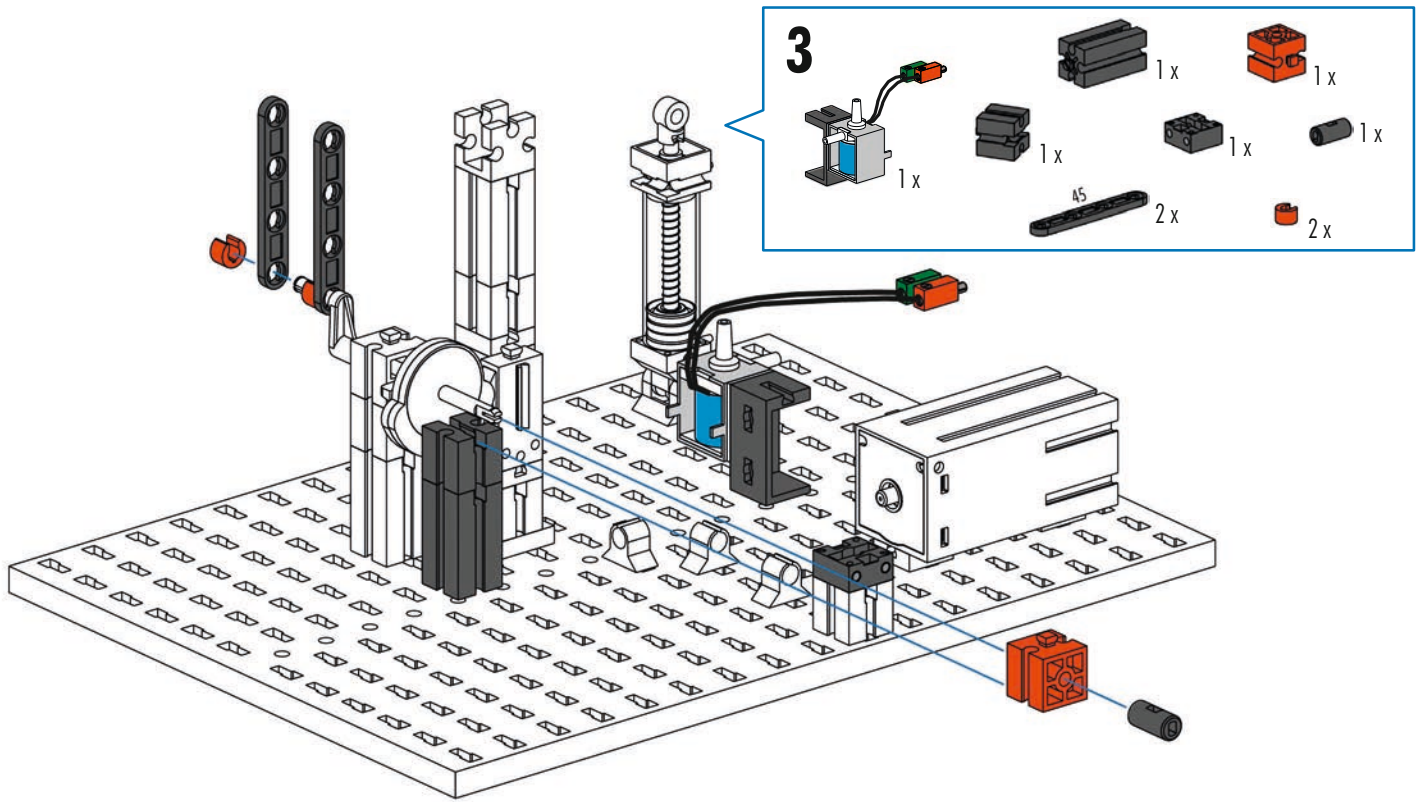

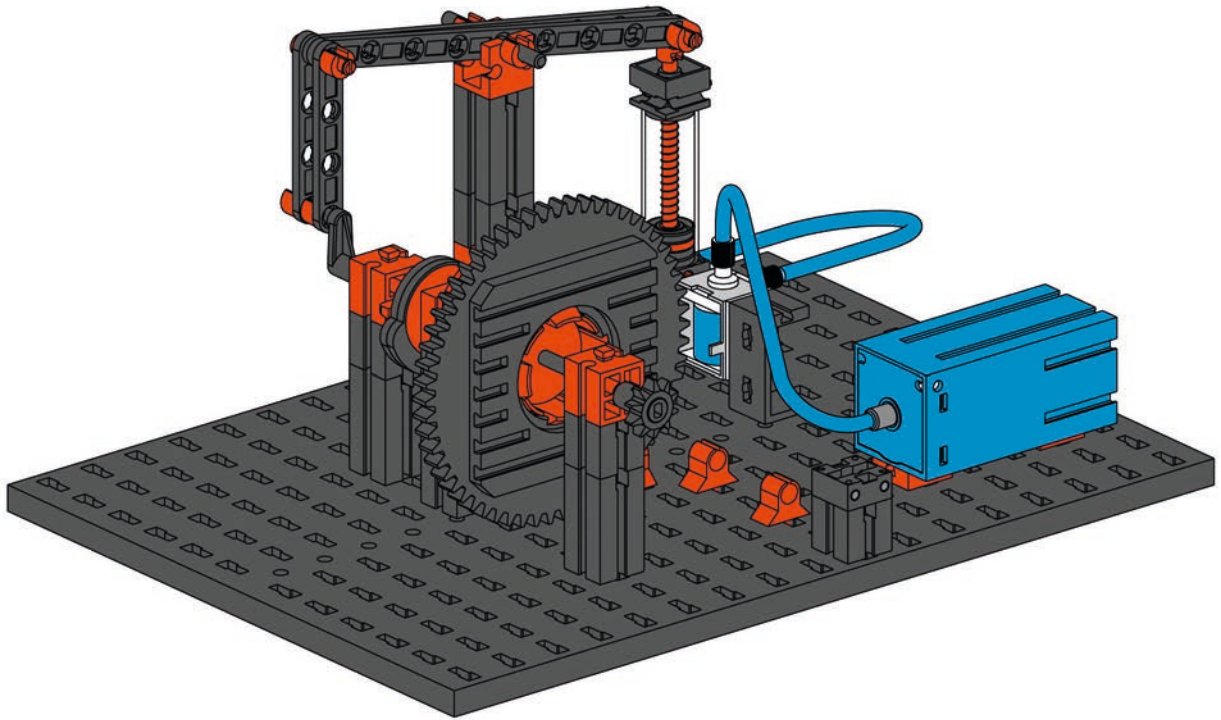
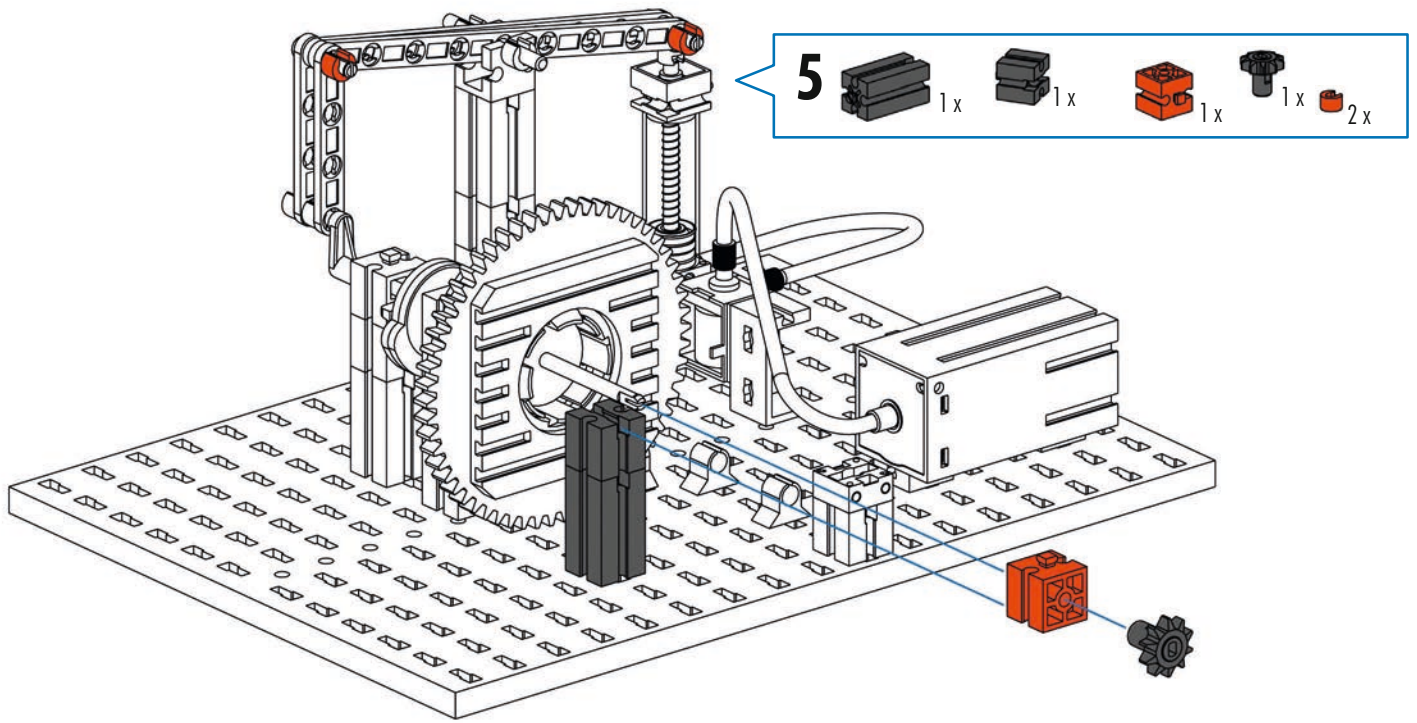

Schaltplan A
Circuit diagram A
Plan électrique A

Schakelschema A
Diagrama de circuitos A
Plano elétrico de ligação A

Schema elettrico A
Схема подключения A
电路图 A

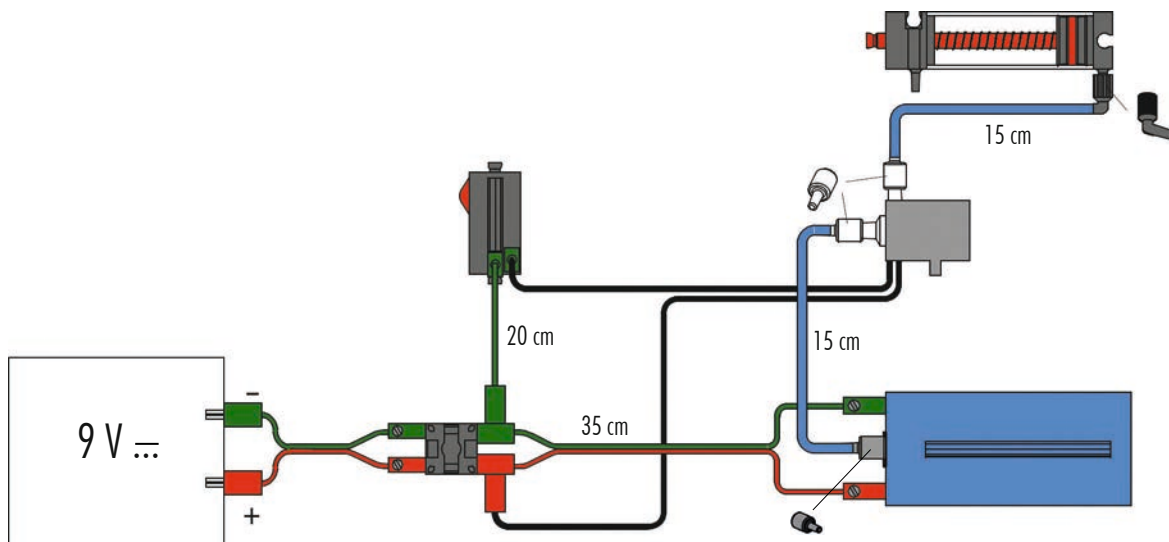

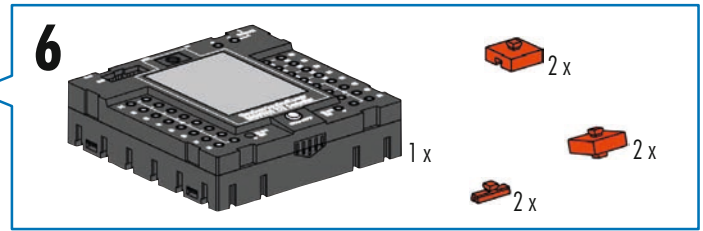
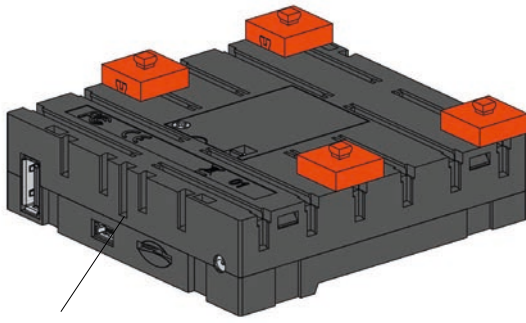

- ROBO TXT Controller (Art.-Nr. 522429) nicht im Baukasten enthalten
- ROBO TXT Controller (Art.-Nr. 522429) not included in the modular kit
- ROBO TXT Controller (Art.-Nr. 522429) n'est pas contenue dans le kit
- ROBO TXT Controller (Art.-Nr. 522429) niet in de bouwdoos opgenomen
- ROBO TXT Controller (Art.-Nr. 522429) no está incluido en el conjunto
- ROBO TXT Controller (Art.-Nr. 522429) não contido no sistema de construção por blocos
- ROBO TXT Controller (Art.-Nr. 522429) non incluso nella scatola di montaggio
- ROBO TXT Controller (Art.-Nr. 522429) не входит в комплект конструктора
- ROBO TXT Controller (Art.-Nr. 522429) 不包含在组件

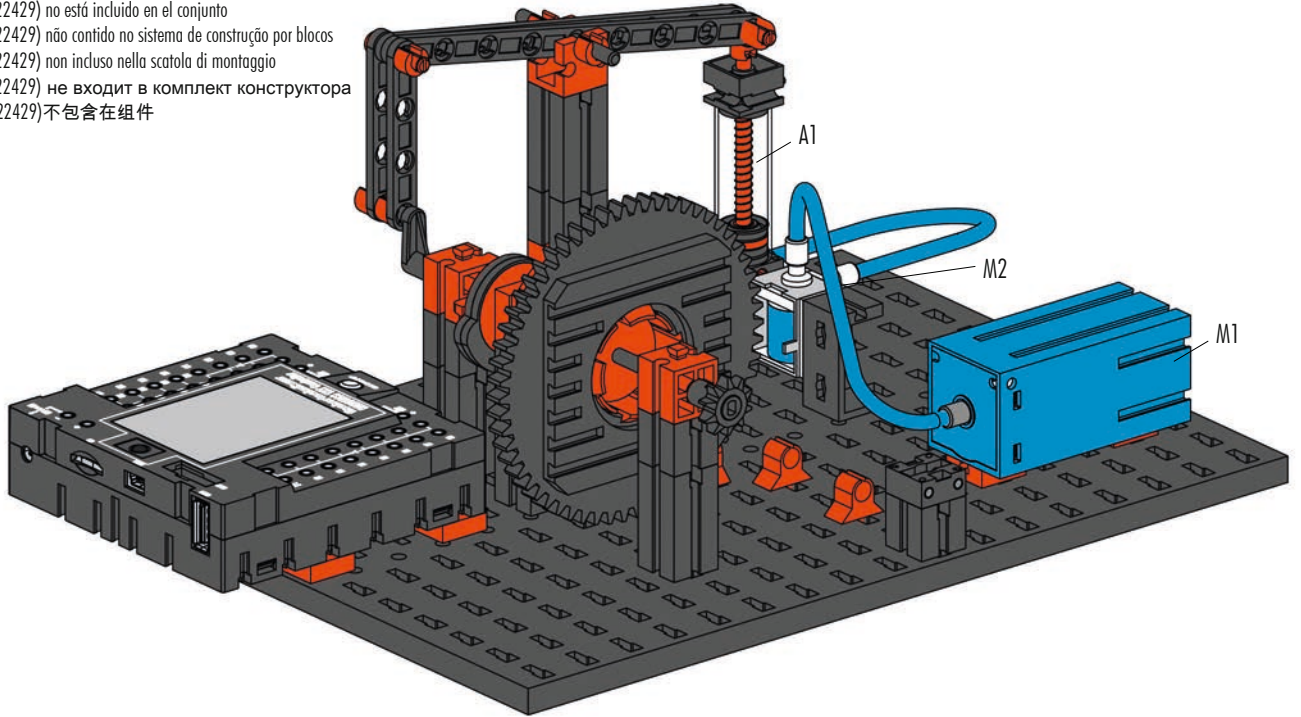

Schaltplan B
Circuit diagram B
Plan électrique B

Schakelschema B
Diagrama de circuitos B
Plano elétrico de ligação B

Schema elettrico B
Схема подключения B
电路图 B

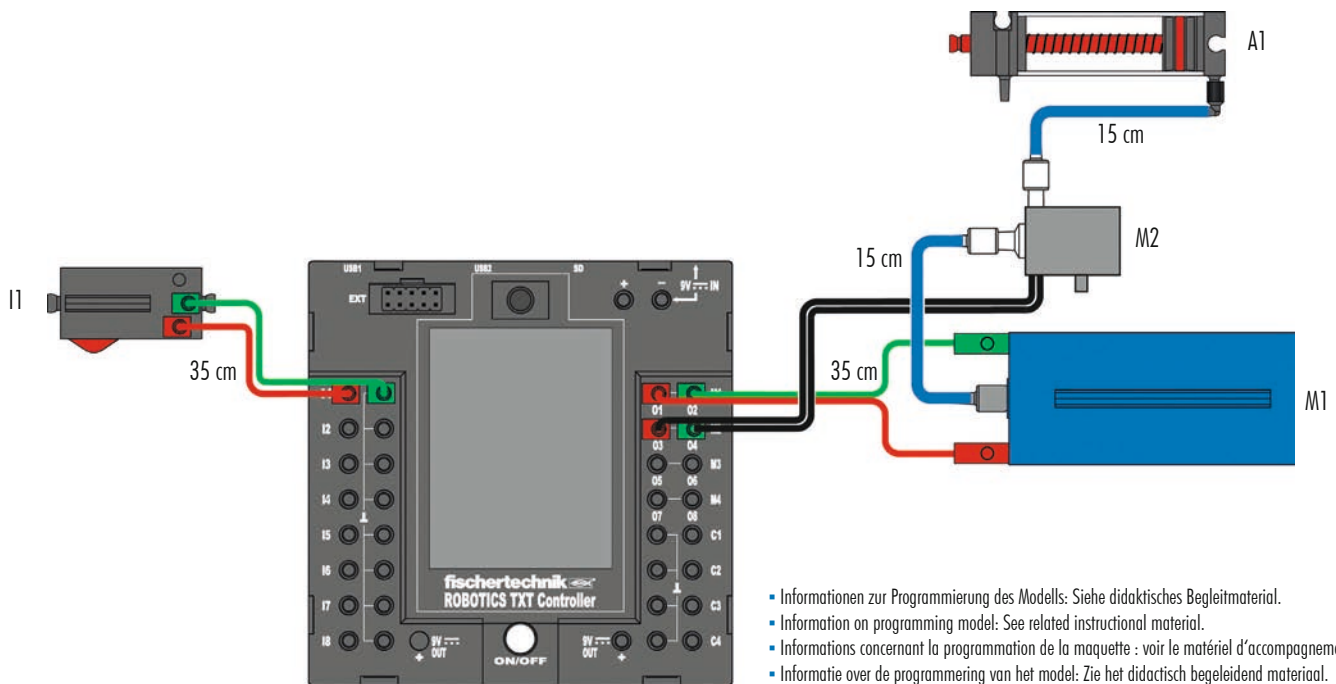

- Informationen zur Programmierung des Modells: Siehe didaktisches Begleitmaterial.
- Information on programming model: See related instructional material.
- Informations concernant la programmation de la maquette : voir le matériel d'accompagnement didactique.
- Informatie over de programmering van het model: Zie het didactisch begeleidend materiaal.
- Informaciones sobre la programación del modelo: Véase material didáctico.
- Informações sobre a programação do modelo: ver o material didático de acompanhamento.
- Informazioni sulla programmazione del modello: vedi materiale didattico.
- Информация о программировании модели: смотрите обучающий сопроводительный материал.
- 有关该模型编程的信息：见指导性说明资料。

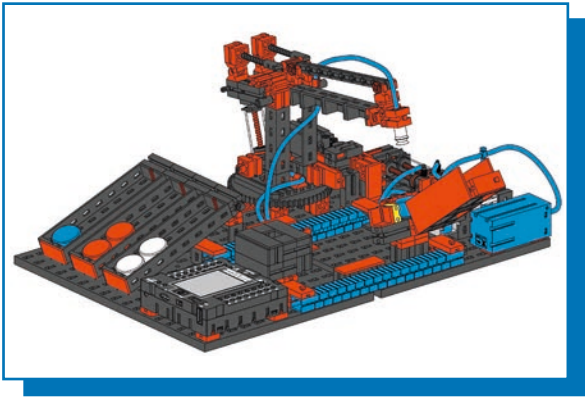

Farbsortierroboter
Color sorting robot
Robot de triage des couleurs

Kleurensorteerrobot
Robot clasificador por colores
Robo seleccionador de cores

Robot assortitore di colori
Робот-цветосортировщик
辨色分选机器人

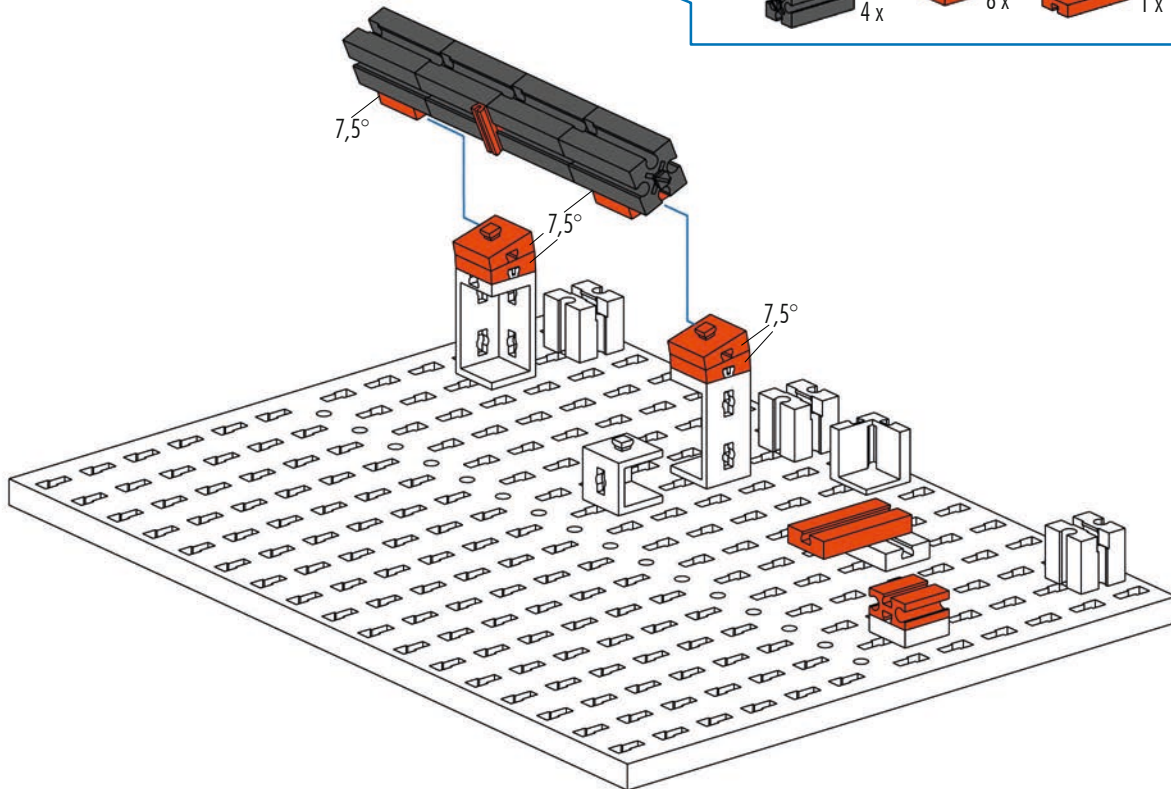
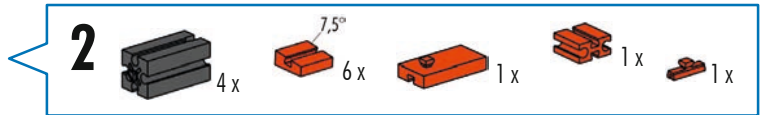
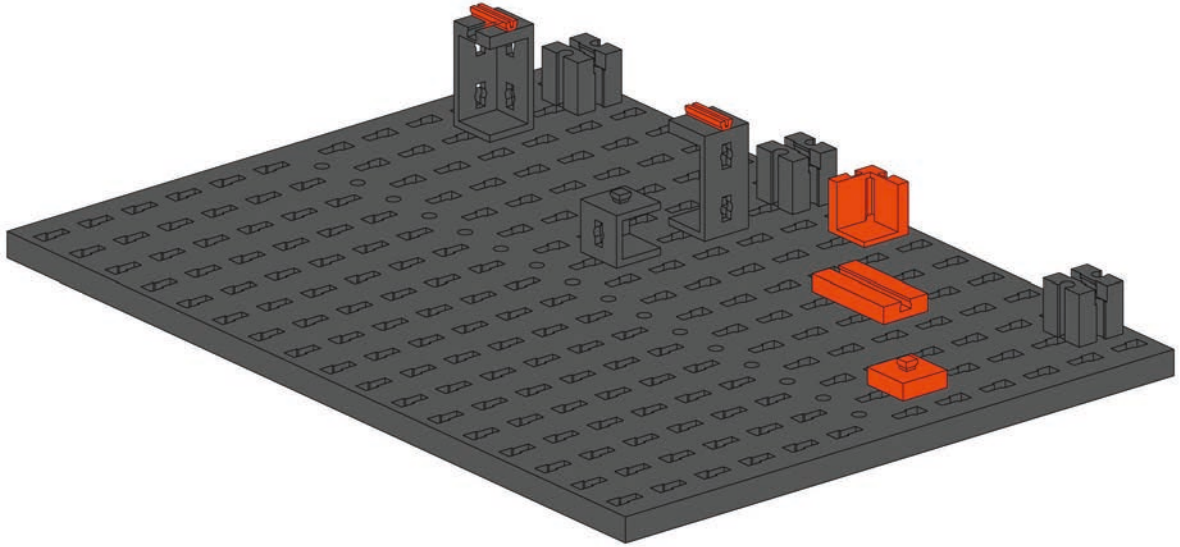
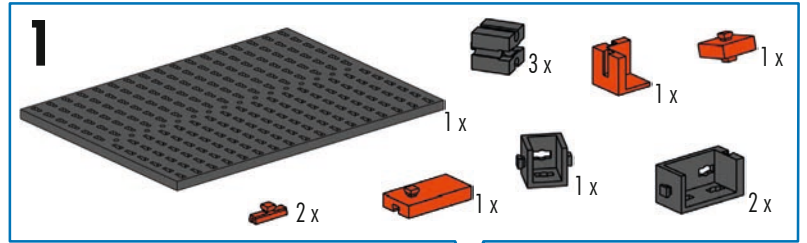

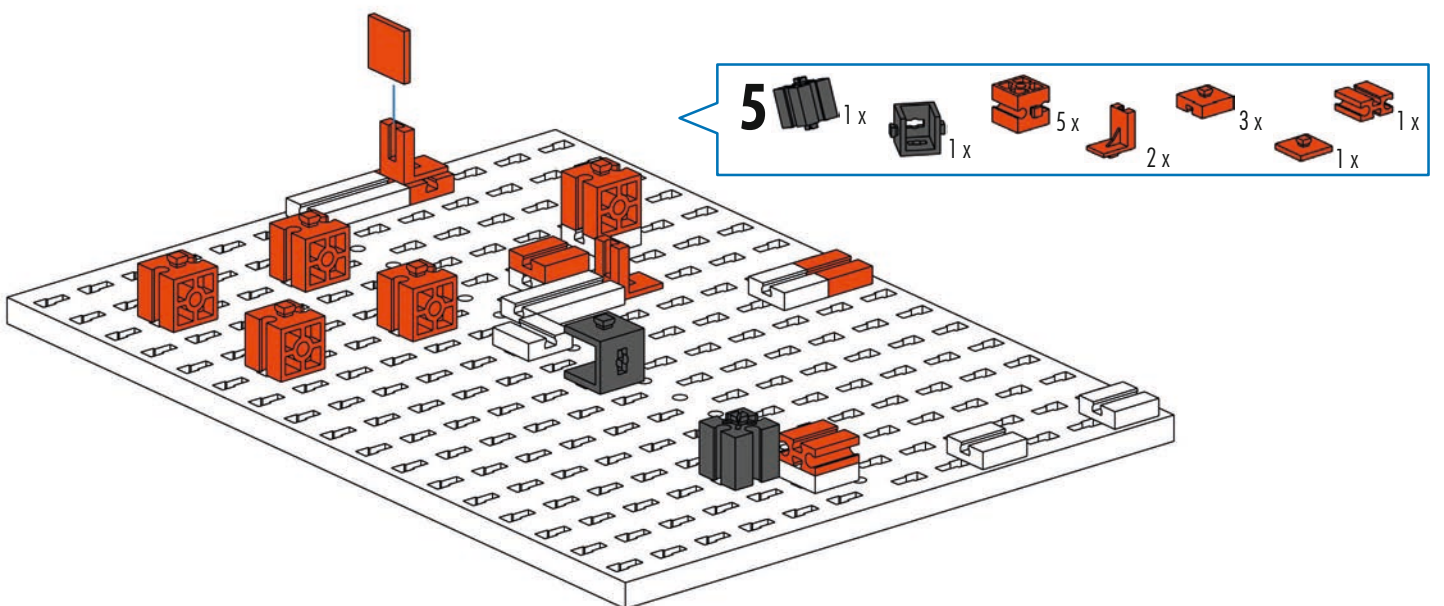
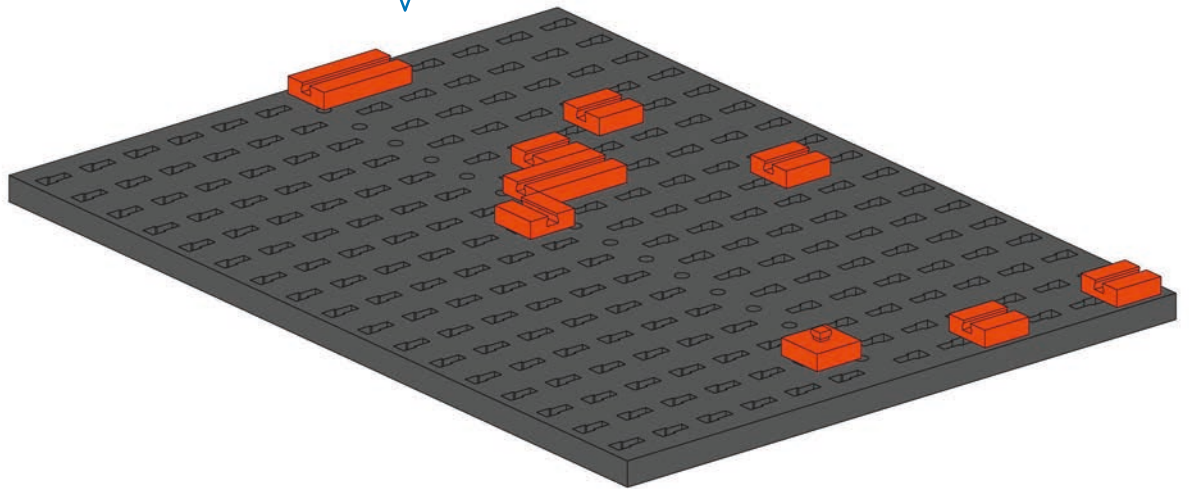
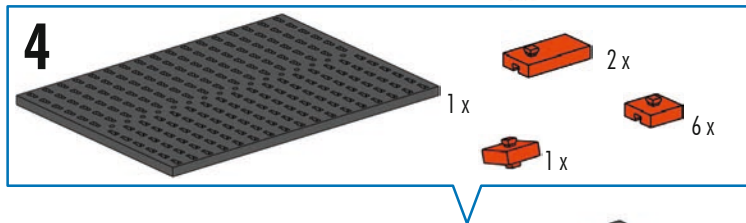
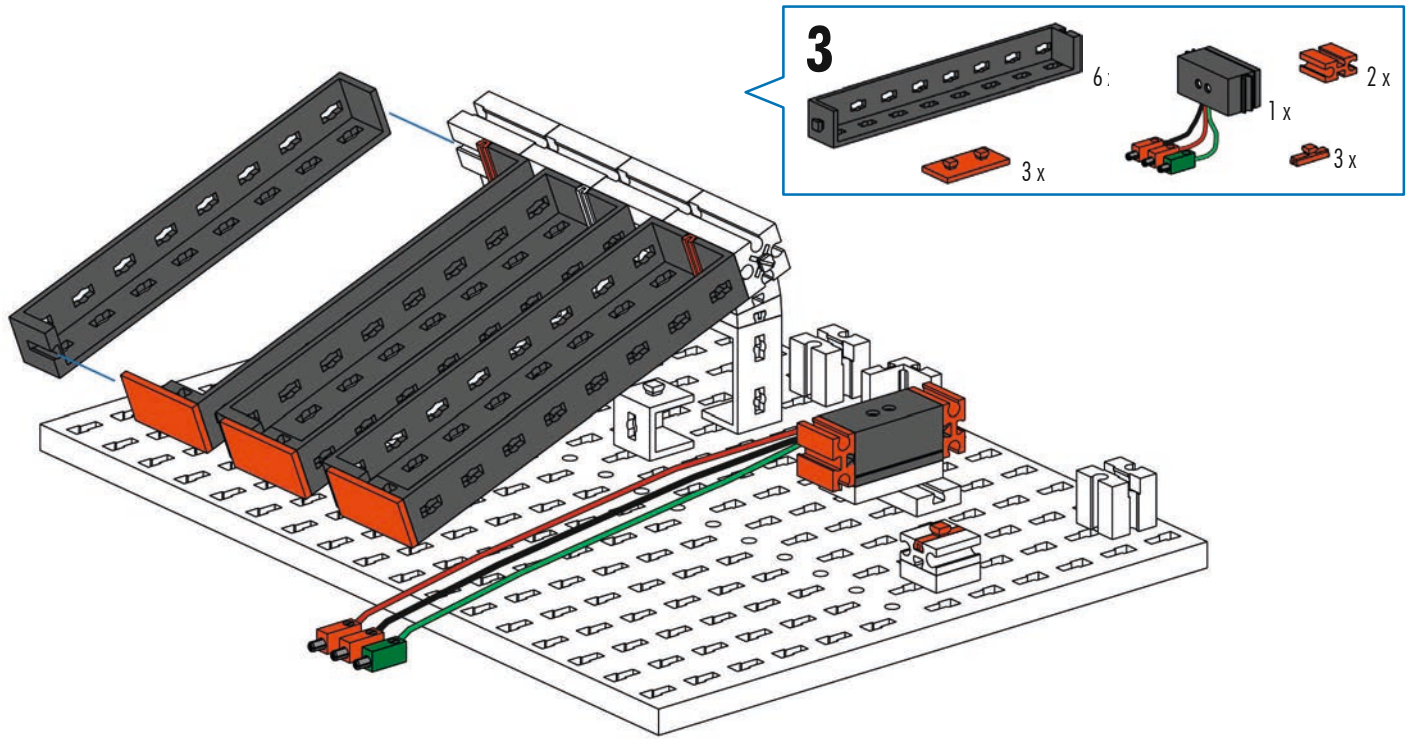

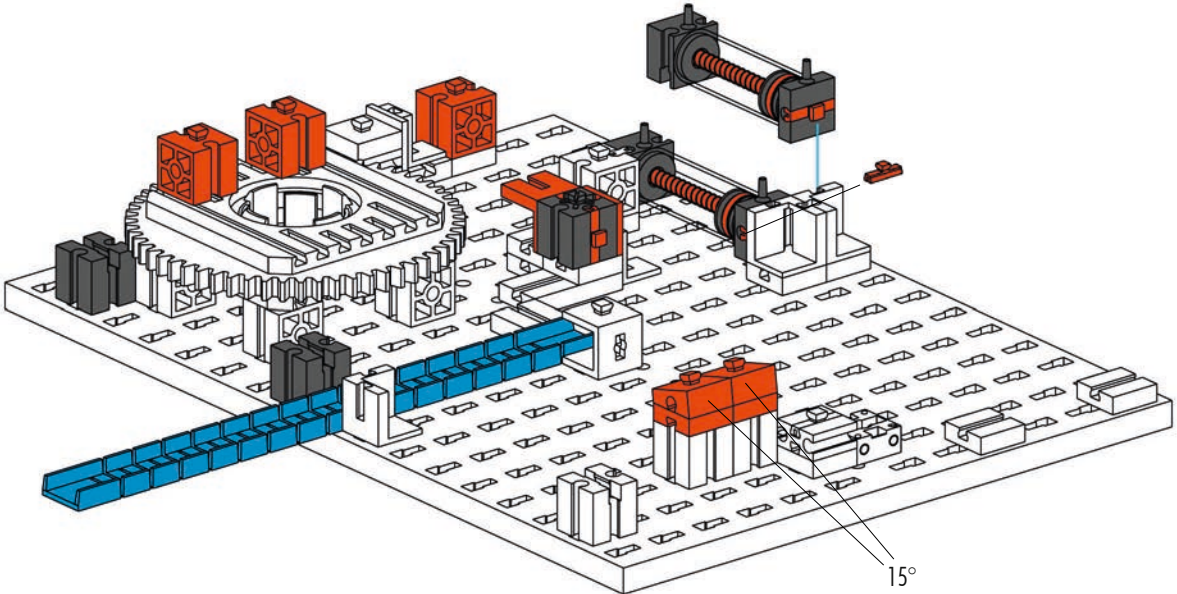
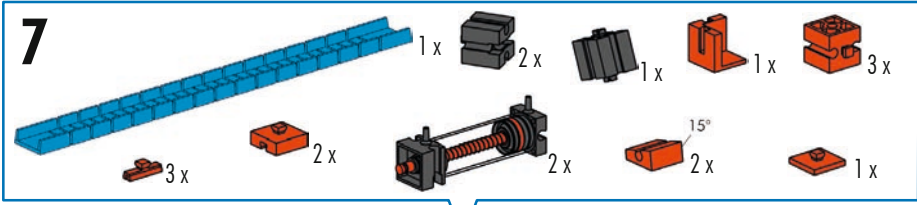
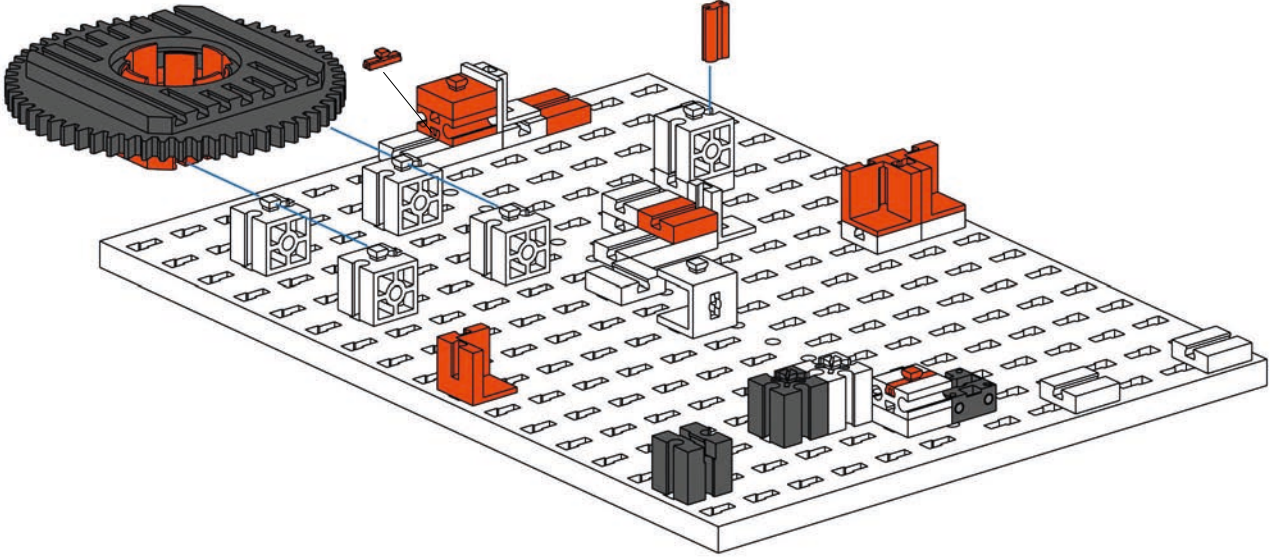
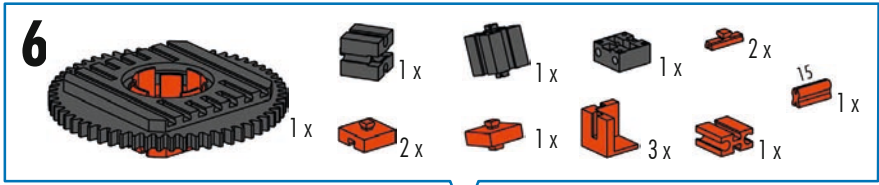

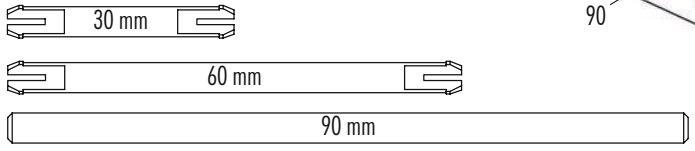
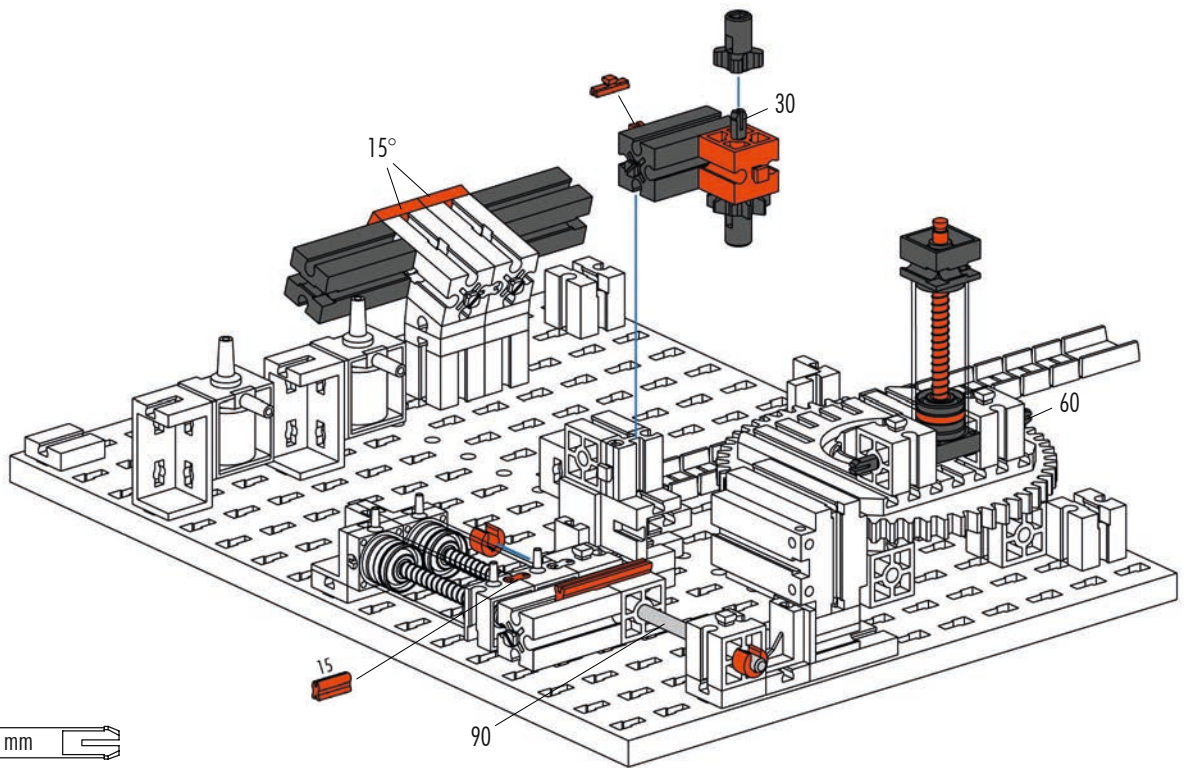
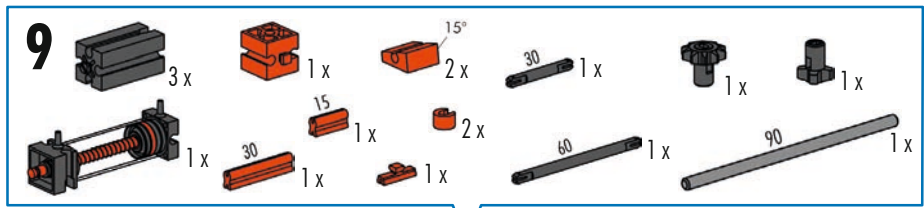
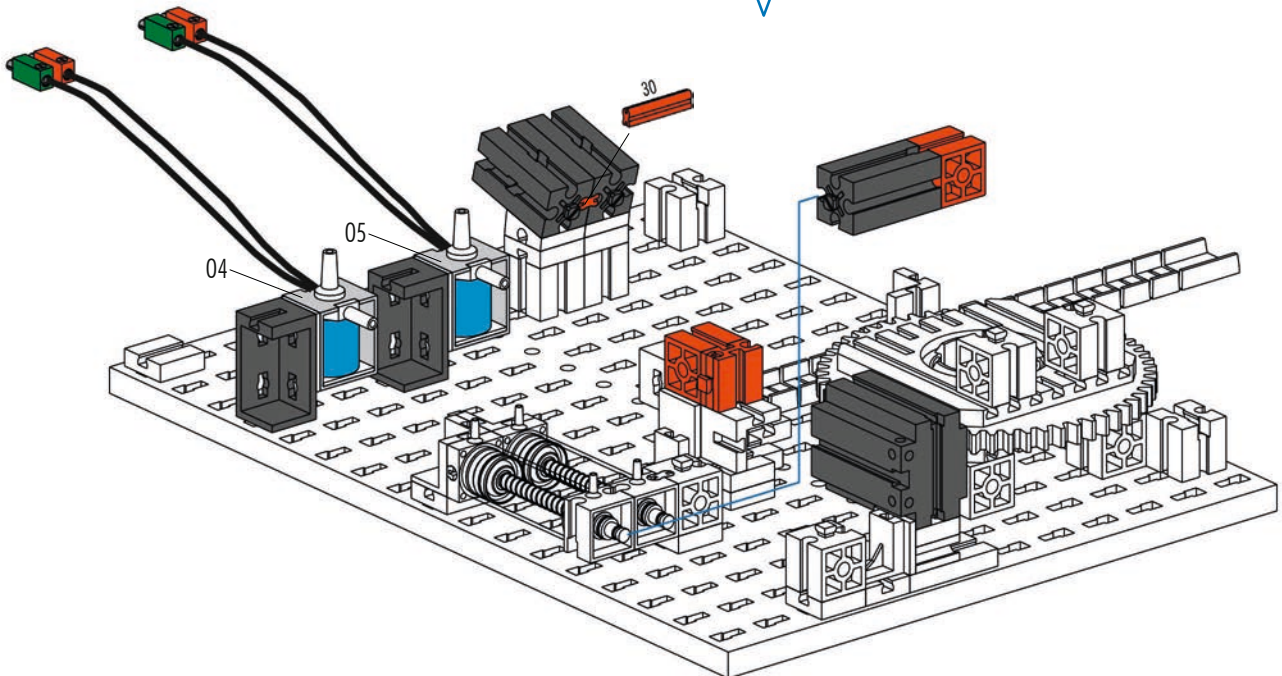
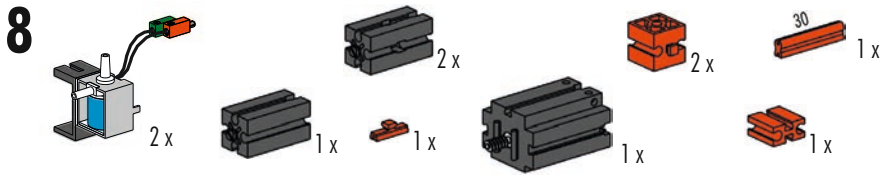

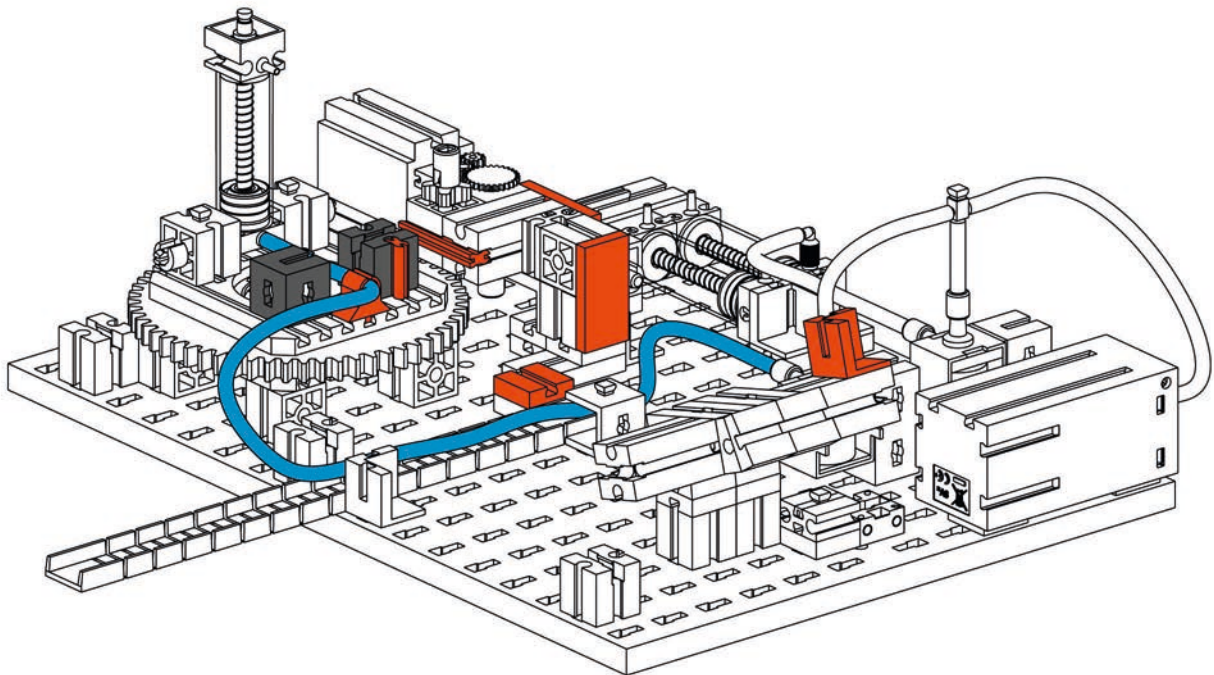
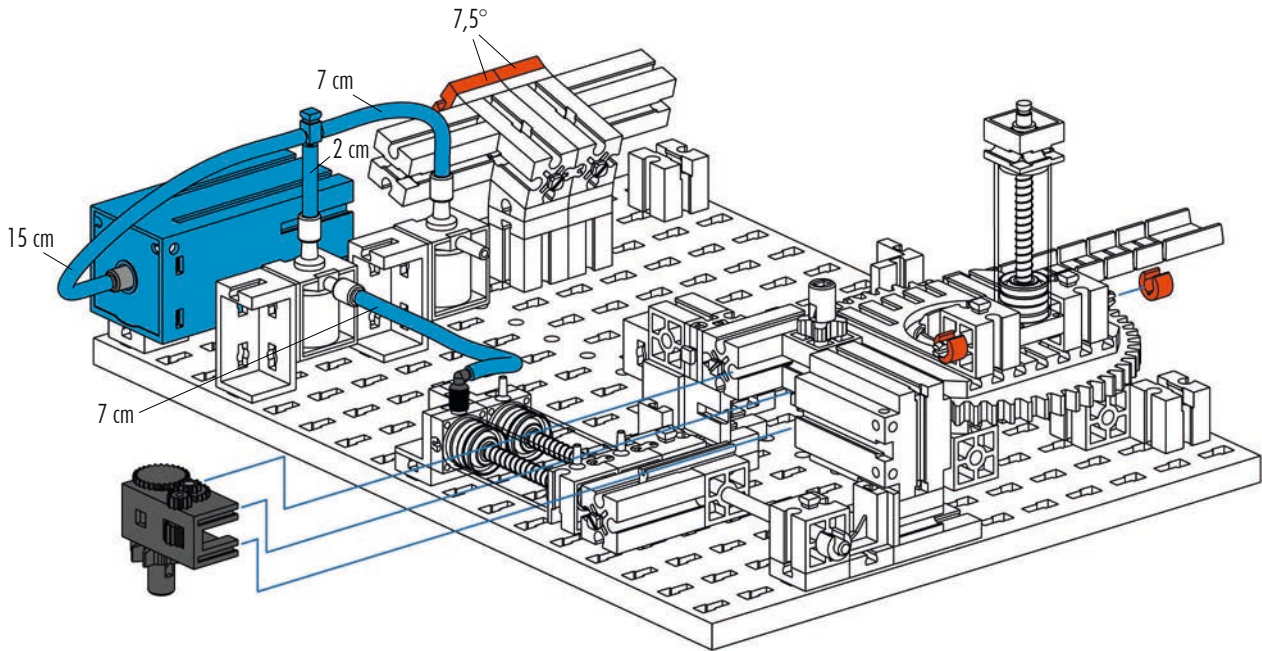
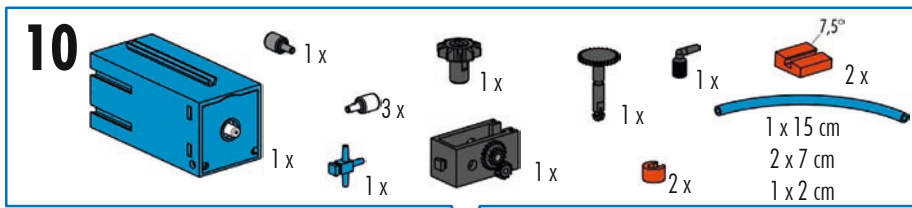

12

- 2x (Grey Technic Beam 1x5)
- 2x (Red Technic Connector)
- 2x (Red Technic Beam 1x3)
- 1x (Red Technic Pin)
- 1x (Red Technic Connector)
- 1x (Red Technic Pin)
- 2x (Grey Technic Connector)
- 1x (Grey Technic Pin with Label 'L')

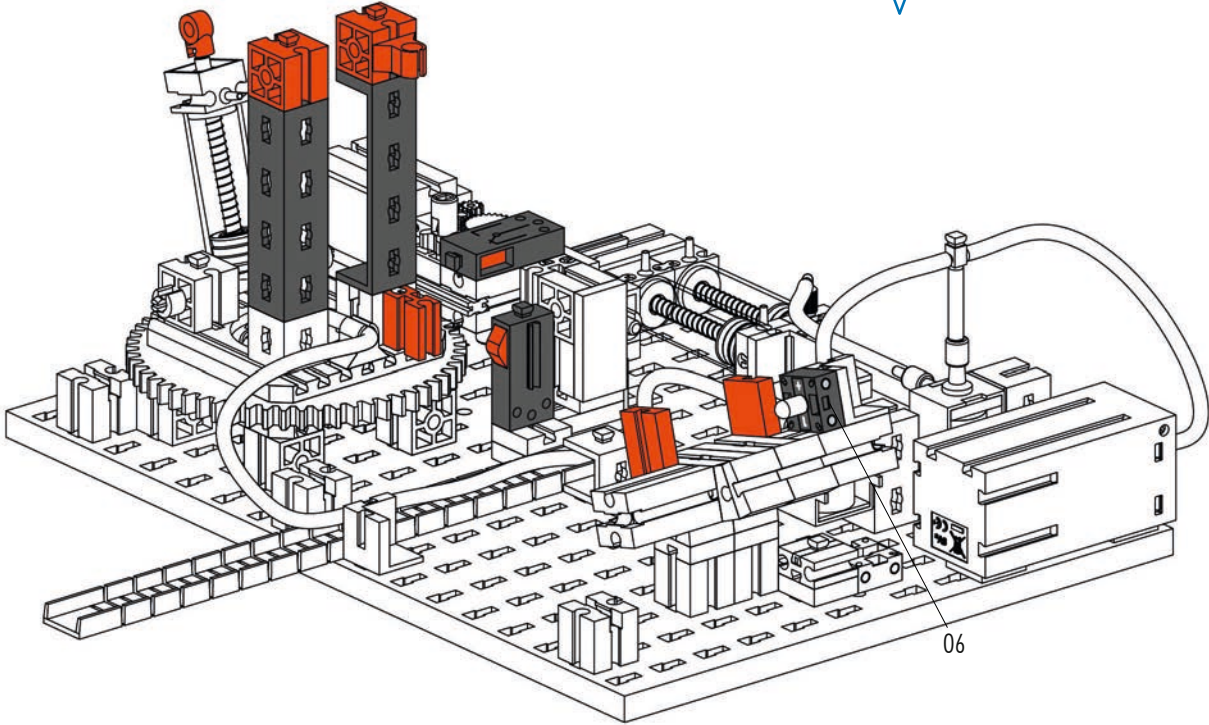

13

- 2x (Grey Technic Beam 1x5)
- 1x (Grey Technic Connector)
- 1x (Grey Technic Pin)
- 1x (Red Technic Connector)
- 1x (Red Technic Beam 1x3)
- 1x (Red Technic Connector)
- 1x (Red Technic Pin with Label '7,5°')
- 1x (Red Technic Pin with Label '15')
- 1x (Red Technic Pin)
- 2x (Red Technic Pin with Label '4')
- 3x (Grey Technic Connector)
- 1x (Grey Technic Connector)
- 1x (Grey Technic Beam 1x60)

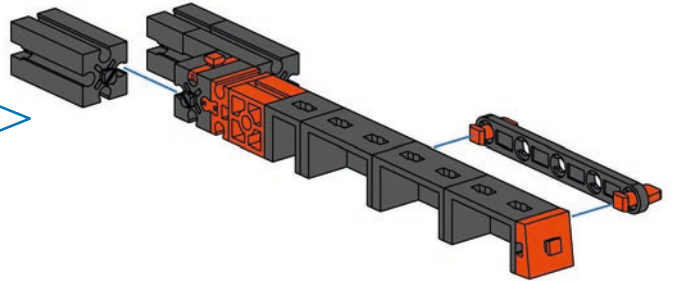

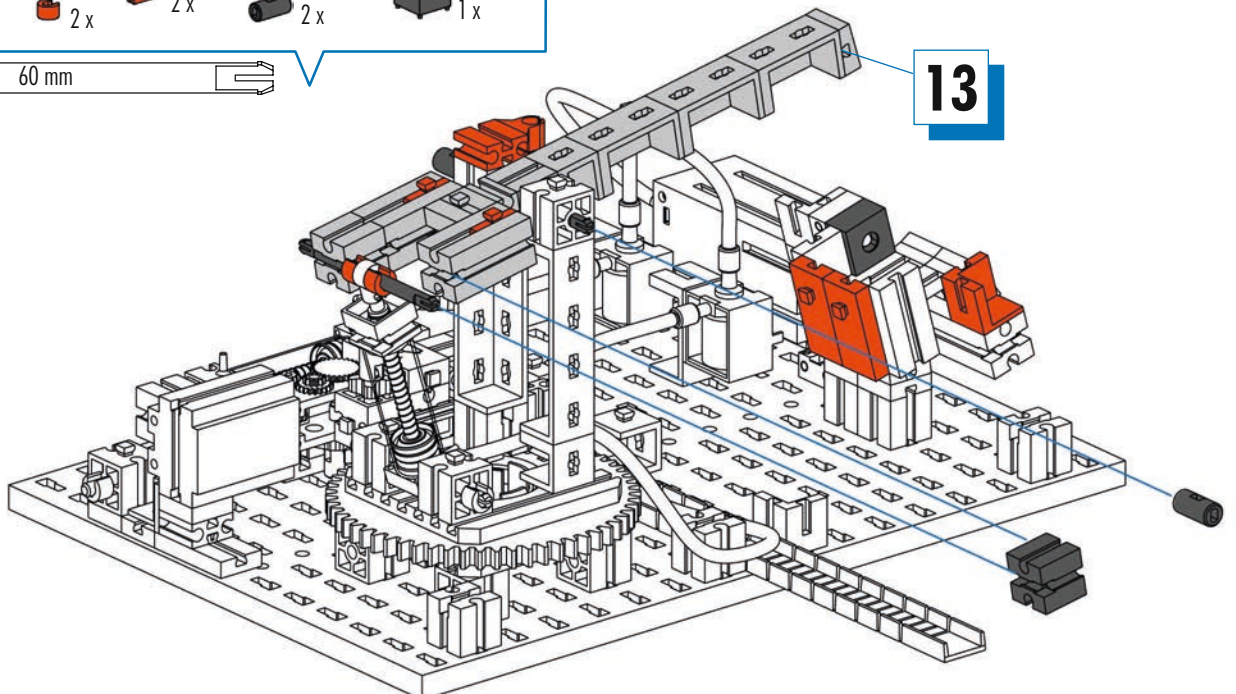
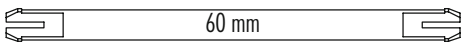

14

- 1x (Grey Technic Connector)
- 1x (Red Technic Connector)
- 1x (Red Technic Connector)
- 2x (Red Technic Beam 1x3)
- 1x (Red Technic Pin)
- 2x (Grey Technic Beam 1x60)
- 2x (Red Technic Pin)
- 2x (Red Technic Pin)
- 2x (Grey Technic Pin)
- 1x (Grey Technic Connector)





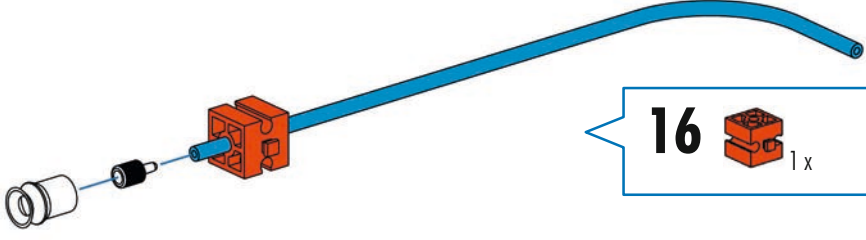
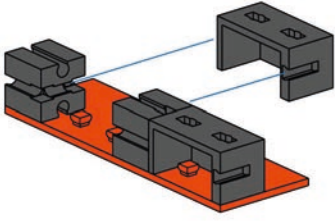

15







1x  2x  2x 

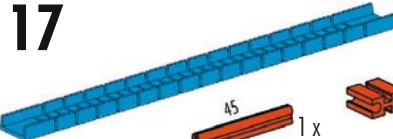

16

1x  1x  1x  1x  1 x 50 cm

17

1x  3x  1x  1x  1x  4x 1x  1x 3x 

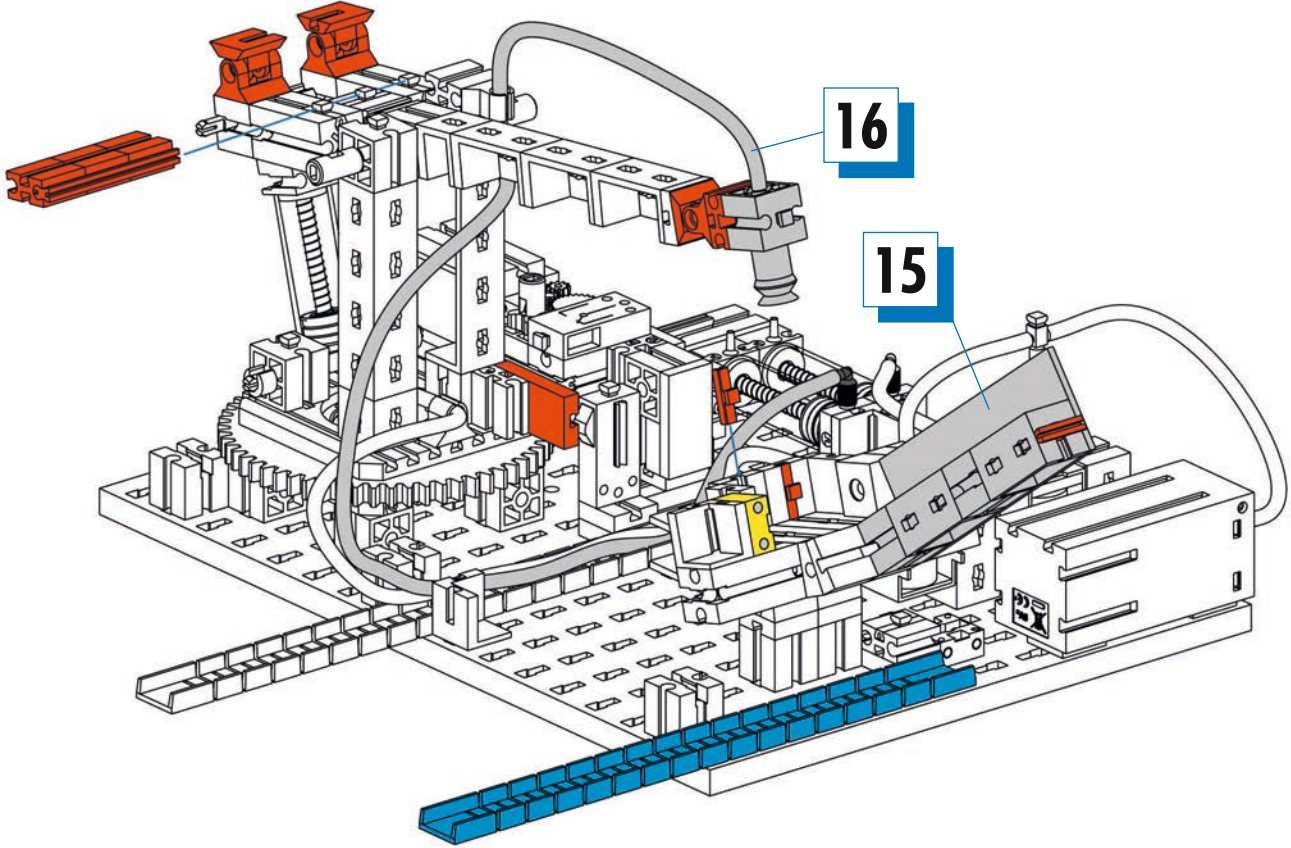

18

- 1 x (orange 1x5 Technic plate)
- 2 x (grey 1x2 Technic pin)
- 2 x (grey 1x2 Technic bush)
- 1 x (orange 1x2 Technic pin)

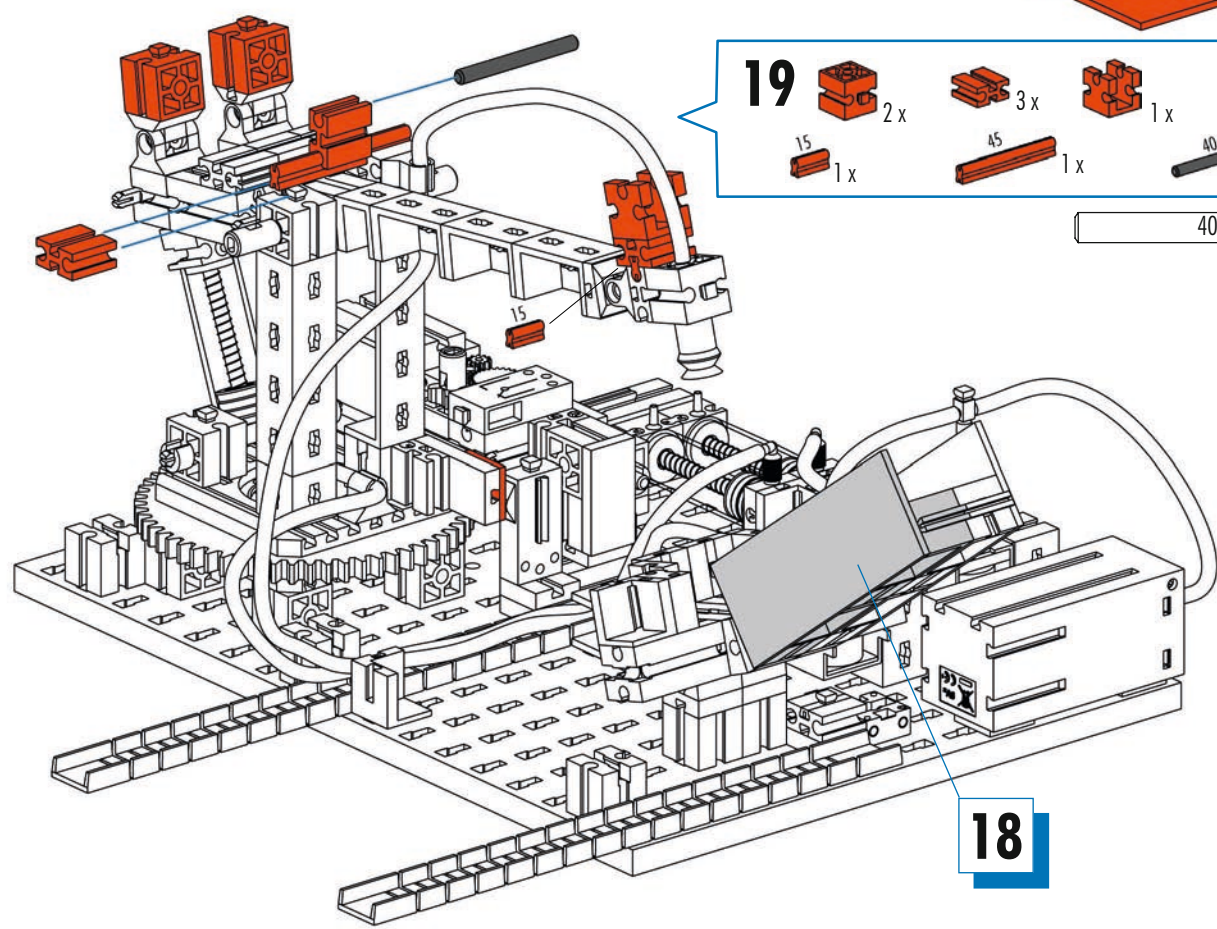
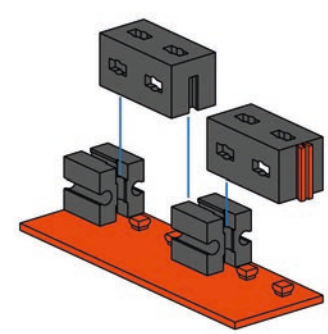

19

- 2 x (orange 1x2 Technic pin)
- 3 x (orange 1x2 Technic bush)
- 1 x (orange 1x2 Technic pin)
- 1 x (orange 1x2 Technic pin)
- 1 x (orange 1x2 Technic pin)
- 1 x (orange 1x2 Technic bush)
- 1 x (orange 1x2 Technic pin)
- 1 x (orange 1x2 Technic bush)

40 mm

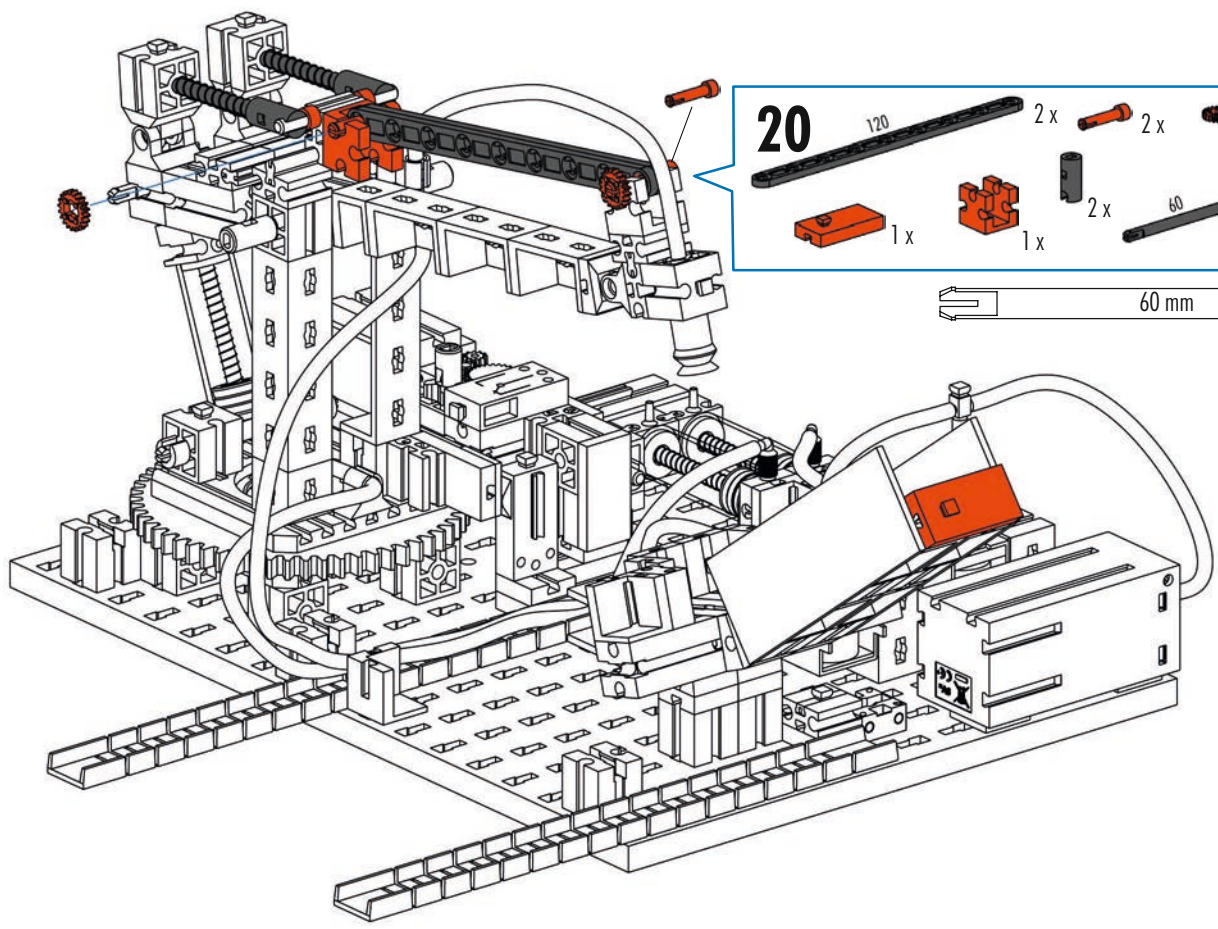



20

- 2 x (black 120 Technic axle)
- 2 x (orange 1x2 Technic pin)
- 2 x (black 1x2 Technic bush)
- 2 x (black 1x2 Technic bush)
- 2 x (orange 1x2 Technic pin)
- 1 x (orange 1x2 Technic pin)
- 1 x (orange 1x2 Technic bush)
- 2 x (black 1x2 Technic bush)
- 2 x (black 60 Technic axle)
- 2 x (black spring)

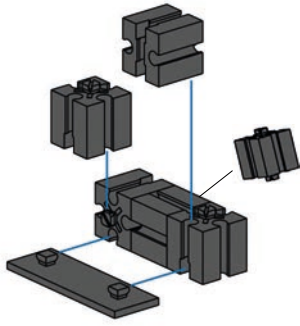



60 mm

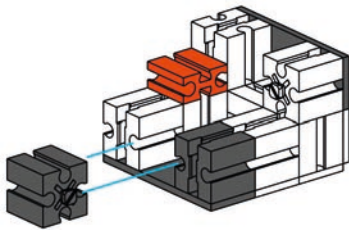
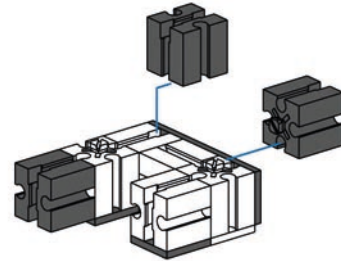

21  4x  1x  1x

22  3x  1x  2x



23  1x  1x  2x  1x

24  3x  2x

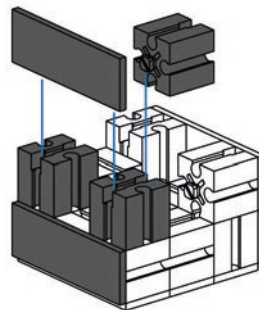

25

4 x



1 x



2 x

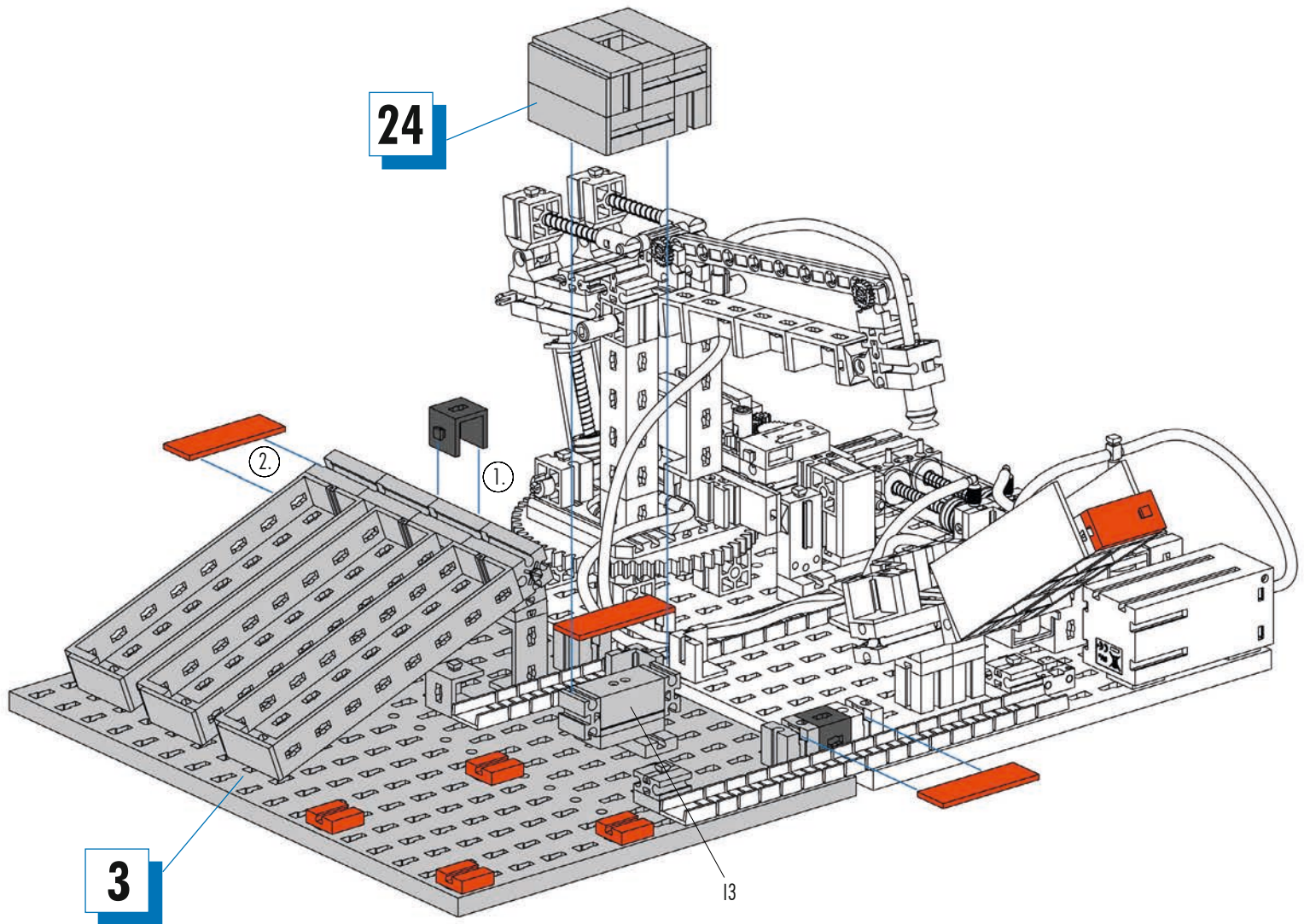

3 x

**3**

13

- ROBO TXT Controller (Art.-Nr. 522429) nicht im Baukasten enthalten
- ROBO TXT Controller (Art.-Nr. 522429) not included in the modular kit
- ROBO TXT Controller (Art.-Nr. 522429) n'est pas contenue dans le kit
- ROBO TXT Controller (Art.-Nr. 522429) niet in de bouwdoos opgenomen
- ROBO TXT Controller (Art.-Nr. 522429) no está incluido en el conjunto
- ROBO TXT Controller (Art.-Nr. 522429) não contido no sistema de construção por blocos
- ROBO TXT Controller (Art.-Nr. 522429) non incluso nella scatola di montaggio
- ROBO TXT Controller (Art.-Nr. 522429) не входит в комплект конструктора
- ROBO TXT Controller (Art.-Nr. 522429) 不包含在组件

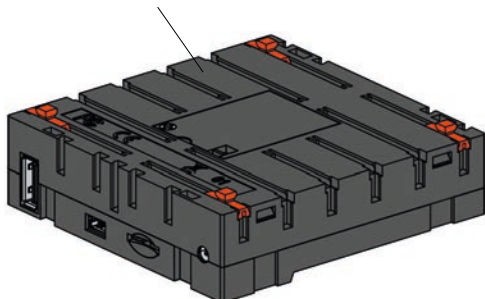
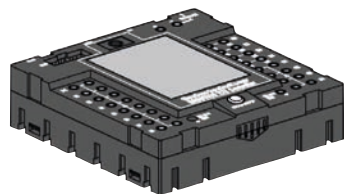
**26**

1 x

4 x

27

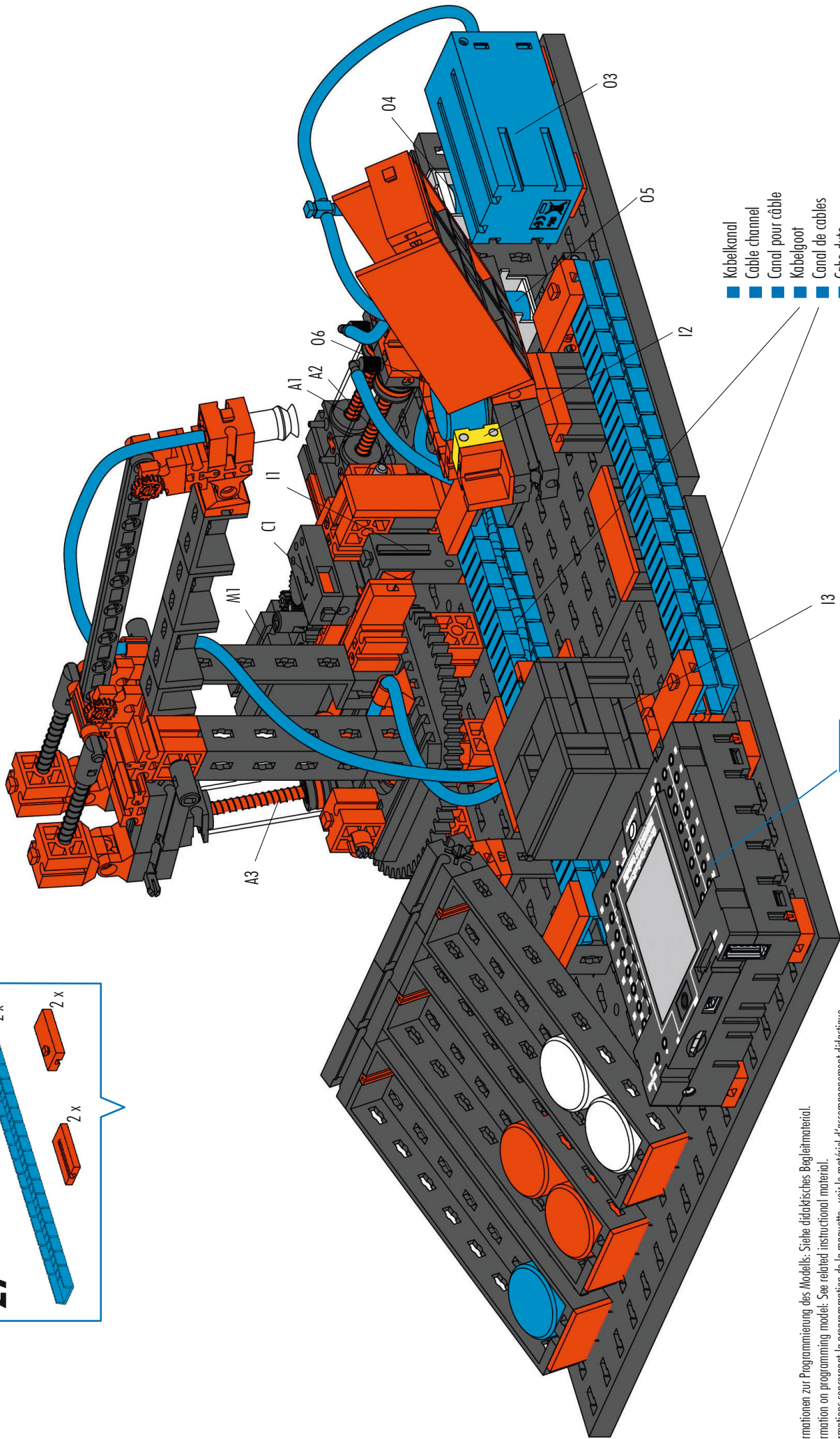
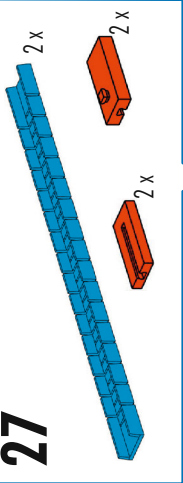

- Kabelkanal
- Cable channel
- Canal pour câble
- Kabelgoot
- Canal de cables
- Cabo duto
- Canalina per cavi
- кабельная Траншея
- 电缆管道

26

- Informationen zur Programmierung des Modells: Siehe didaktisches Begleitmaterial.
- Information on programming model: See related instructional material.
- Informations concernant la programmation de la maquette : voir le matériel d'accompagnement didactique.
- Informatie over de programmering van het model: Zie het didactisch begeleidend materiaal.
- Informaciones sobre la programación del modelo: Véase material didáctico.
- Informações sobre a programação do modelo: ver o material didático de acompanhamento.
- Informazioni sulla programmazione del modello: vedi materiale didattico.
- Информация о программировании модели: смотрите обучающий сопроводительный материал.
- 有关模型编程的信息：见指导性说明资料。

Schaltplan
Circuit diagram
Plan électrique

Schaltschema
Diagrama de circuitos
Plano eléctrico de ligação

Schema elettrico
Схема подключения
电路图

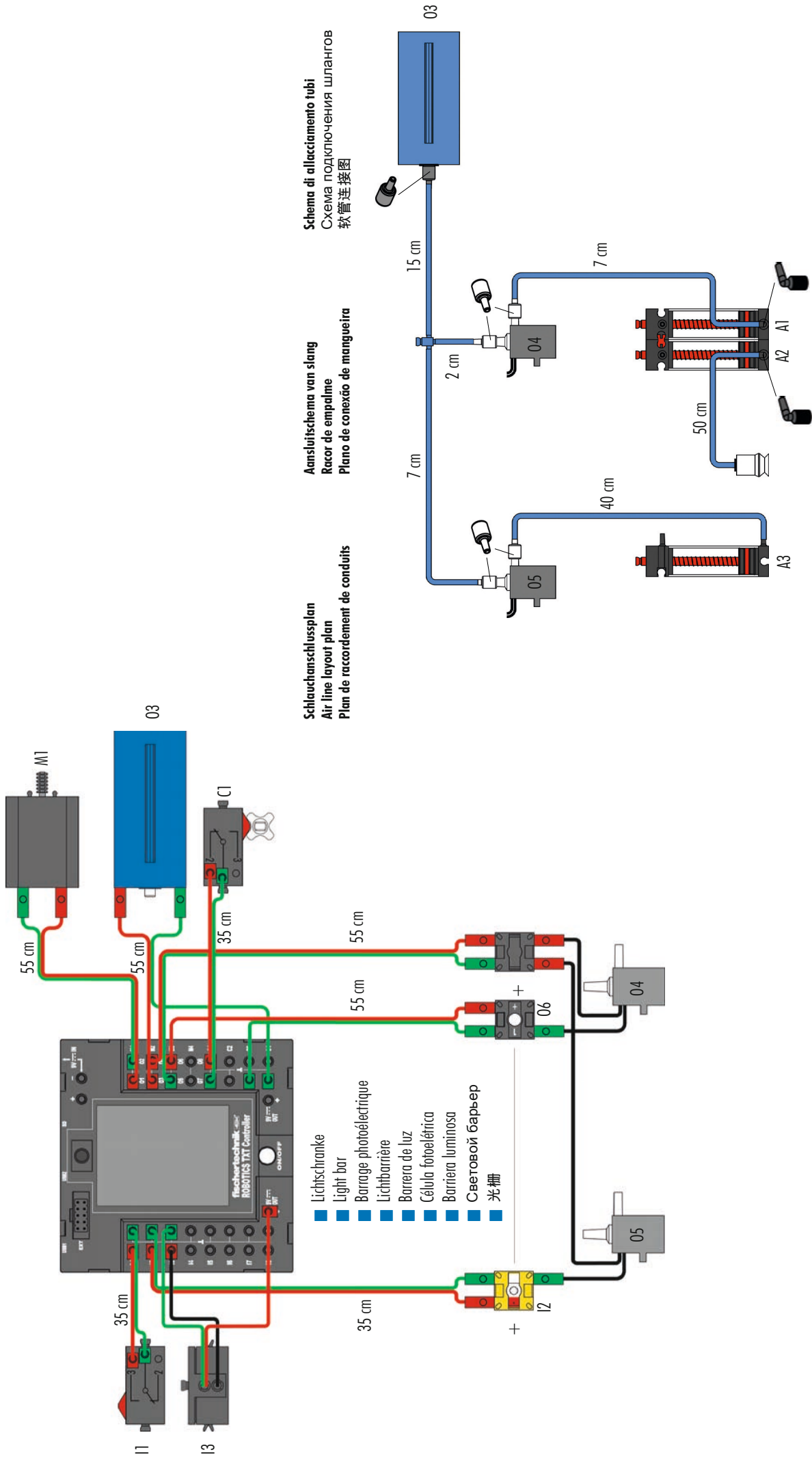

Schlauchanschlussplan
Air line layout plan
Plan de raccordement de conduits

Aansluitschema van slang
Racor de empalme
Plano de conexão de mangueira

Schema di allacciamento tubi
Схема подключения шлангов
软管连接图

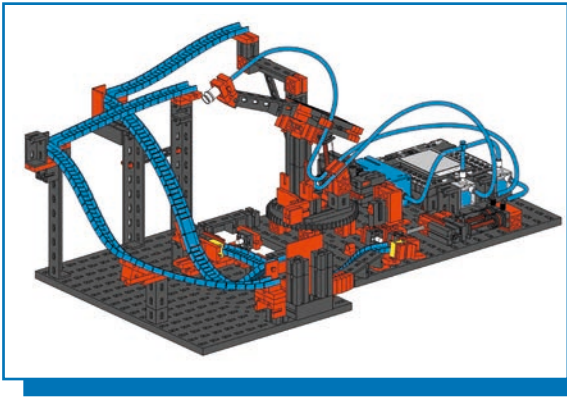

Kugelparcours mit Vakuumgreifer

Ball obstacle course with vacuum picker arm

Parcours à billes avec grappin pneumatique

Kogelparcour met vacuümgreijer

Pista de recorrido de bola con manipulador de vacío

Circuito de esferas com agarrador a vácuo

Percorso sfere con pinza a ventosa

Трасса для шарика с вакуумным захватом
配分选机器人的滚珠弯道

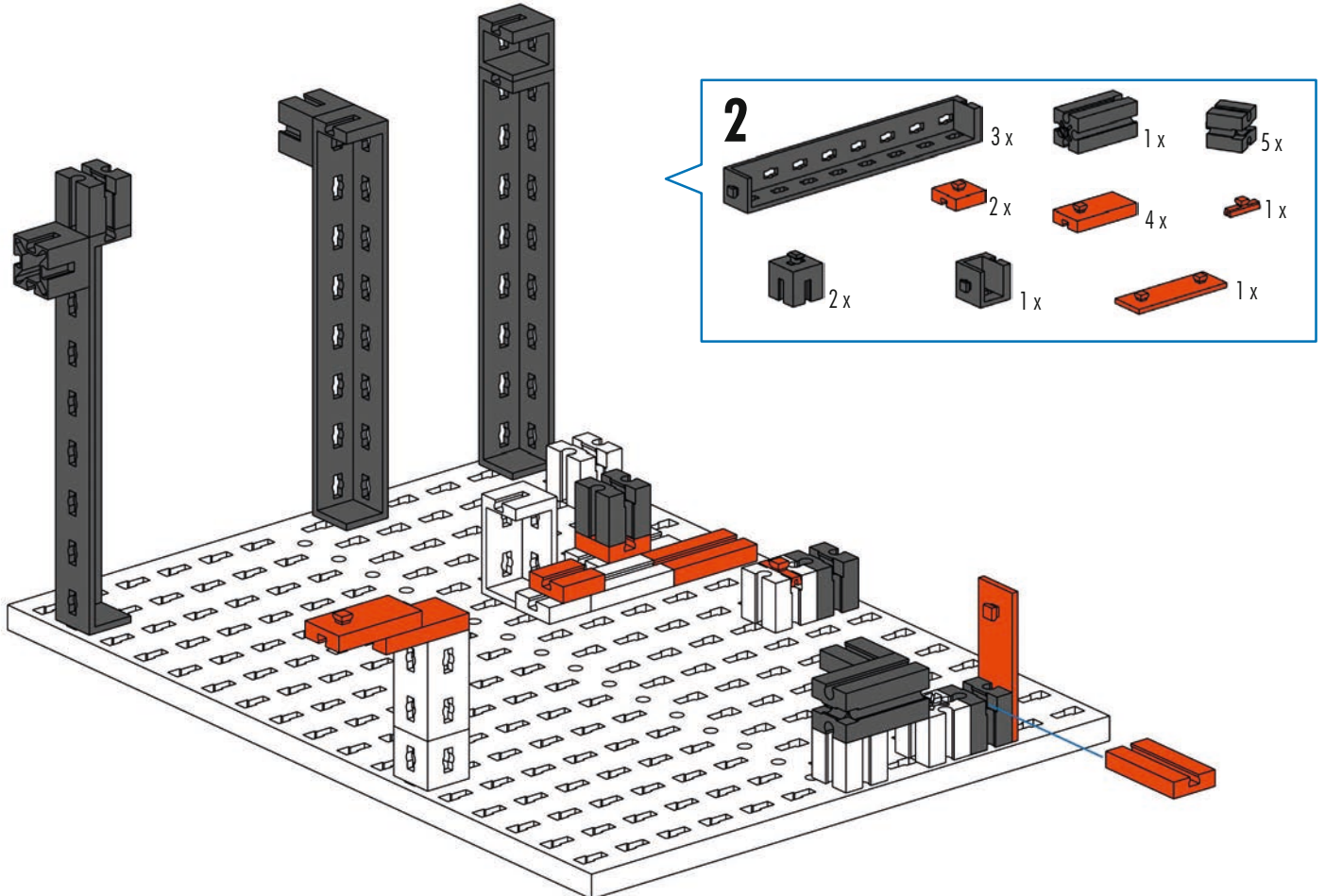
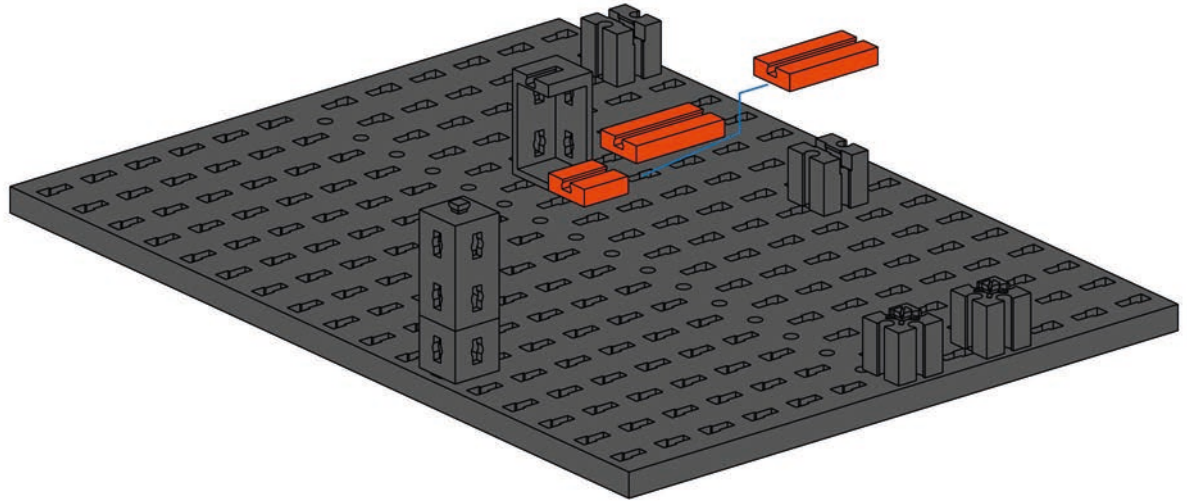
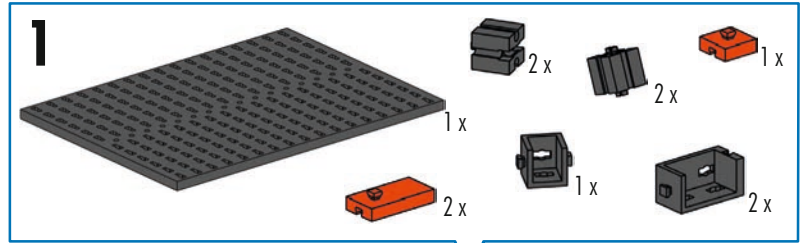

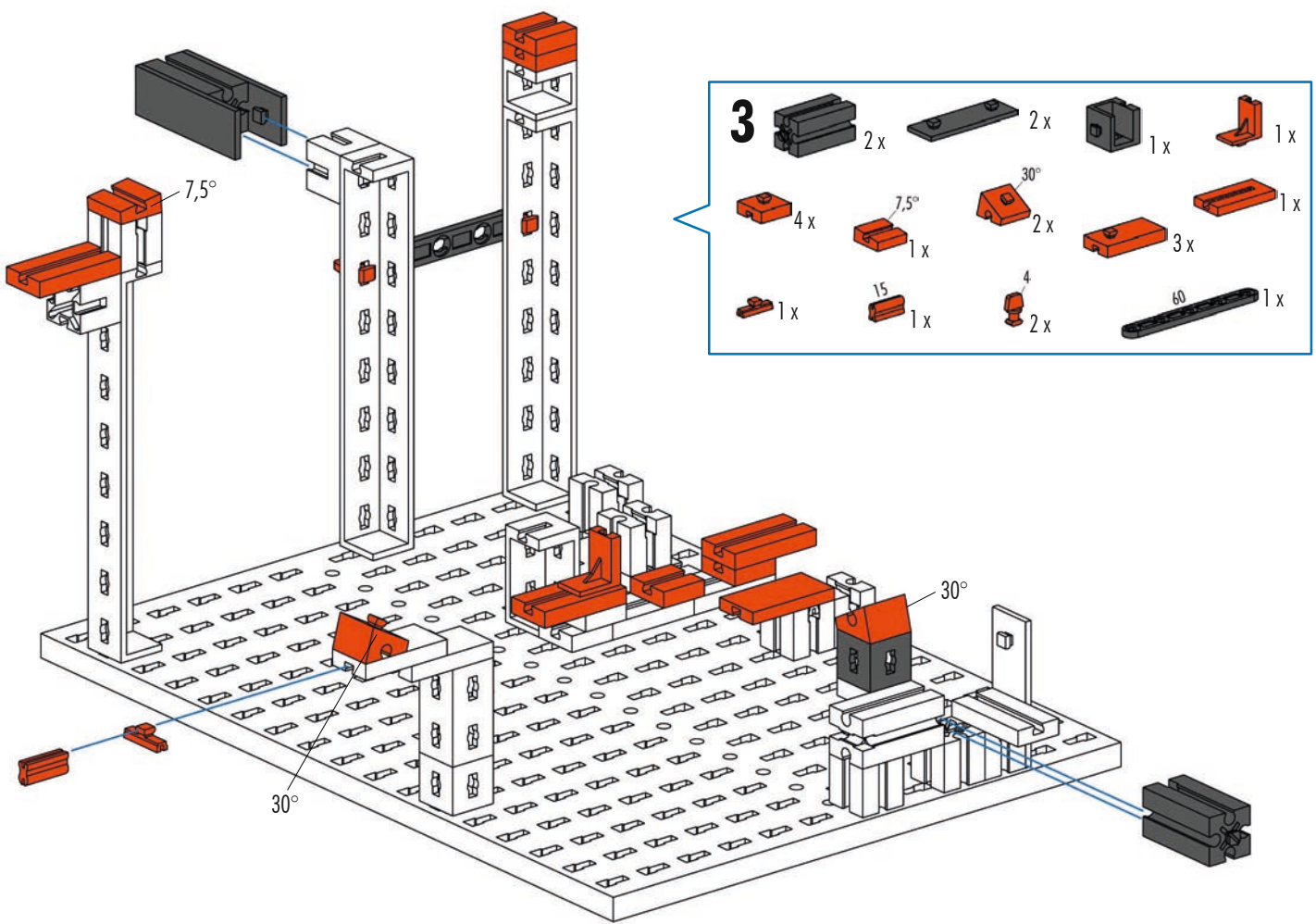

- 3**
- 2x [Grey 2-hole Technic beam]
 - 2x [Grey 1-hole Technic beam]
 - 1x [Grey 1-hole Technic beam]
 - 1x [Orange L-shaped Technic connector]
 - 4x [Orange 1-hole Technic beam]
 - 1x [Orange 7.5° Technic beam]
 - 2x [Orange 30° Technic beam]
 - 1x [Orange 3-hole Technic beam]
 - 1x [Orange 1-hole Technic beam]
 - 1x [Orange 15° Technic beam]
 - 2x [Orange 4-hole Technic beam]
 - 1x [Black 60-hole Technic beam]

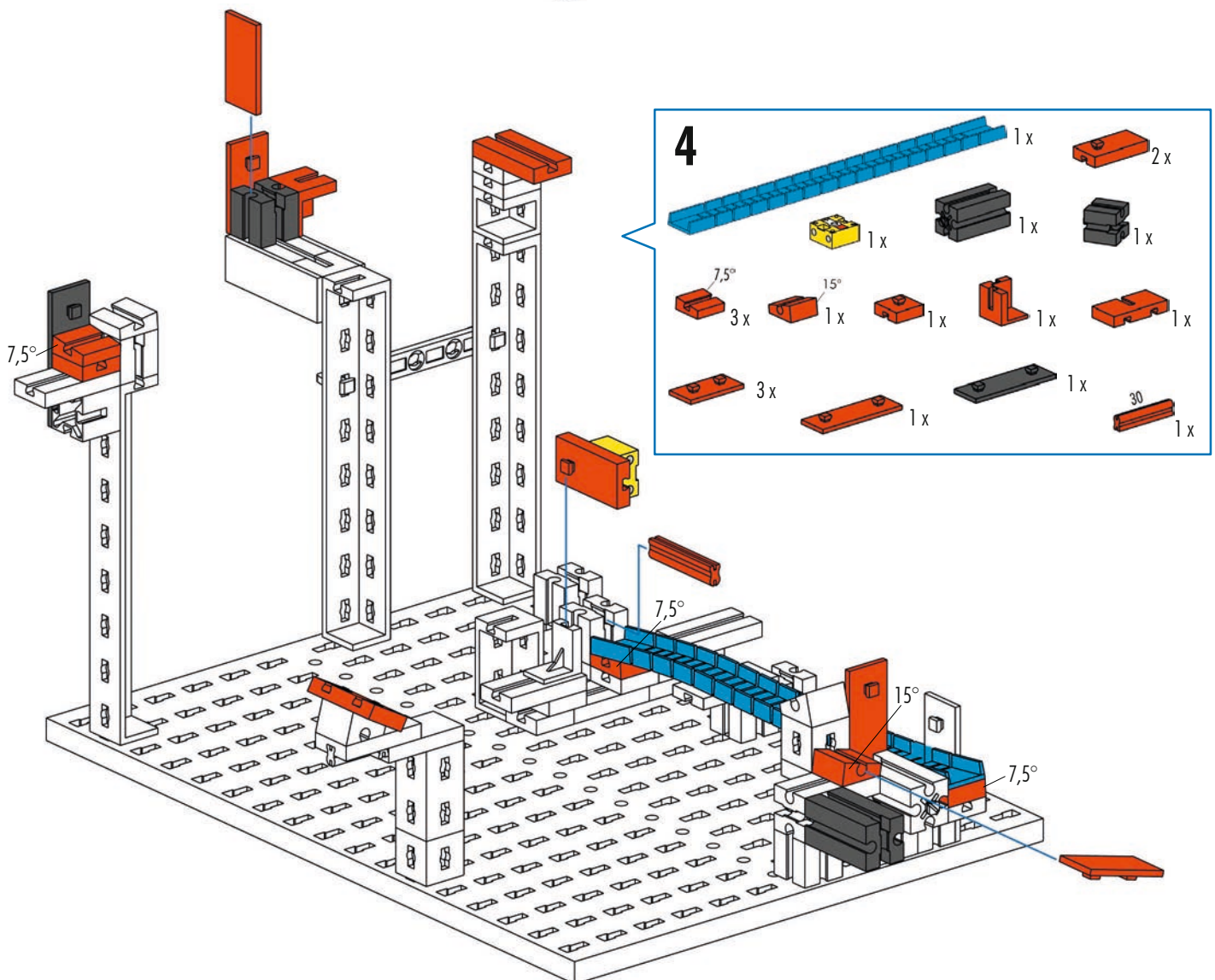

- 4**
- 1x [Blue 1-hole Technic beam]
 - 2x [Orange 1-hole Technic beam]
 - 1x [Yellow 1-hole Technic beam]
 - 1x [Grey 2-hole Technic beam]
 - 1x [Grey 1-hole Technic beam]
 - 3x [Orange 7.5° Technic beam]
 - 1x [Orange 15° Technic beam]
 - 1x [Orange 1-hole Technic beam]
 - 1x [Orange L-shaped Technic connector]
 - 1x [Orange 1-hole Technic beam]
 - 3x [Orange 1-hole Technic beam]
 - 1x [Orange 1-hole Technic beam]
 - 1x [Grey 1-hole Technic beam]
 - 1x [Black 1-hole Technic beam]
 - 1x [Orange 30° Technic beam]

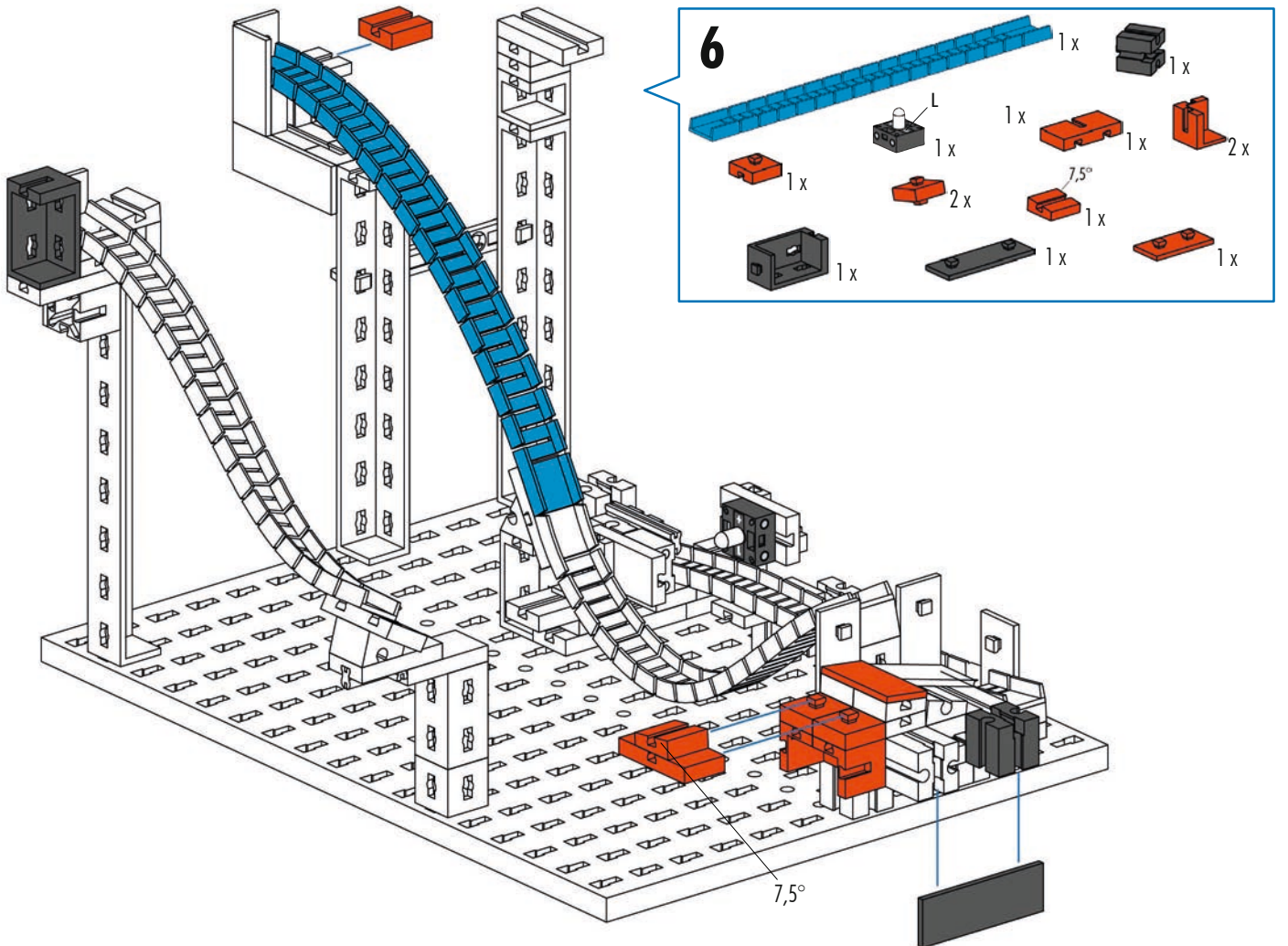
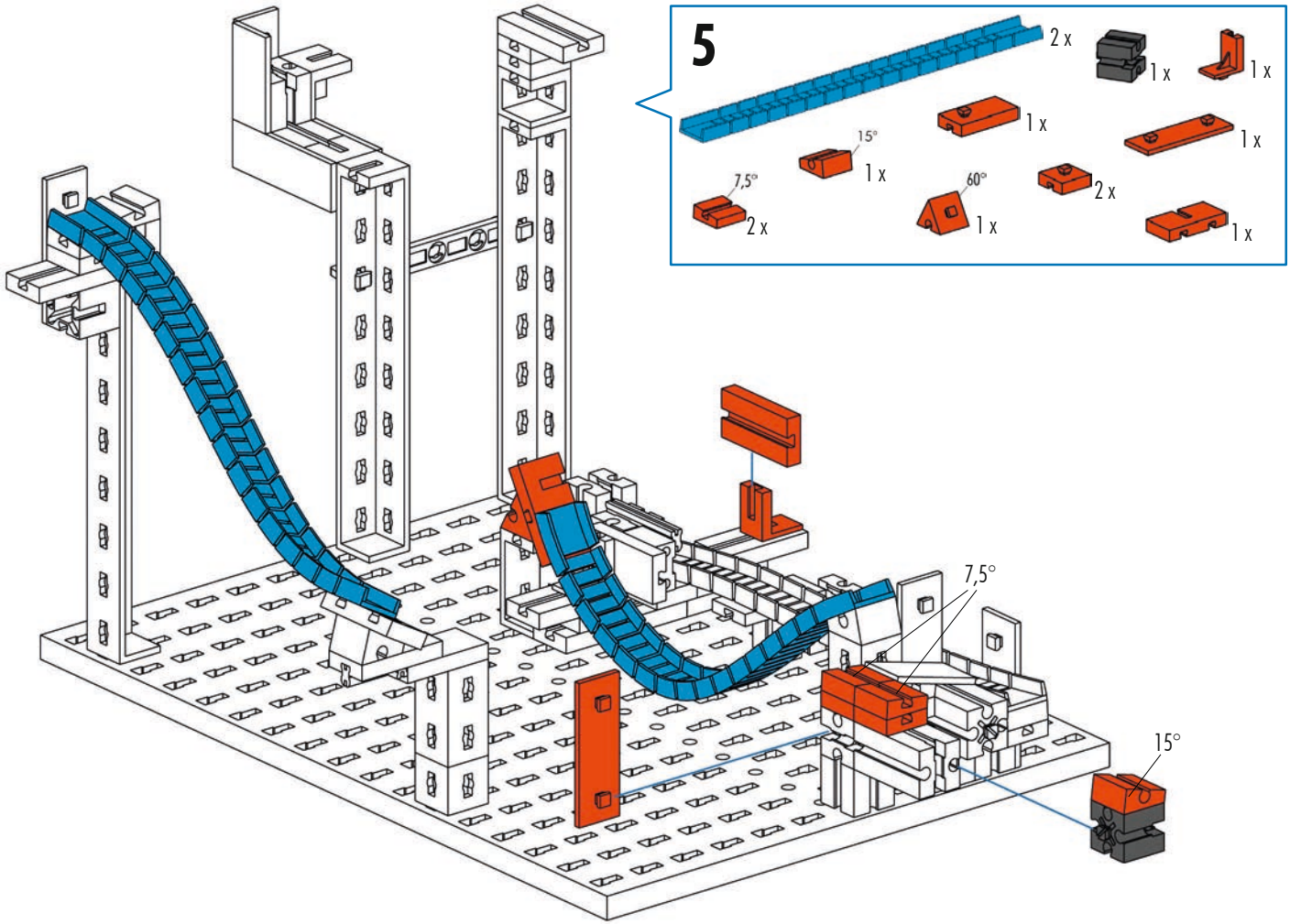

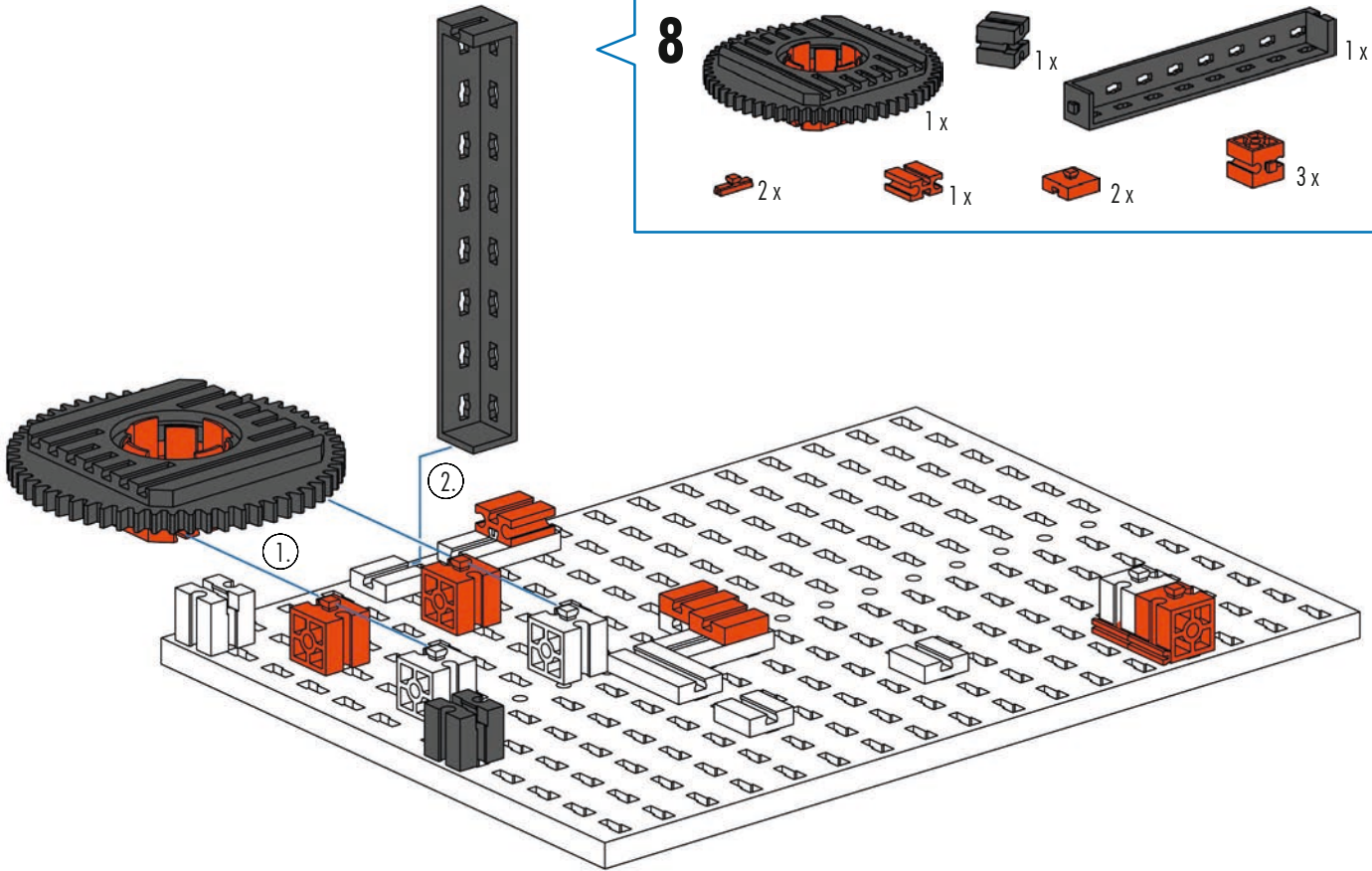
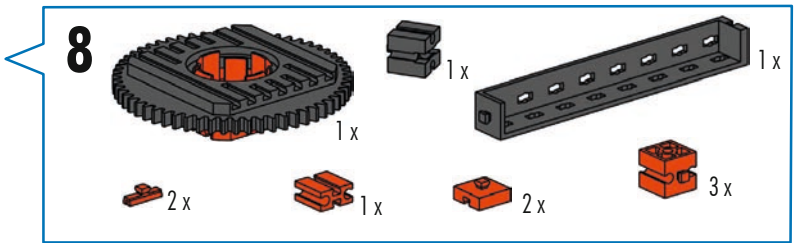
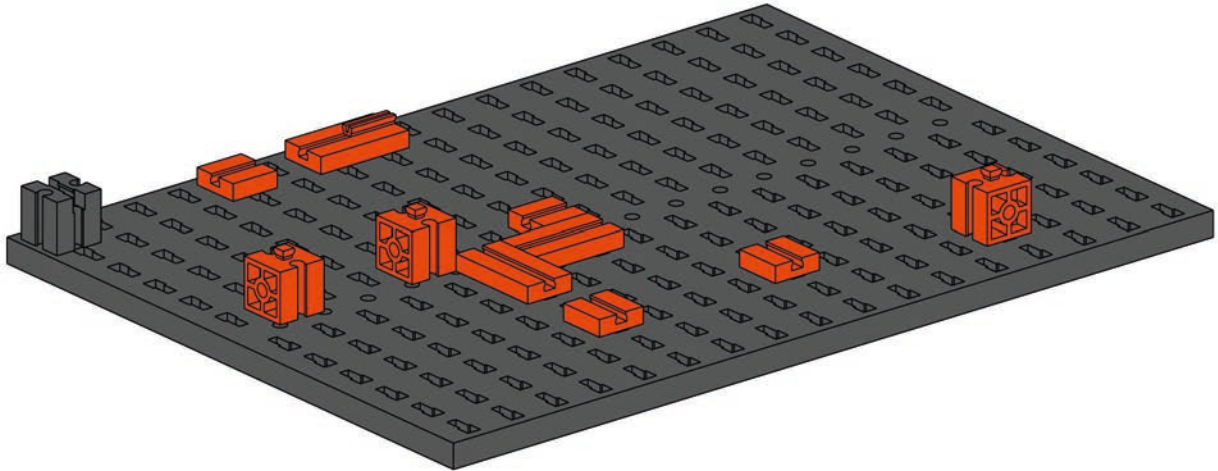
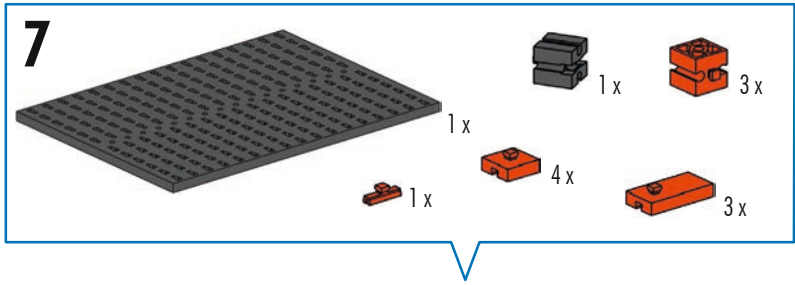

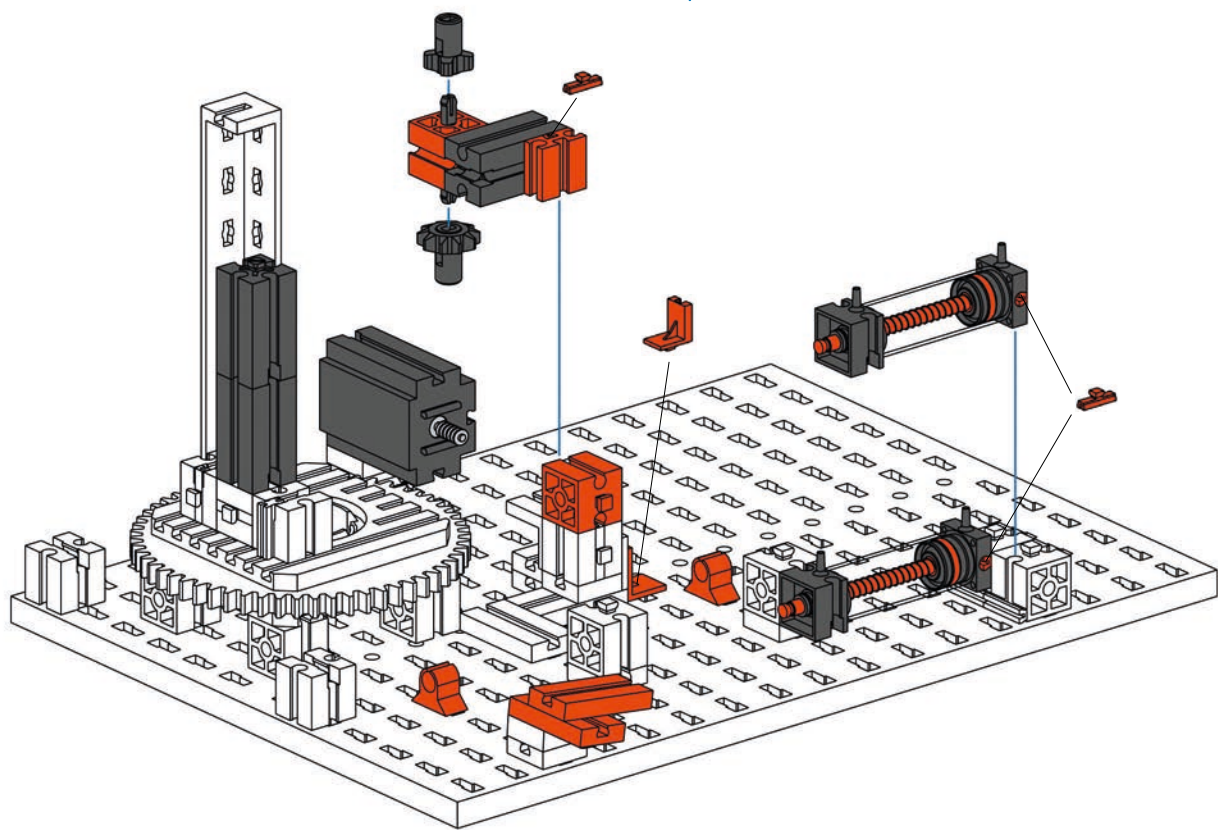
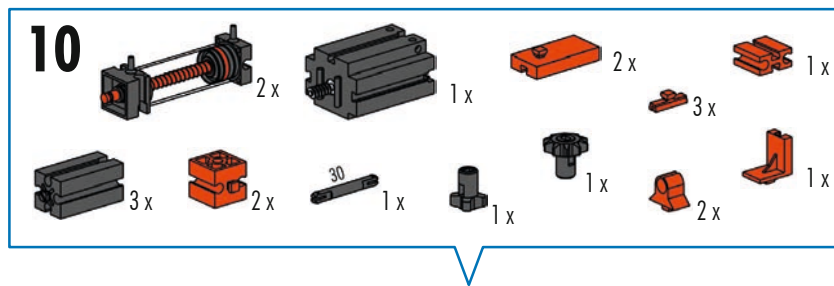
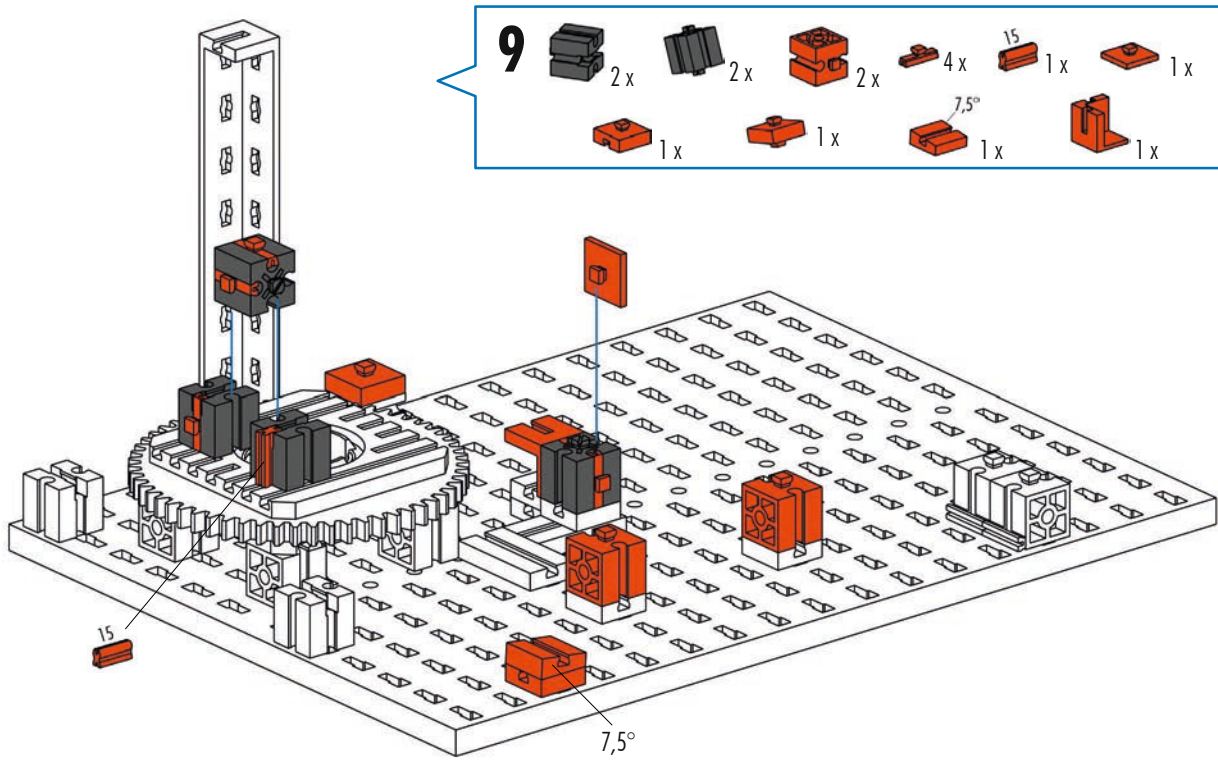

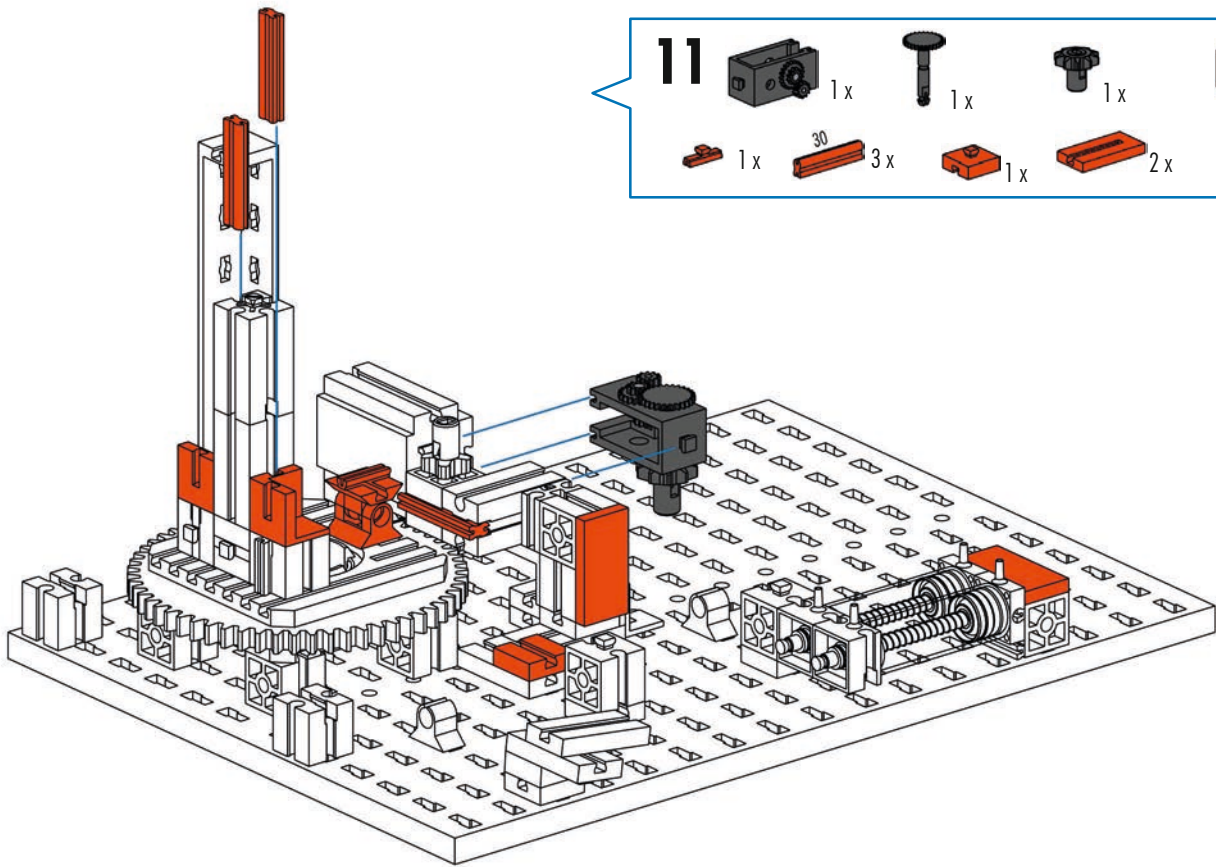

- 11**
- 1x [Grey Motor]
 - 1x [Grey Pin]
 - 1x [Grey Pin]
 - 2x [Orange L-Bracket]
 - 1x [Orange Pin]
 - 3x [Orange Pin 30]
 - 1x [Orange Pin]
 - 2x [Orange Pin]
 - 1x [Orange Connector]

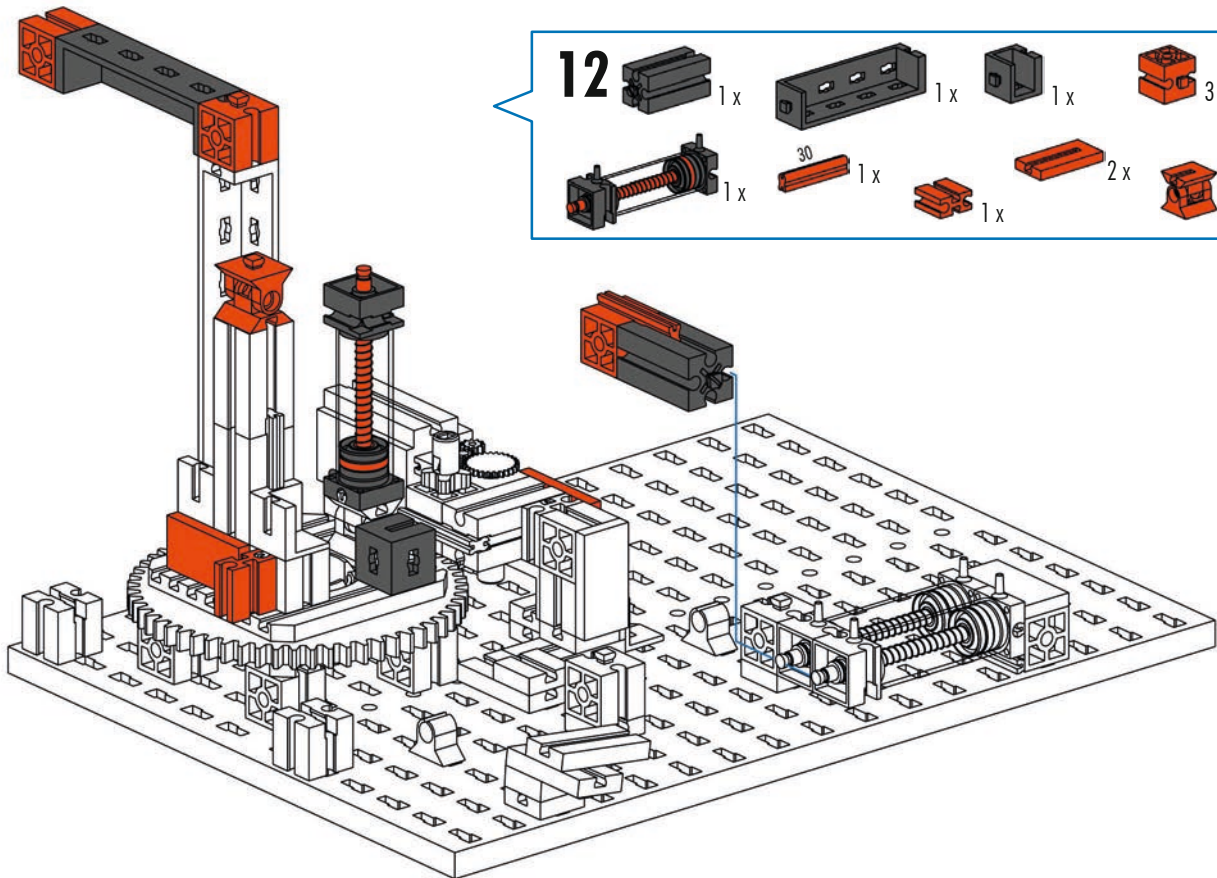

- 12**
- 1x [Grey Motor]
 - 1x [Grey Pin]
 - 1x [Grey Pin]
 - 3x [Orange L-Bracket]
 - 1x [Grey Pin]
 - 1x [Orange Pin 30]
 - 1x [Orange Pin]
 - 2x [Orange Pin]
 - 1x [Orange Connector]

- 13**
- 1x [Grey Motor]
 - 1x [Grey Pin]
 - 1x [Grey Pin]
 - 1x [Orange Pin 30°]
 - 1x [Orange Pin 15°]
 - 1x [Orange Pin 7.5°]

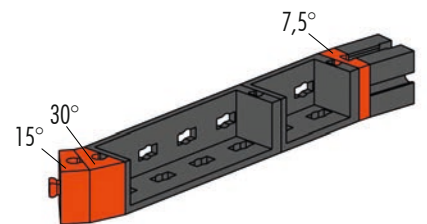

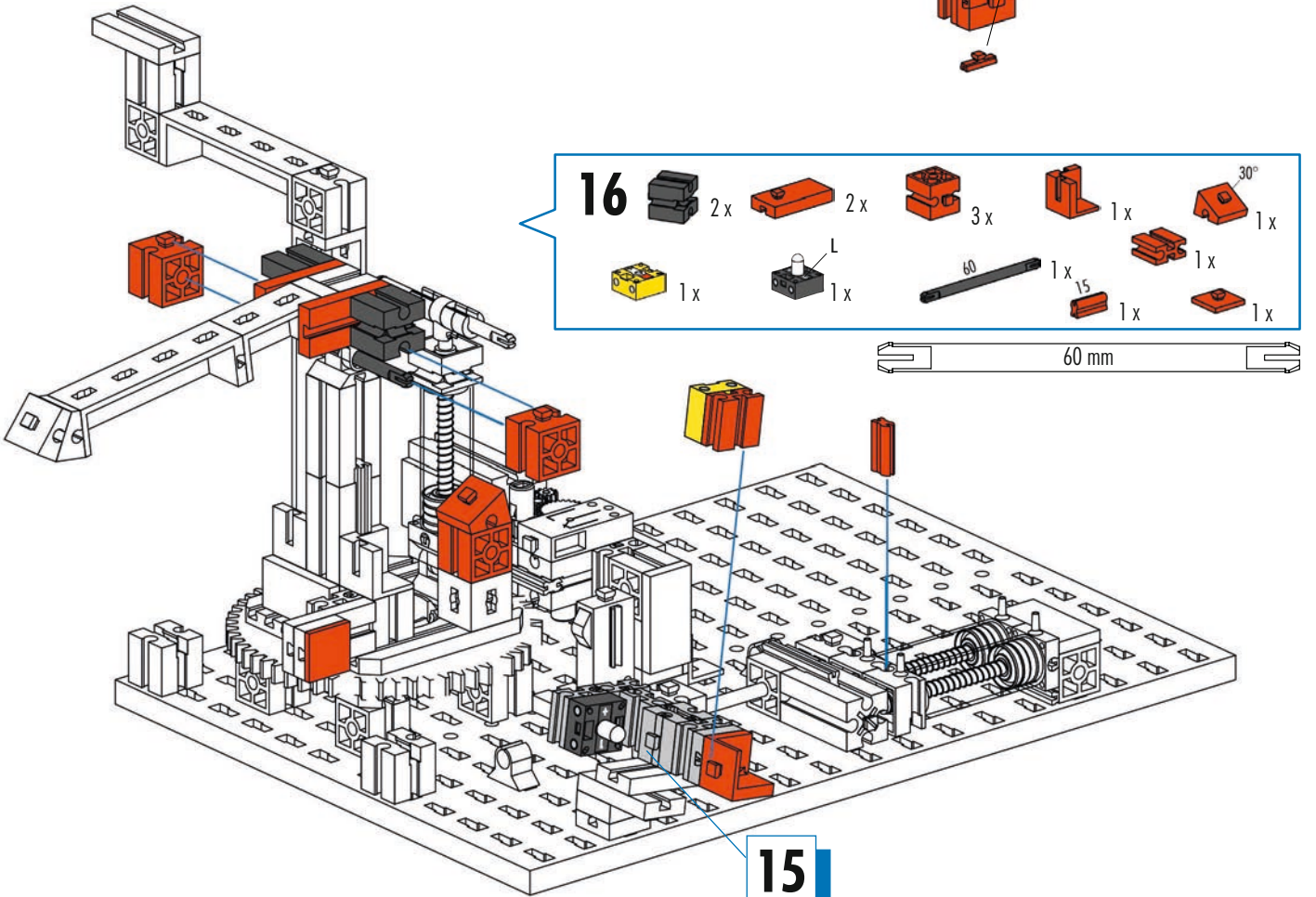
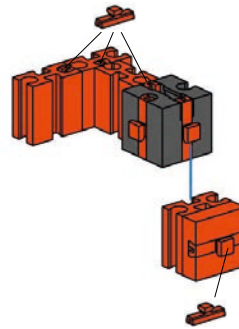
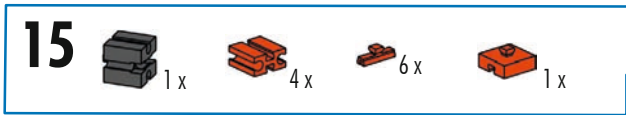
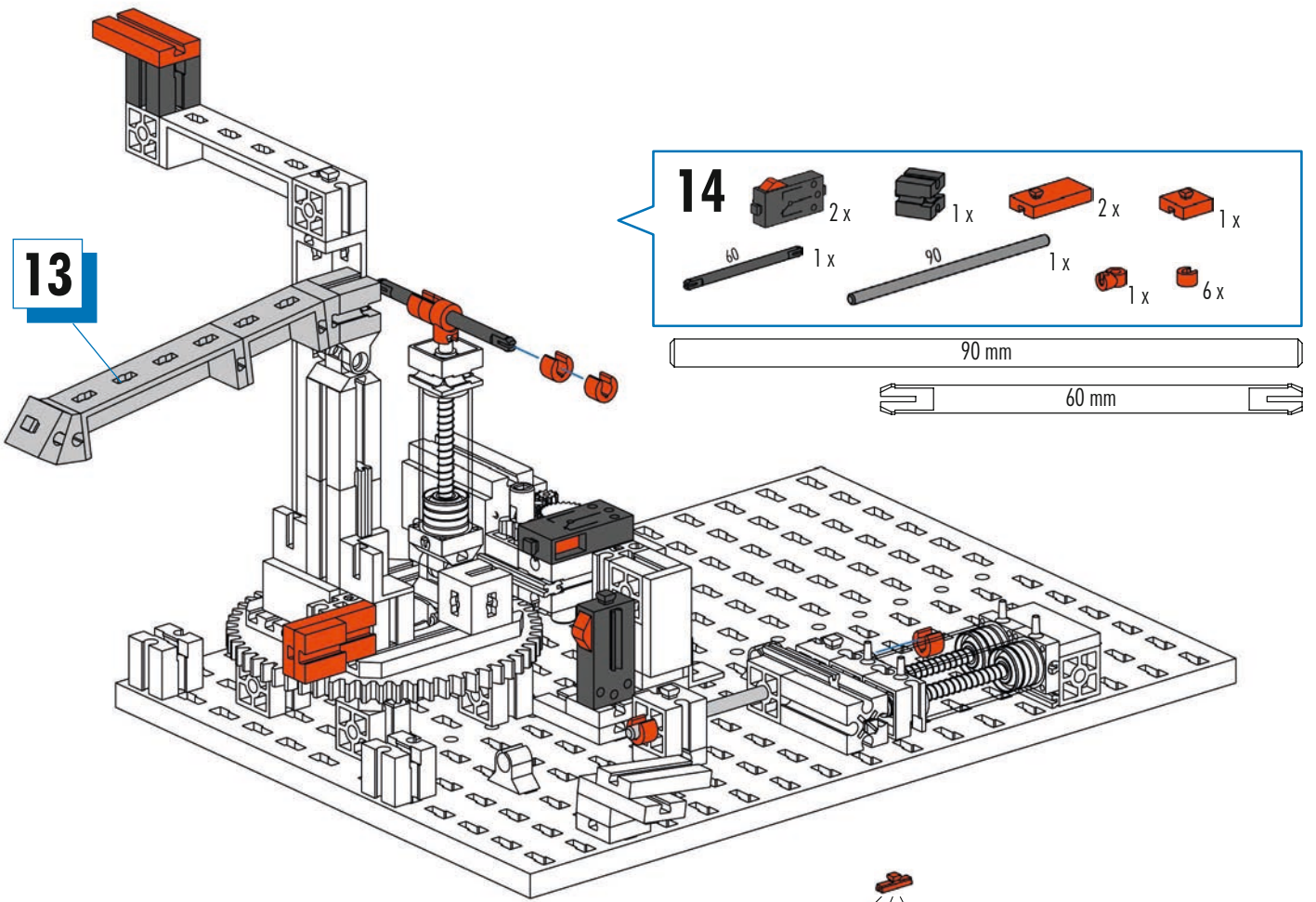

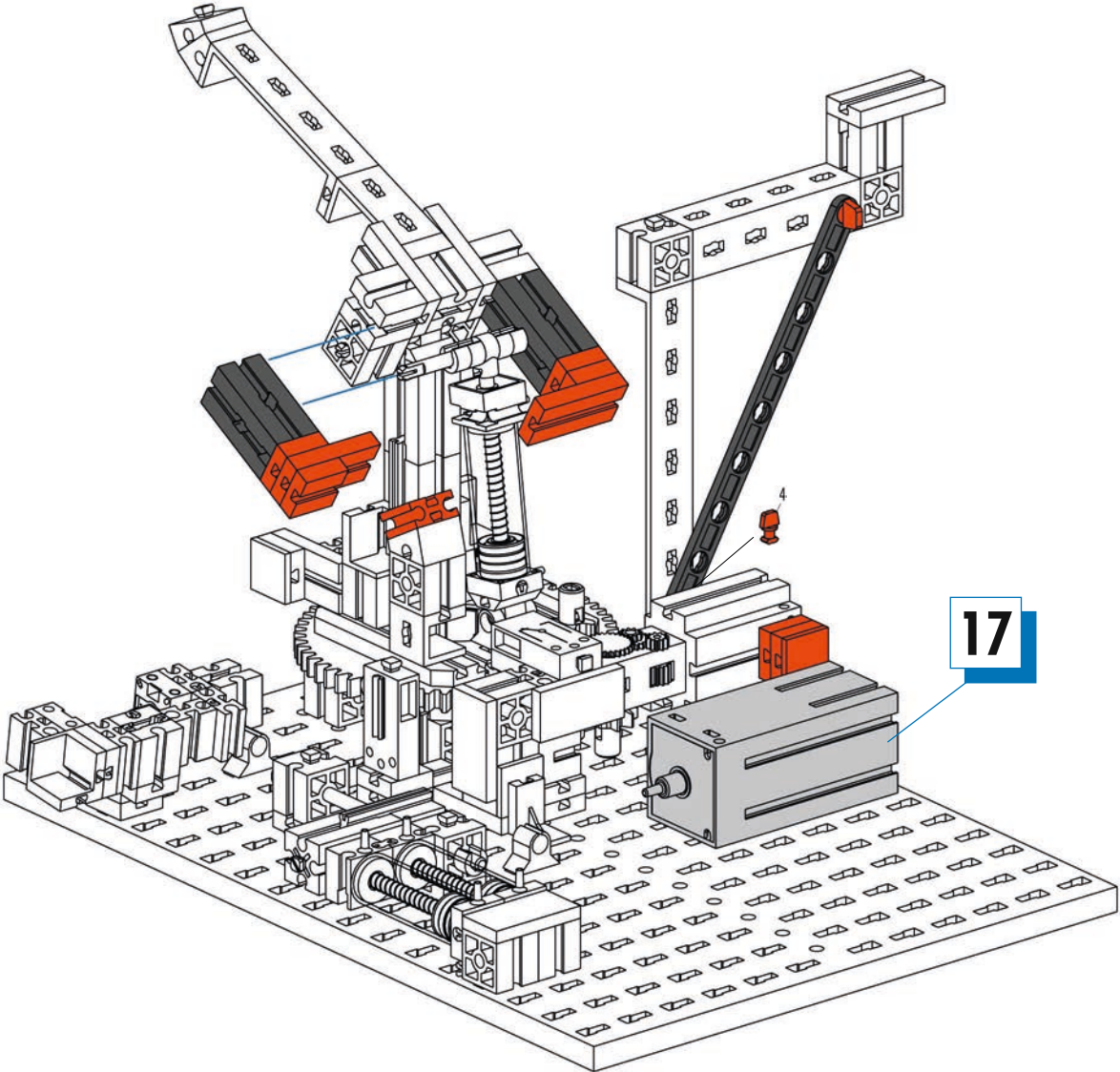
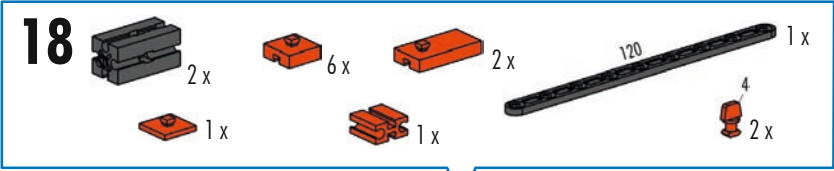
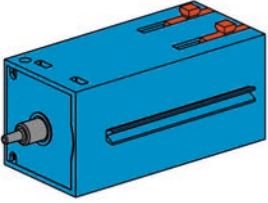
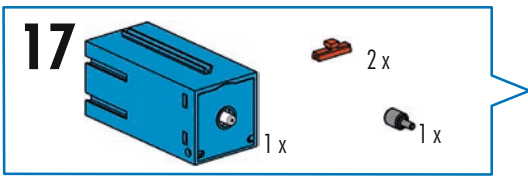

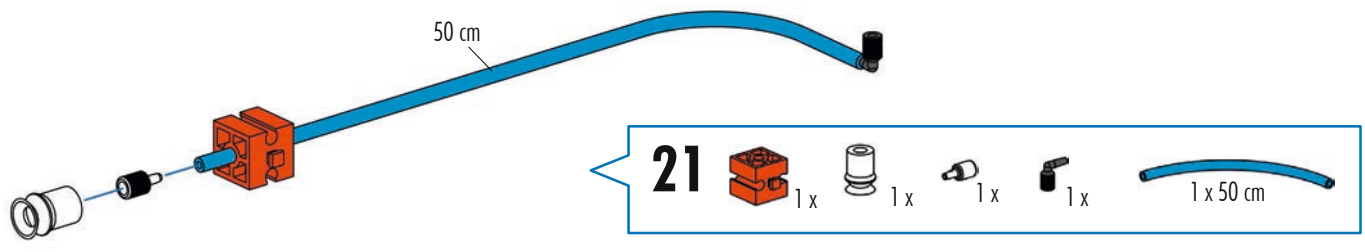
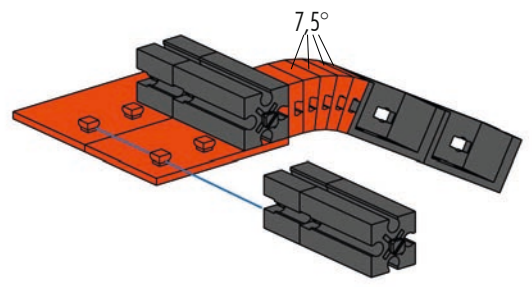
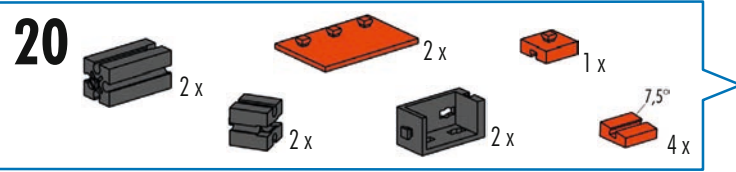
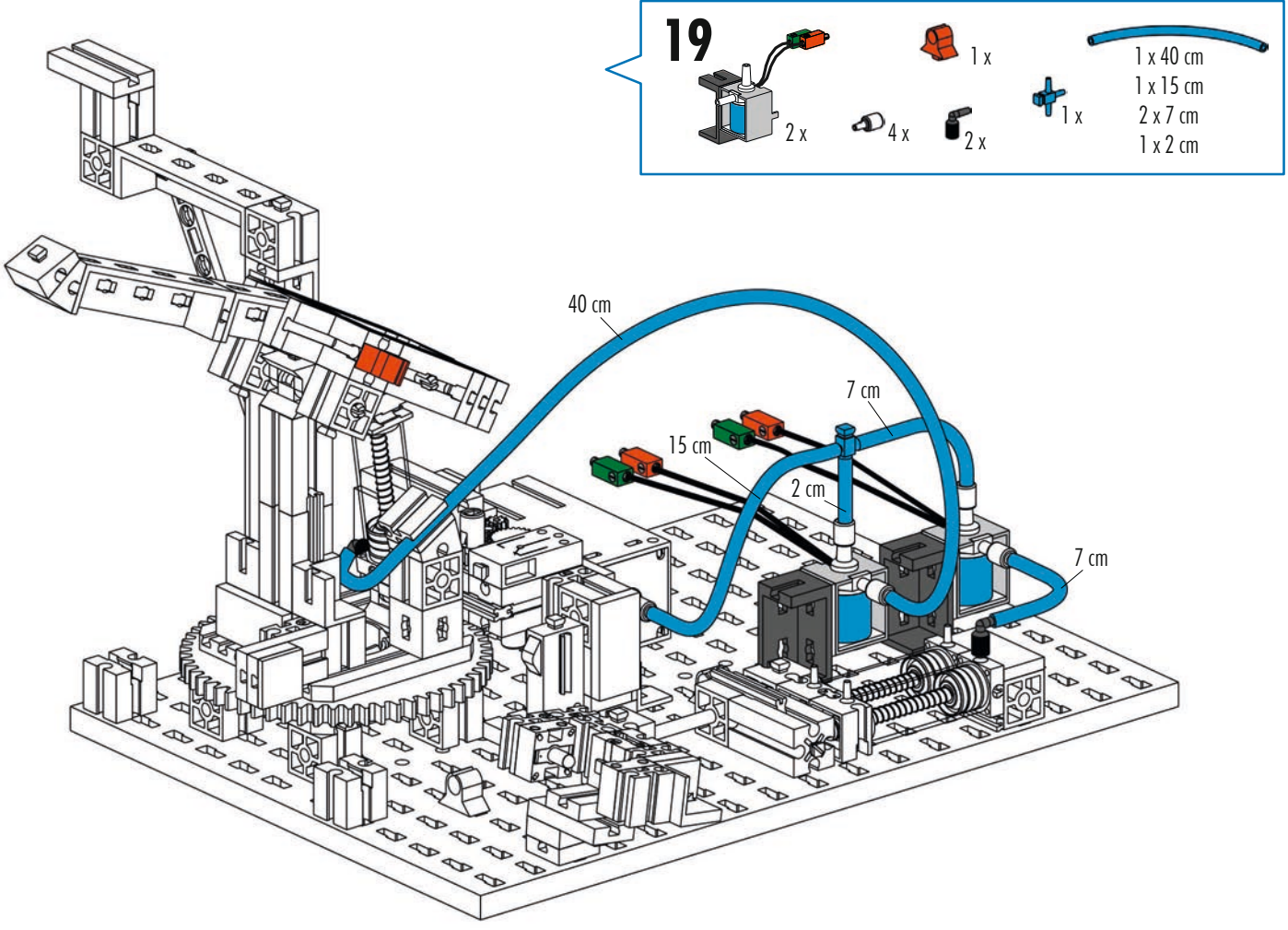

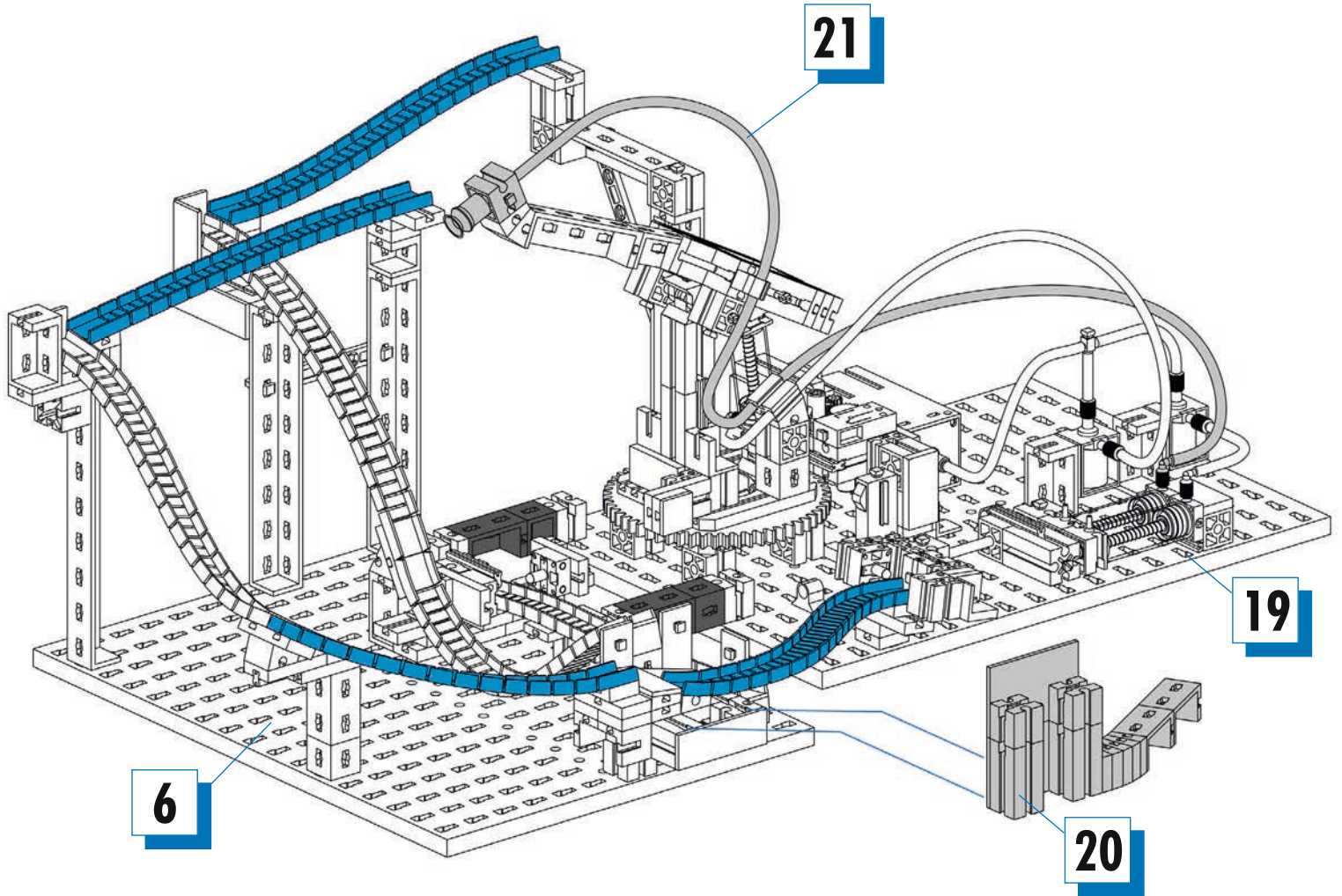
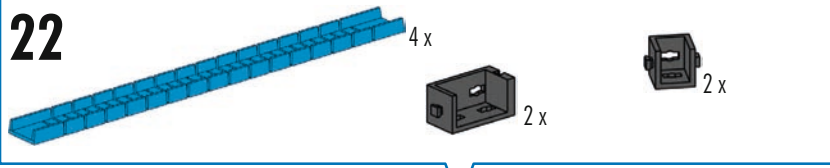
22

- ROBO TXT Controller (Art.-Nr. 522429) nicht im Baukasten enthalten
- ROBO TXT Controller (Art.-Nr. 522429) not included in the modular kit
- ROBO TXT Controller (Art.-Nr. 522429) n'est pas contenue dans le kit
- ROBO TXT Controller (Art.-Nr. 522429) niet in de bouwdoos opgenomen
- ROBO TXT Controller (Art.-Nr. 522429) no está incluido en el conjunto
- ROBO TXT Controller (Art.-Nr. 522429) não contido no sistema de construção por blocos
- ROBO TXT Controller (Art.-Nr. 522429) non incluso nella scatola di montaggio
- ROBO TXT Controller (Art.-Nr. 522429) не входит в комплект конструктора
- ROBO TXT Controller (Art.-Nr. 522429) 不包含在组件

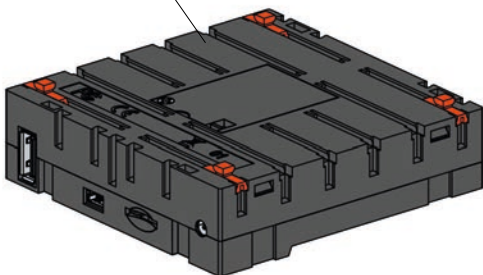
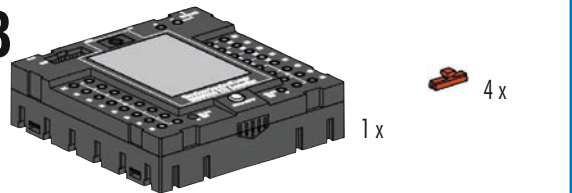
**18**

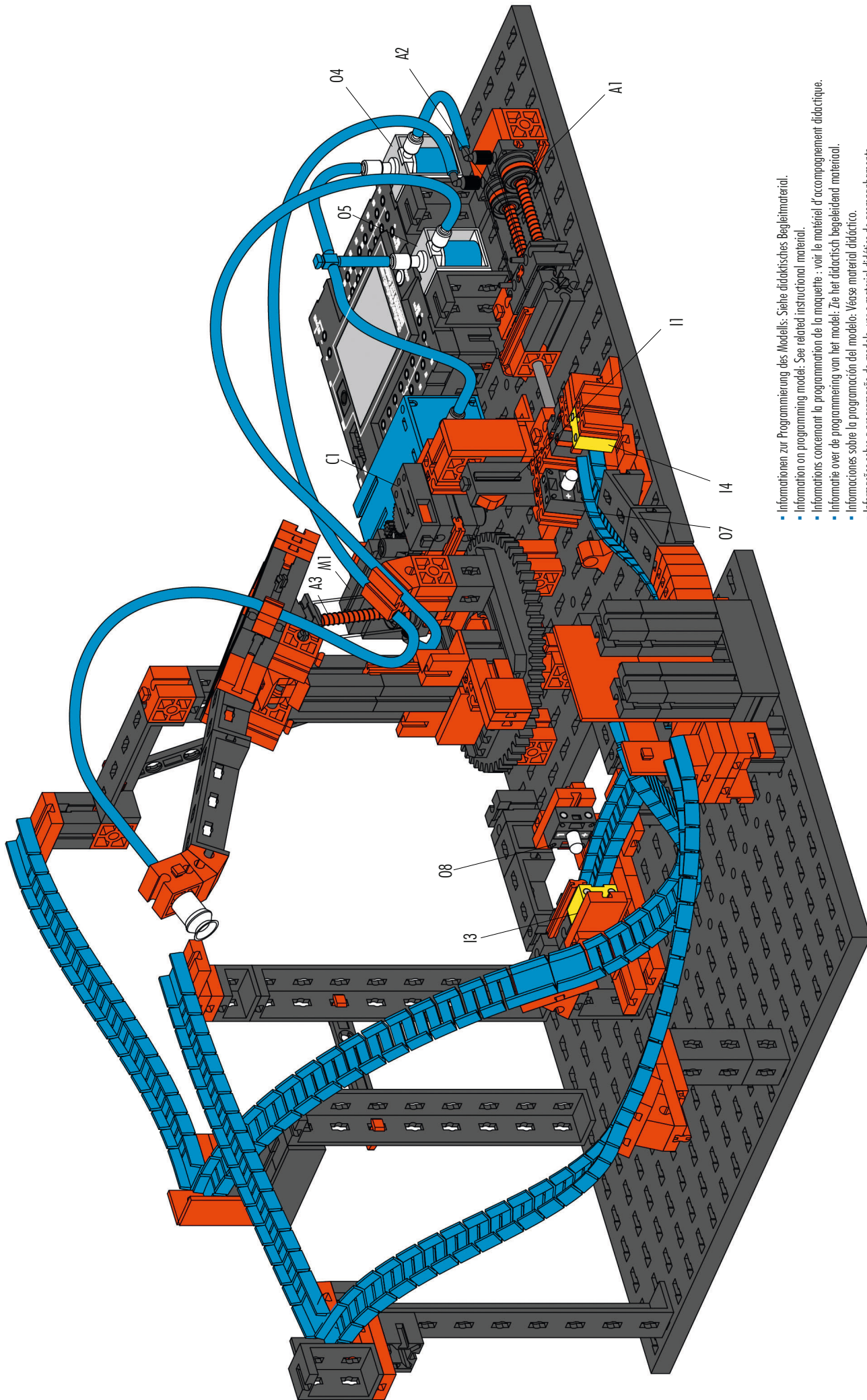

- Informationen zur Programmierung des Modells: Siehe didaktisches Begleitmaterial.
- Information on programming model: See related instructional material.
- Informations concernant la programmation de la maquette : voir le matériel d'accompagnement didactique.
- Informatie over de programmering van het model: Zie het didactisch begeleidend materiaal.
- Informaciones sobre la programación del modelo: Véase material didáctico.
- Informações sobre a programação do modelo: ver o material didático de acompanhamento.
- Informazioni sulla programmazione del modello: vedi materiale didattico.
- Информация о программировании модели: смотрите обучающий сопроводительный материал.
- 有关该模型编程的信息：见指导性说明资料。

Schaltplan
Circuit diagram
Plan électrique

Schaltelschema
Diagrama de circuitos
Plano elétrico de ligação

Schema elettrico
Схема подключения
电路图

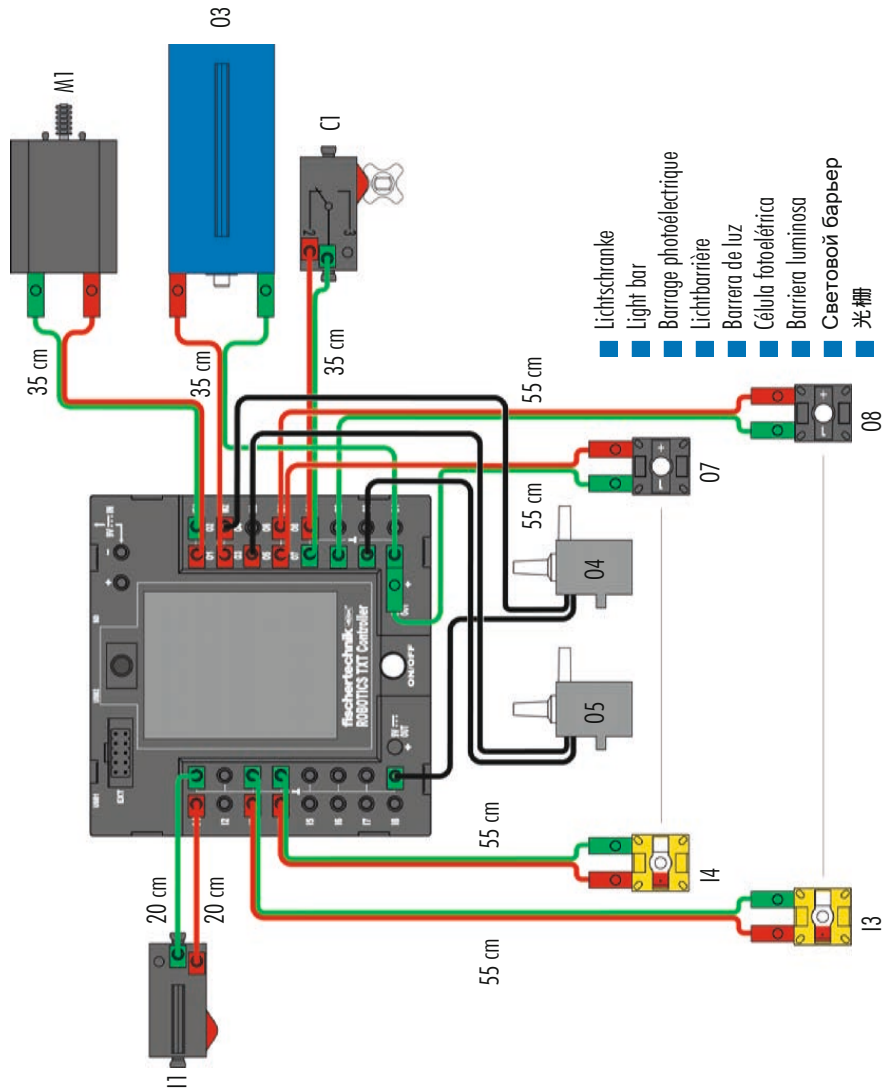

Schlauchanschlussplan
Air line layout plan
Plan de raccordement de conduits

Aansluitschema van slang
Racor de empalme
Plano de conexão de mangueira

Schema di allacciamento tubi
Схема подключения шлангов
软管连接图

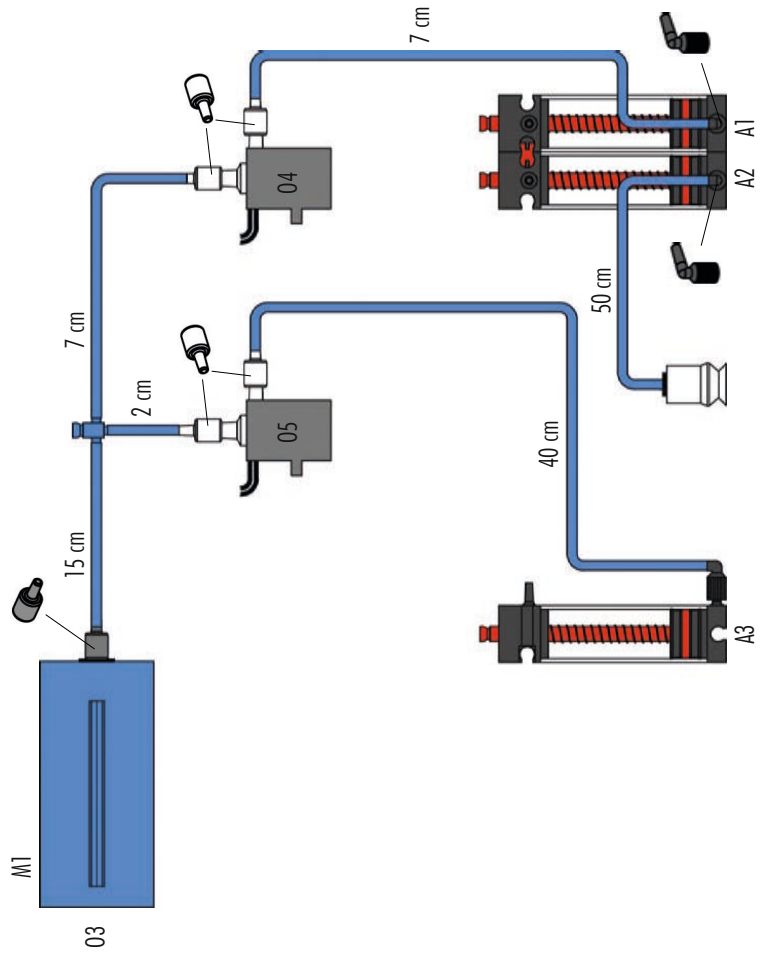

- Lichtschranke
- Light bar
- Barrage photoélectrique
- Lichtbarrière
- Barrera de luz
- Célula fotoelétrica
- Barriera luminosa
- Световой барьер
- 光栅

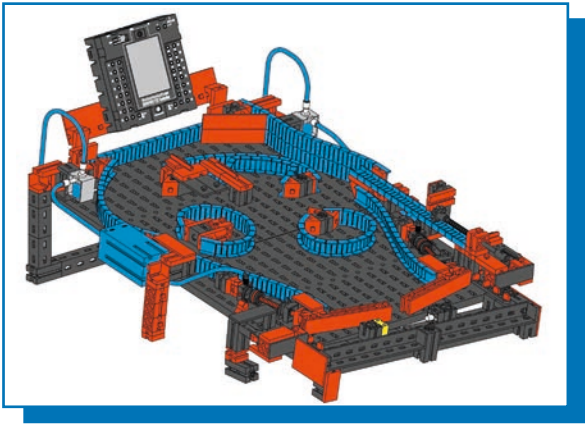

Flipper
Pinball machine
Flipper

Flipper
Pinball
Flipper

Flipper
пинбол-машина
弹球机

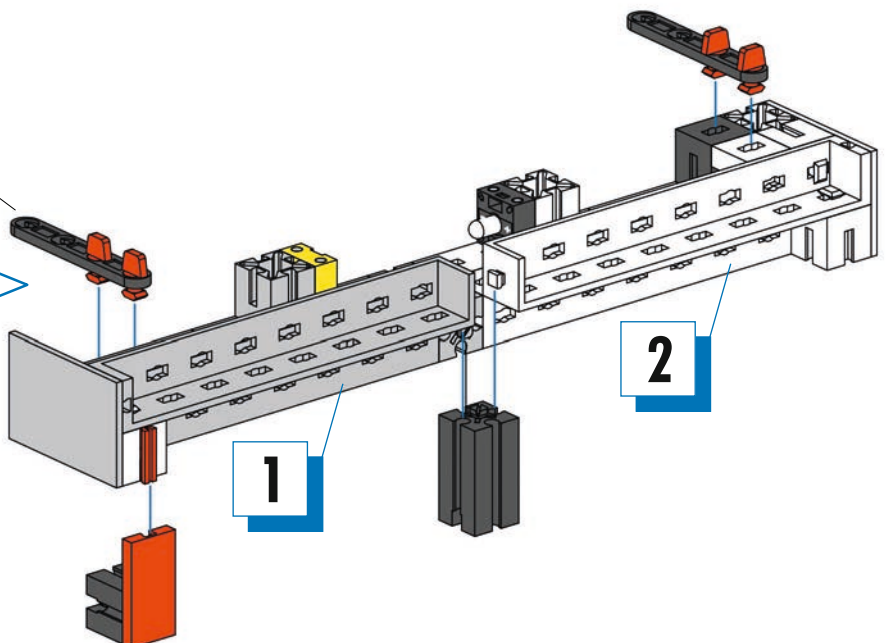
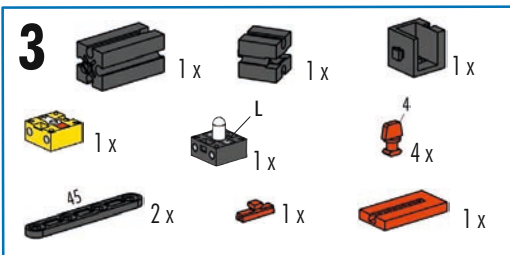
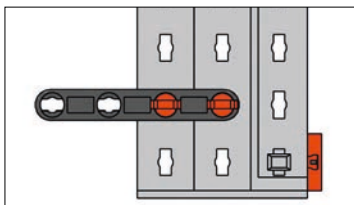
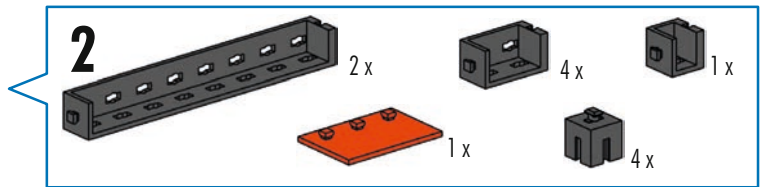
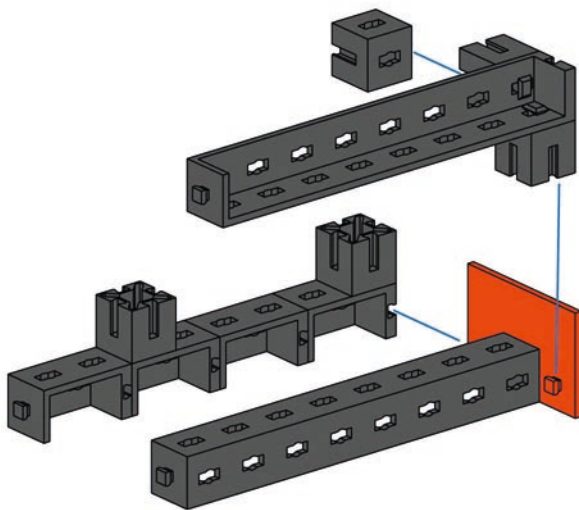
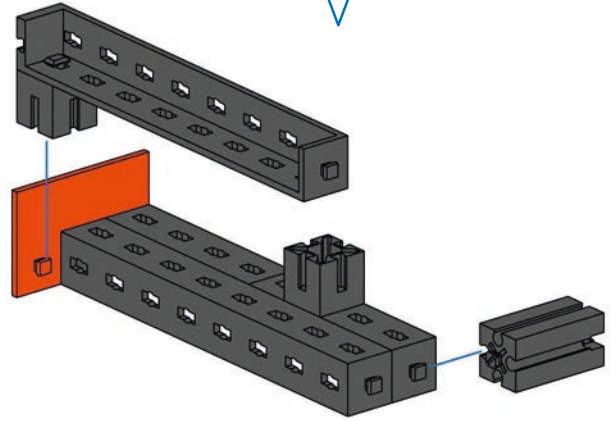
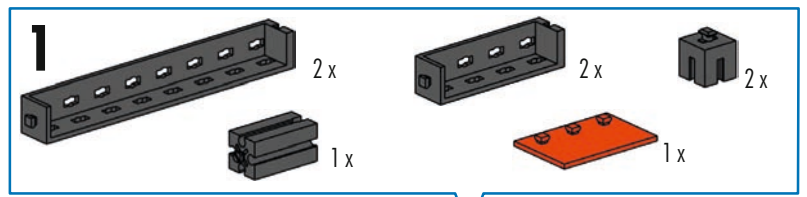

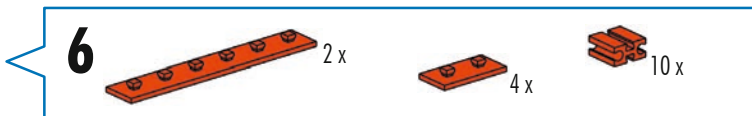
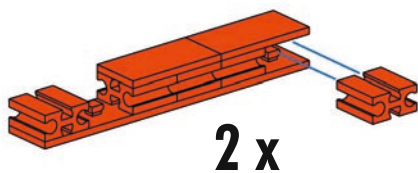
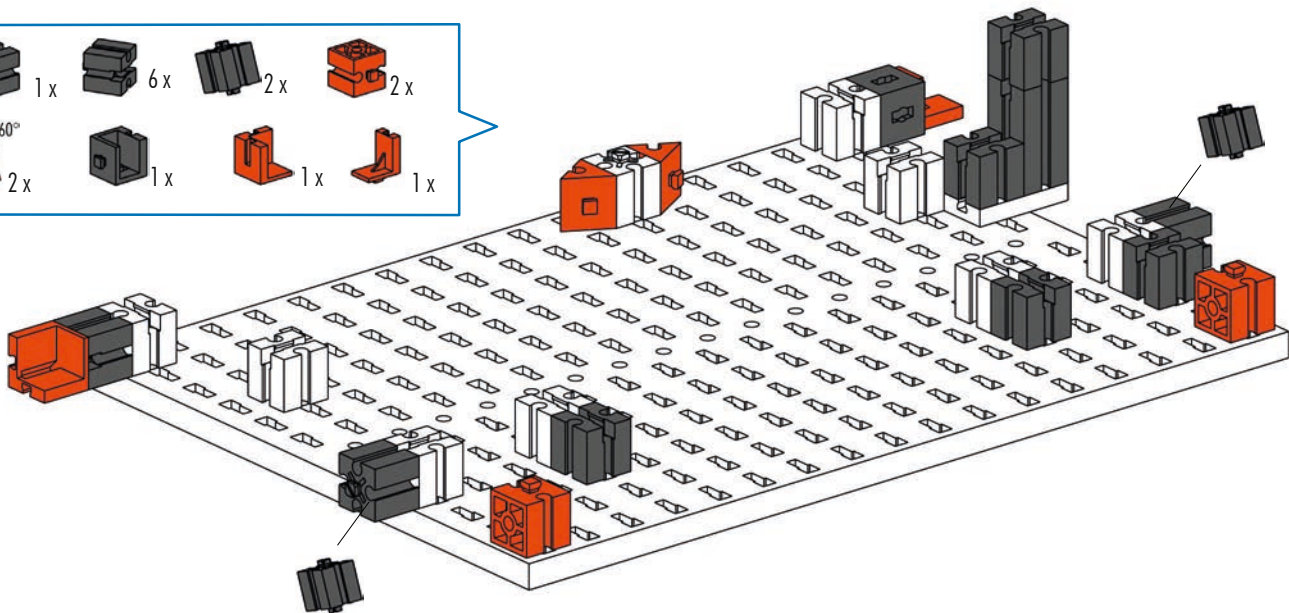
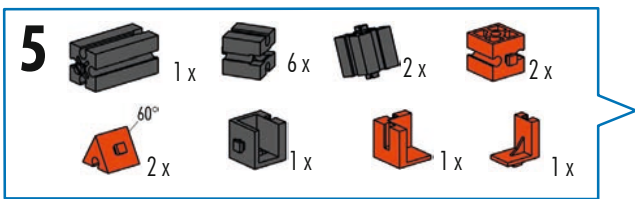
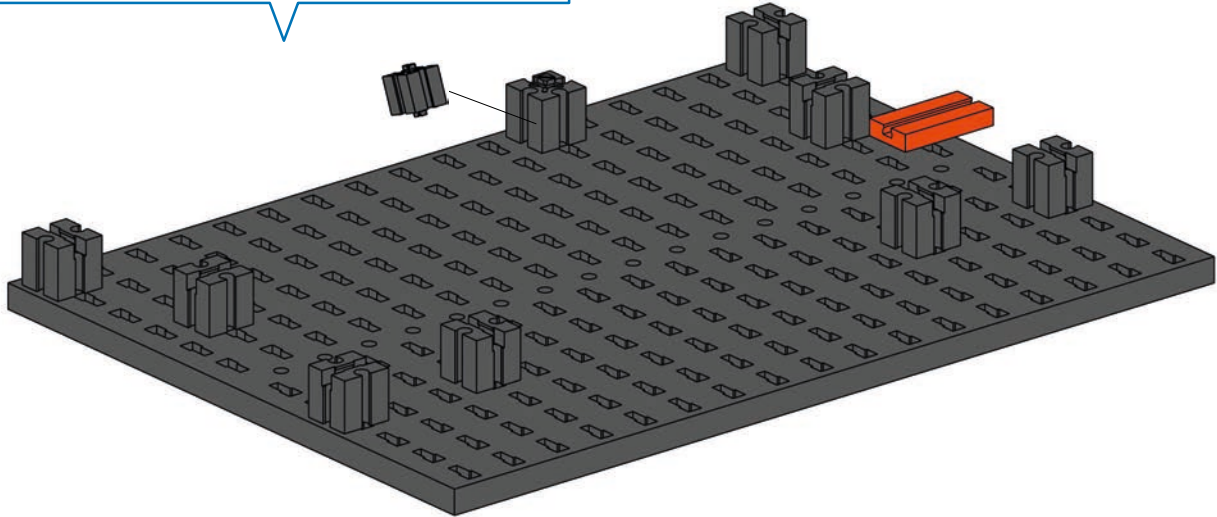
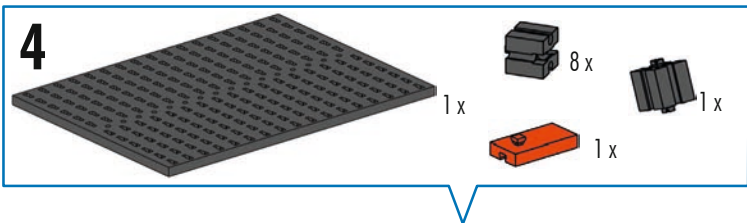

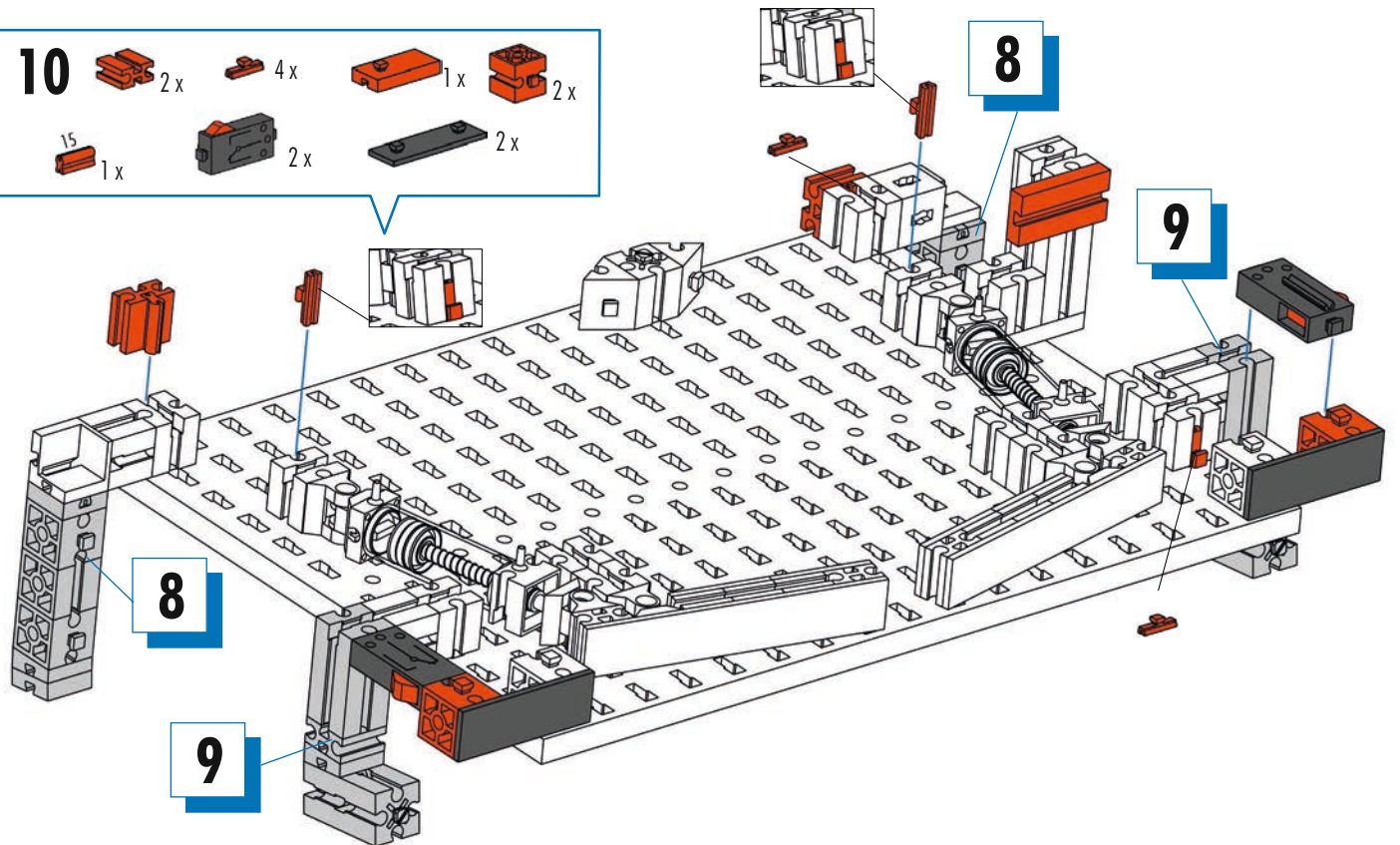
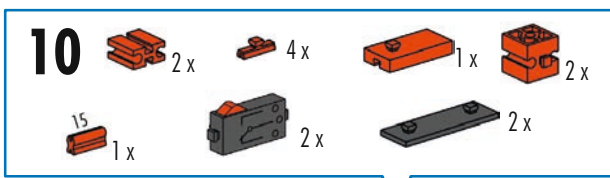
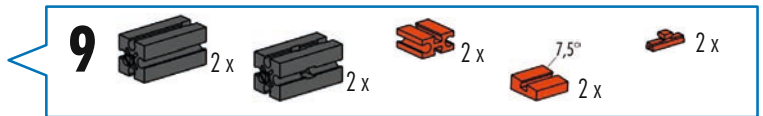
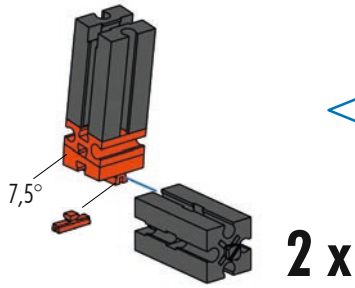
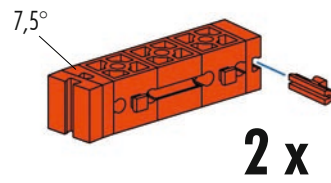
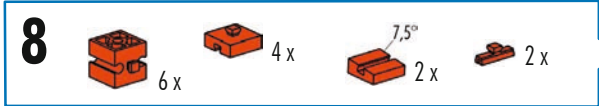
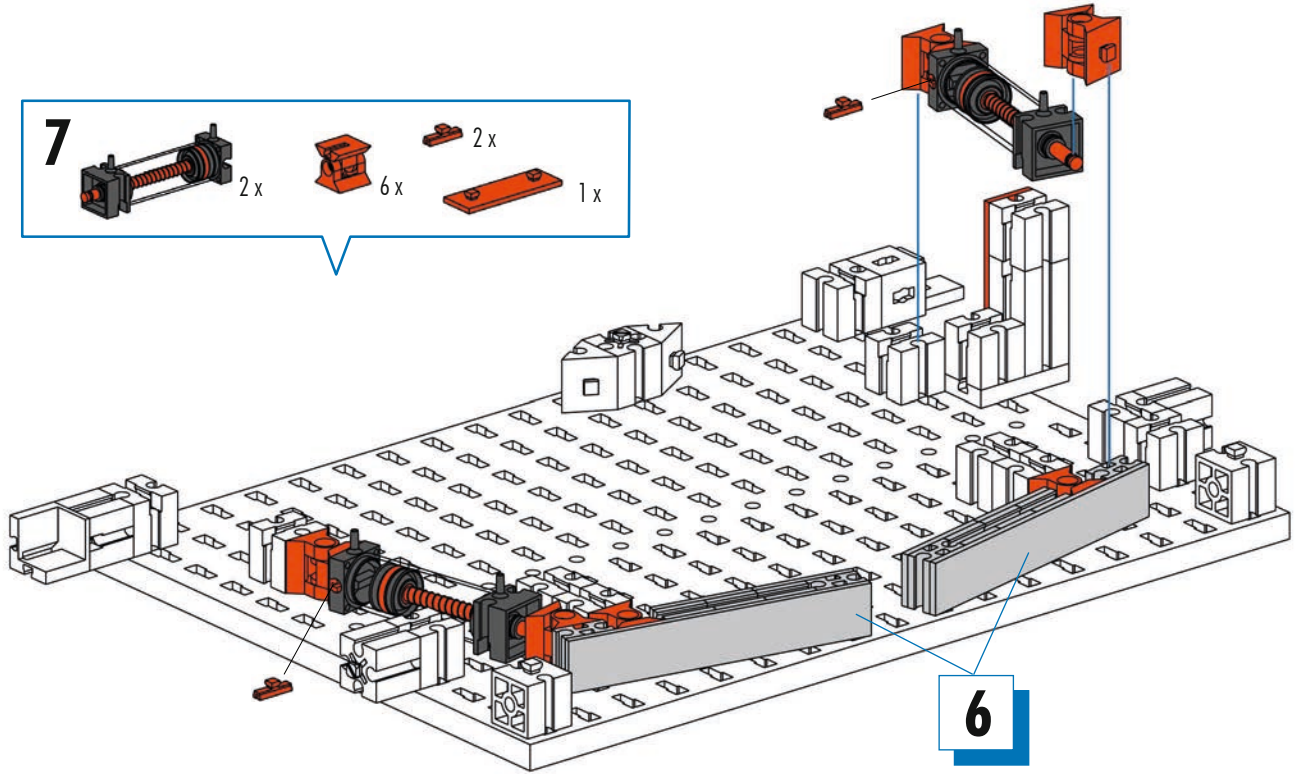
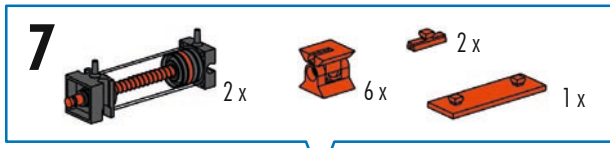

- 11**
- 3 x
 - 3 x
 - 2 x
 - 1 x
 - 1 x
 - 4 x

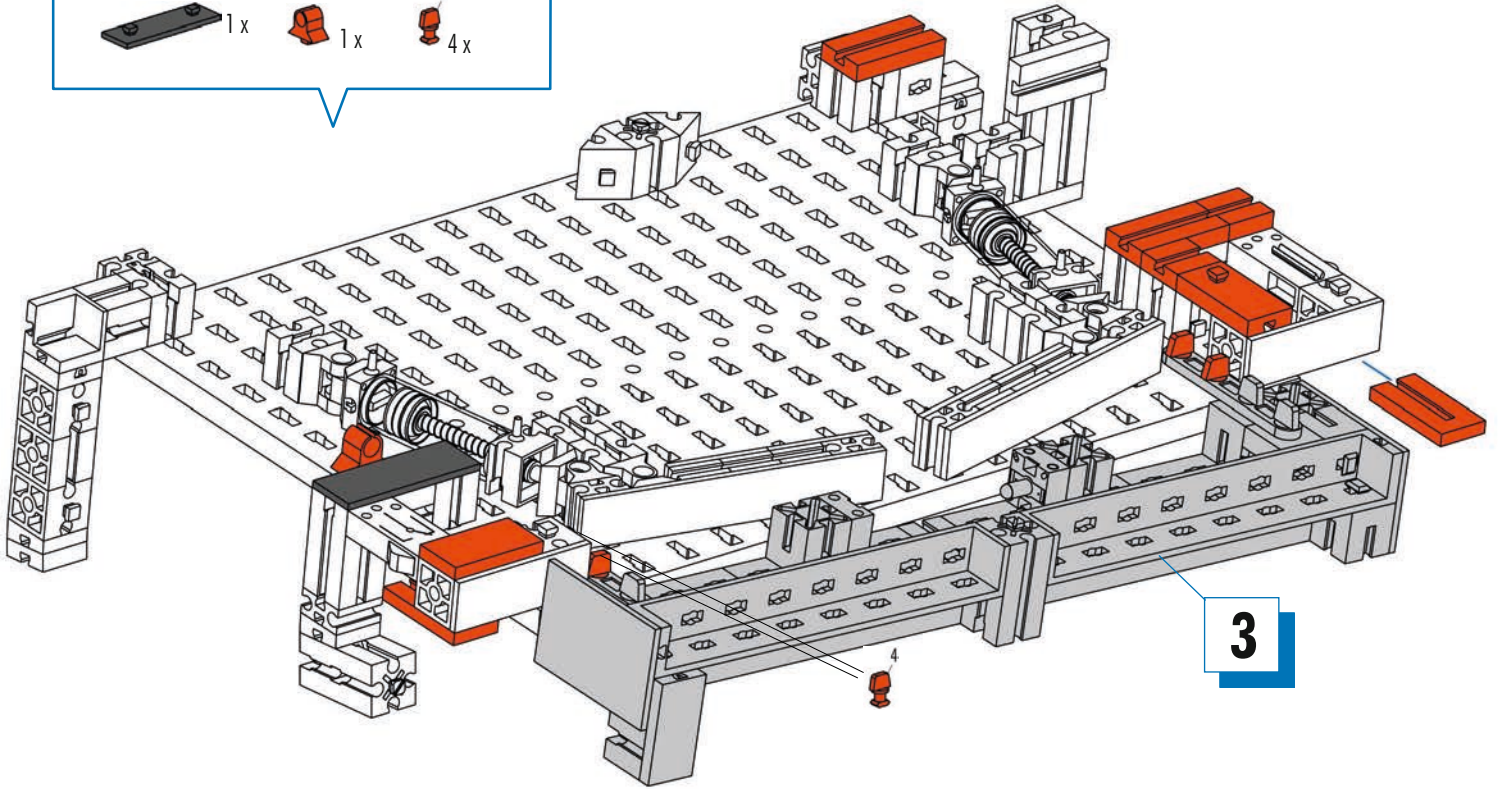

- 12**
- 1 x
 - 1 x
 - 5 x
 - 2 x
 - 1 x
 - 1 x
 - 1 x

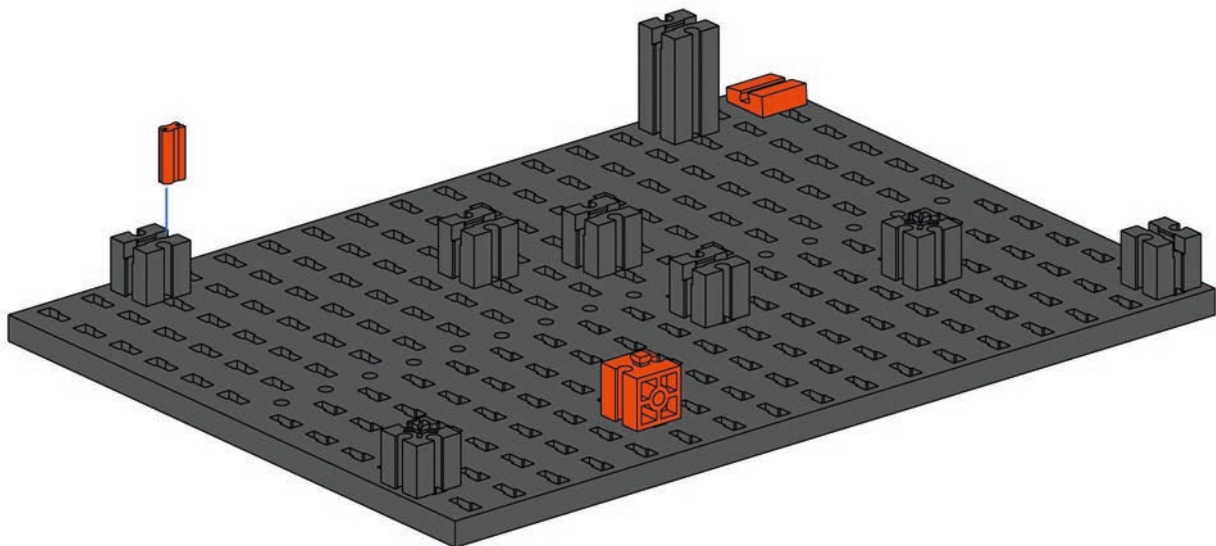

13

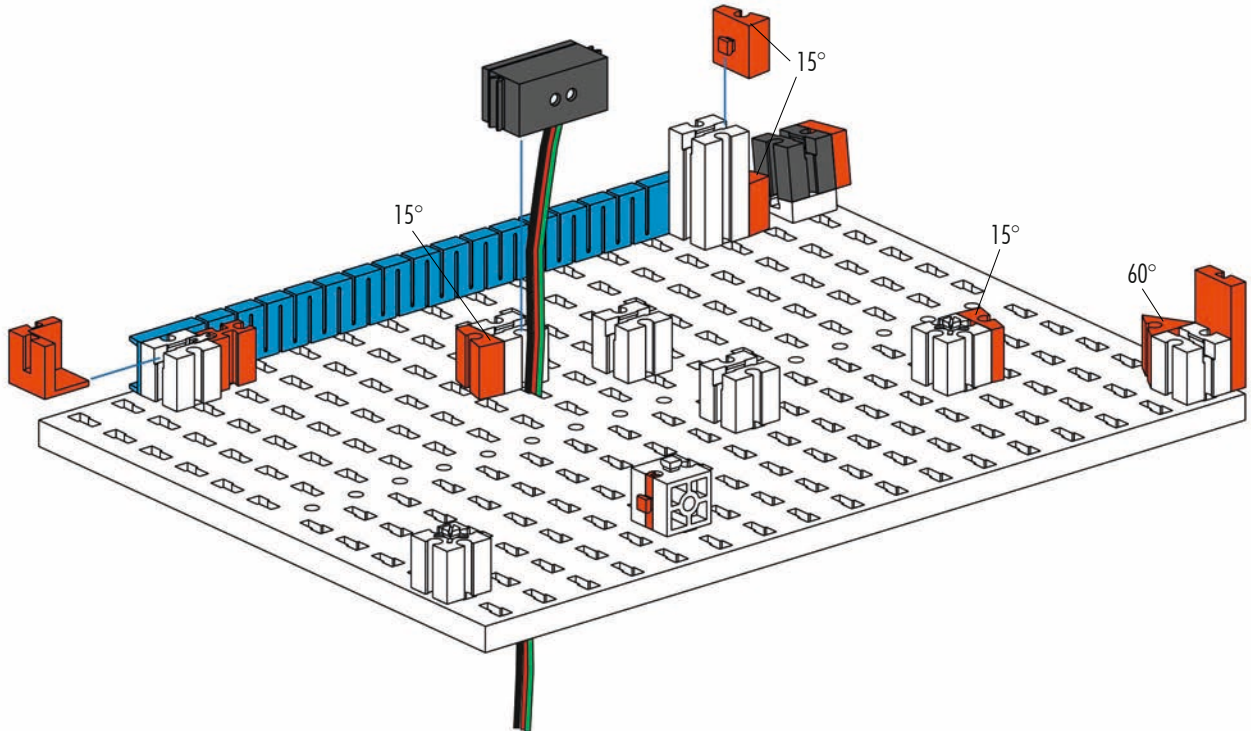
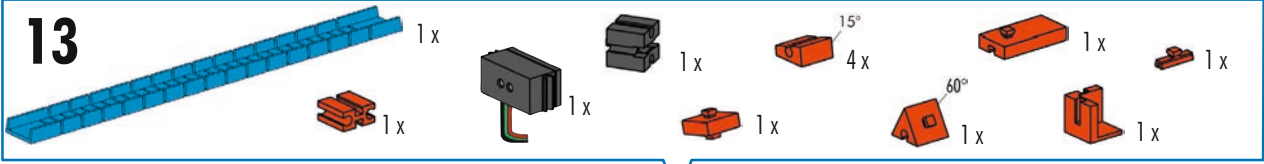

14

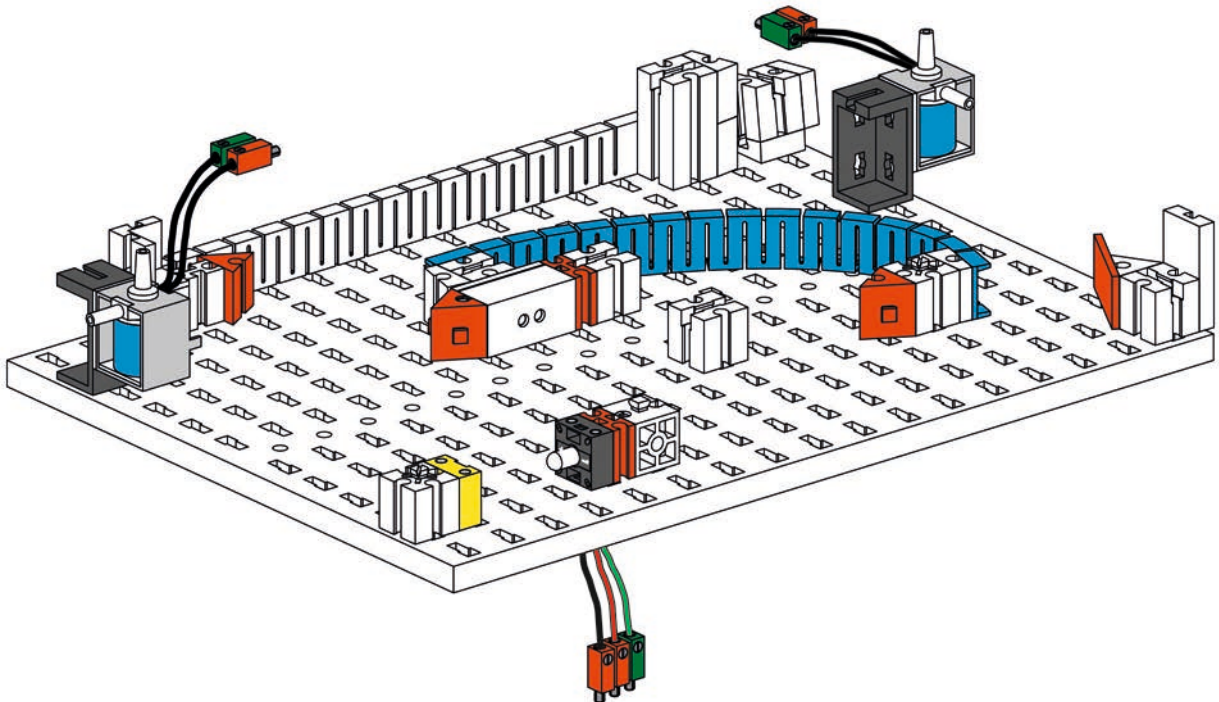
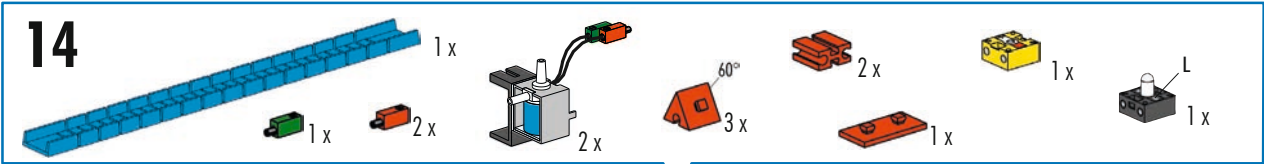

15

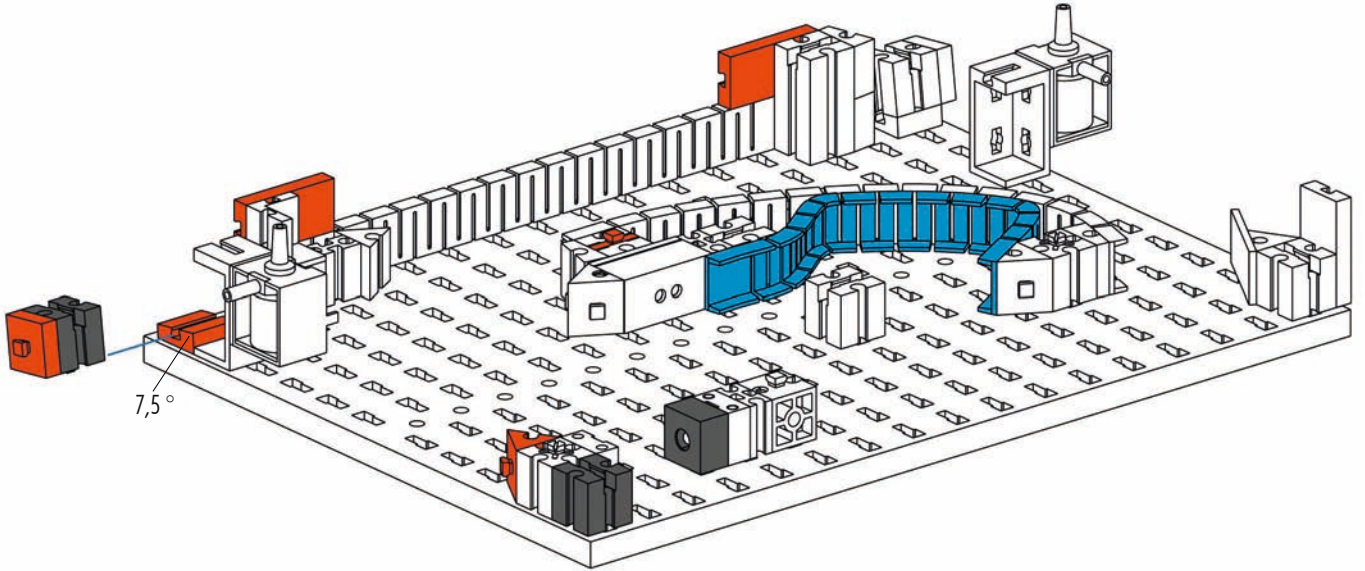
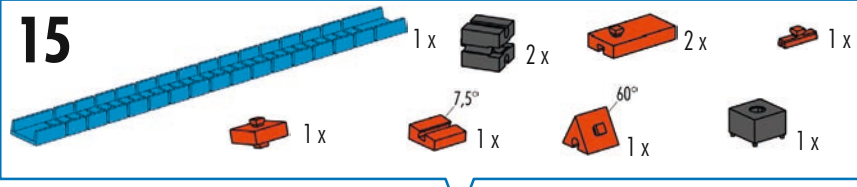

16

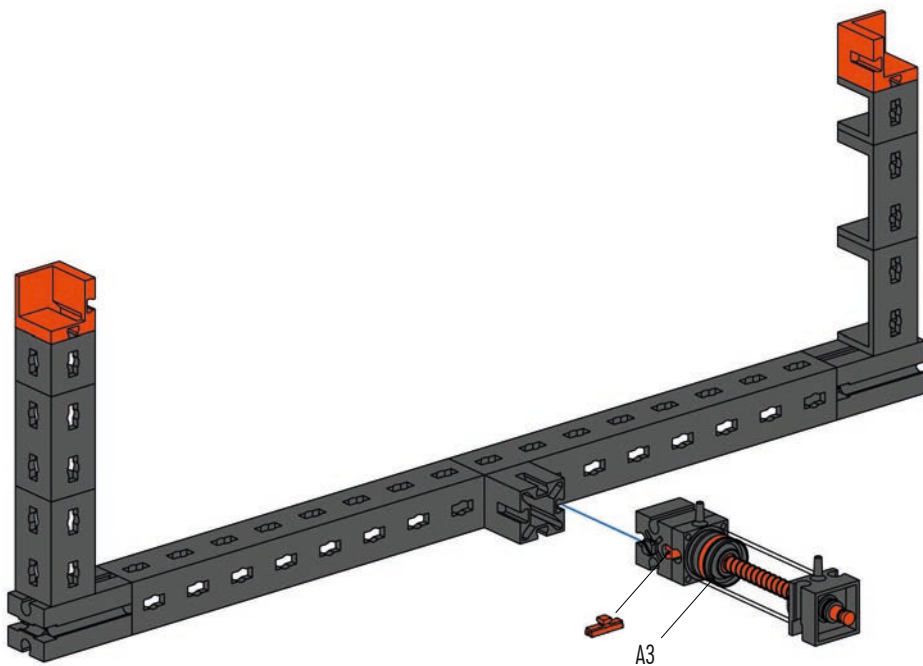
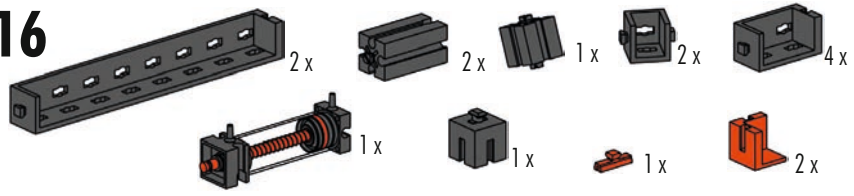

17

- 1 x (Blue Technic Beam 1x15)
- 6 x (Orange Technic Brick 1x3)
- 1 x (Orange Technic Brick 1x2)
- 2 x (Orange Technic Brick 1x3 with 30° angle)
- 2 x (Orange Technic Brick 1x3 with 60° angle)

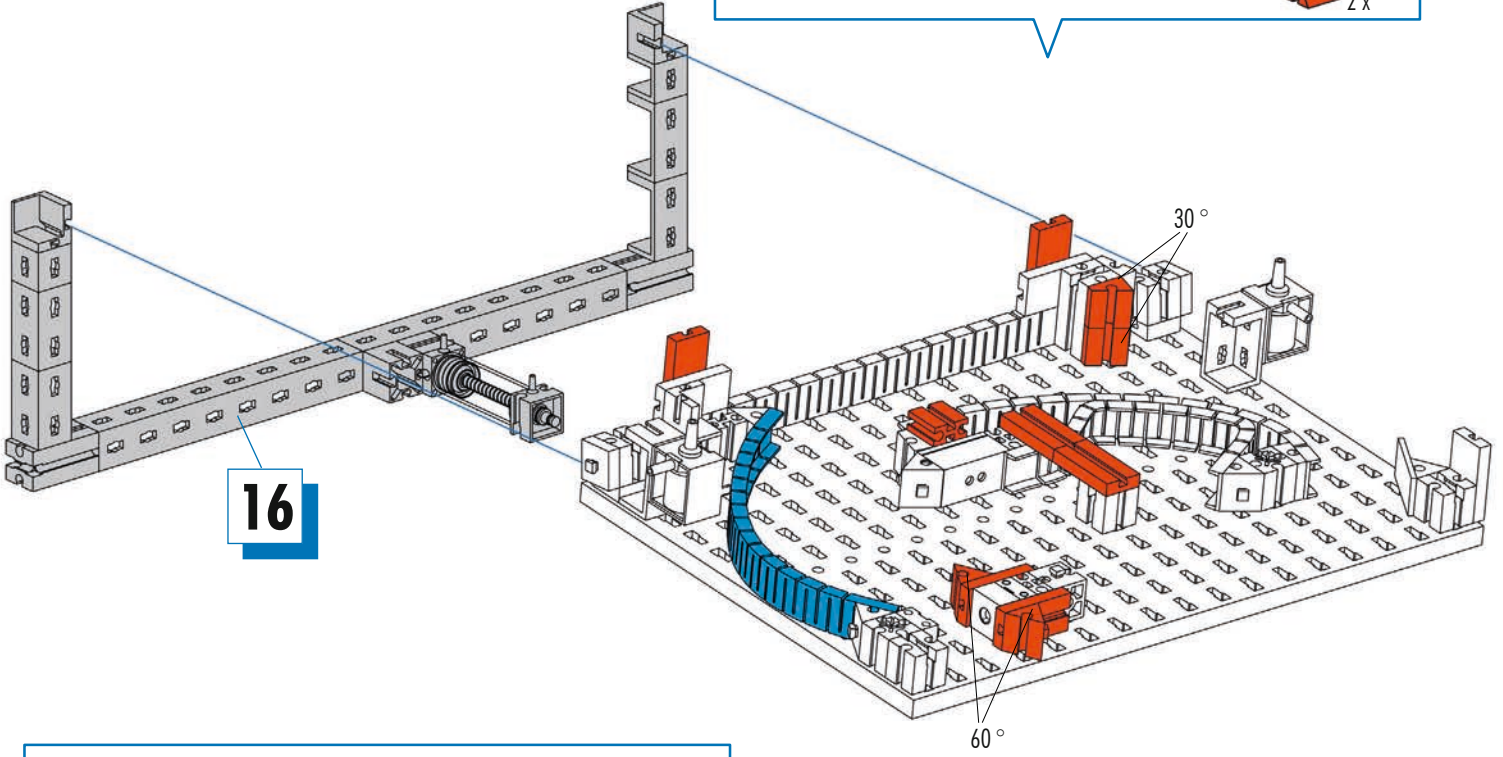

16

18

- 2 x (Blue Technic Beam 1x15)
- 2 x (Orange Technic Brick 1x3)
- 1 x (Orange Technic Brick 1x2)
- 2 x (Orange Technic Brick 1x3)
- 2 x (Orange Technic Brick 1x3)
- 1 x (Orange Technic Brick 1x3 with 15° angle)
- 1 x (Orange Technic Brick 1x3 with 30° angle)

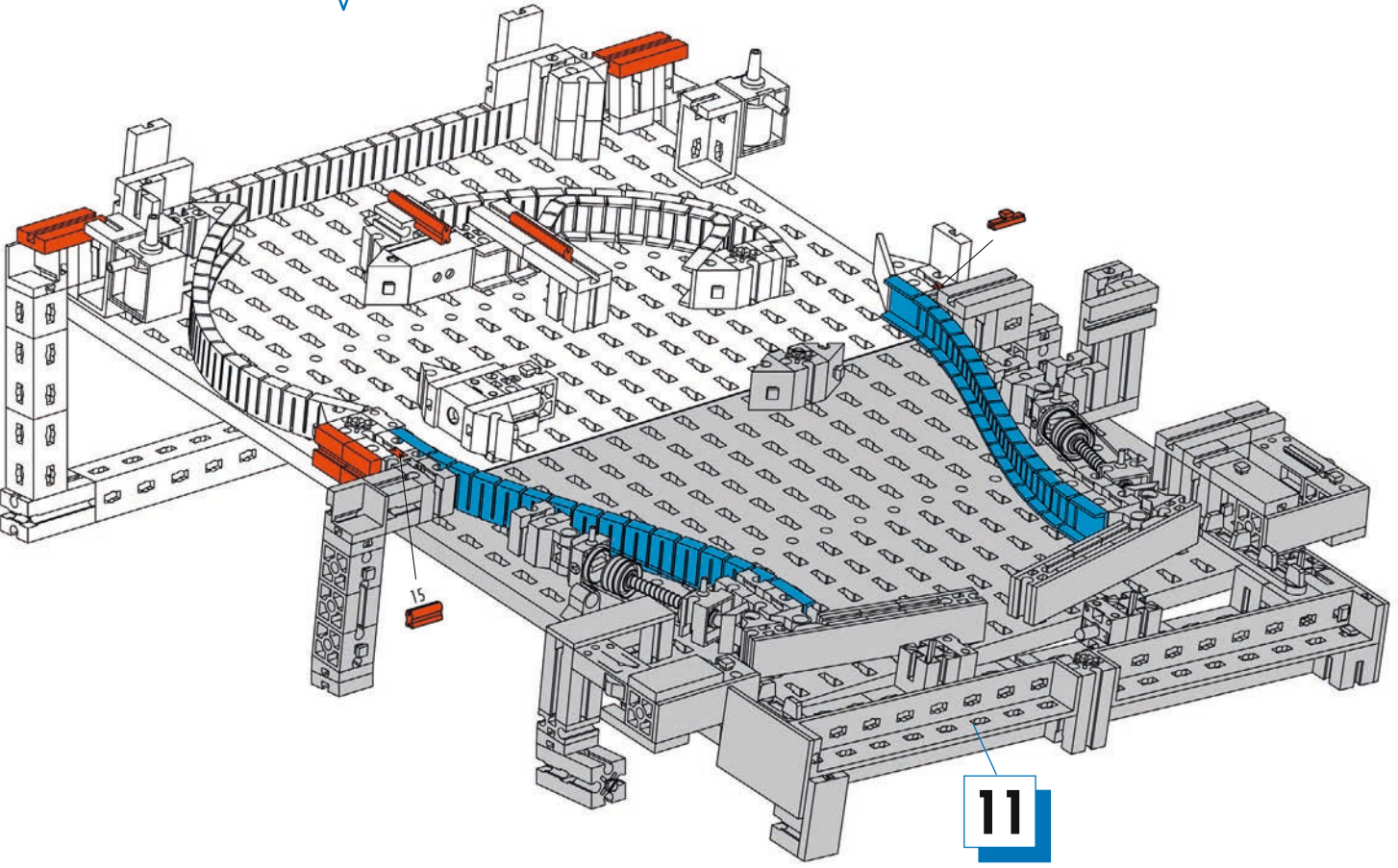

11

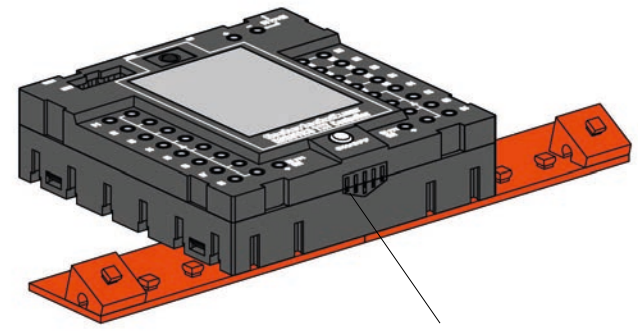
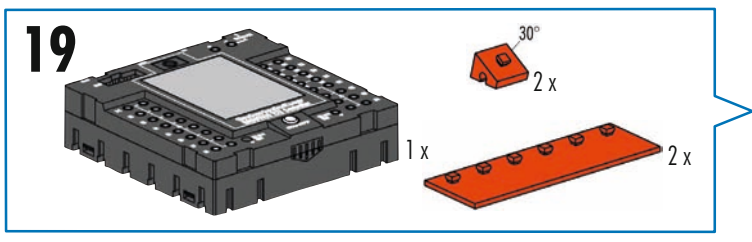

- ROBO TXT Controller (Art.-Nr. 522429) nicht im Baukasten enthalten
- ROBO TXT Controller (Art.-Nr. 522429) not included in the modular kit
- ROBO TXT Controller (Art.-Nr. 522429) n'est pas contenue dans le kit
- ROBO TXT Controller (Art.-Nr. 522429) niet in de bouwdoos opgenomen
- ROBO TXT Controller (Art.-Nr. 522429) no está incluido en el conjunto
- ROBO TXT Controller (Art.-Nr. 522429) não contido no sistema de construção por blocos
- ROBO TXT Controller (Art.-Nr. 522429) non incluso nella scatola di montaggio
- ROBO TXT Controller (Art.-Nr. 522429) не входит в комплект конструктора
- ROBO TXT Controller (Art.-Nr. 522429) 不包含在组件

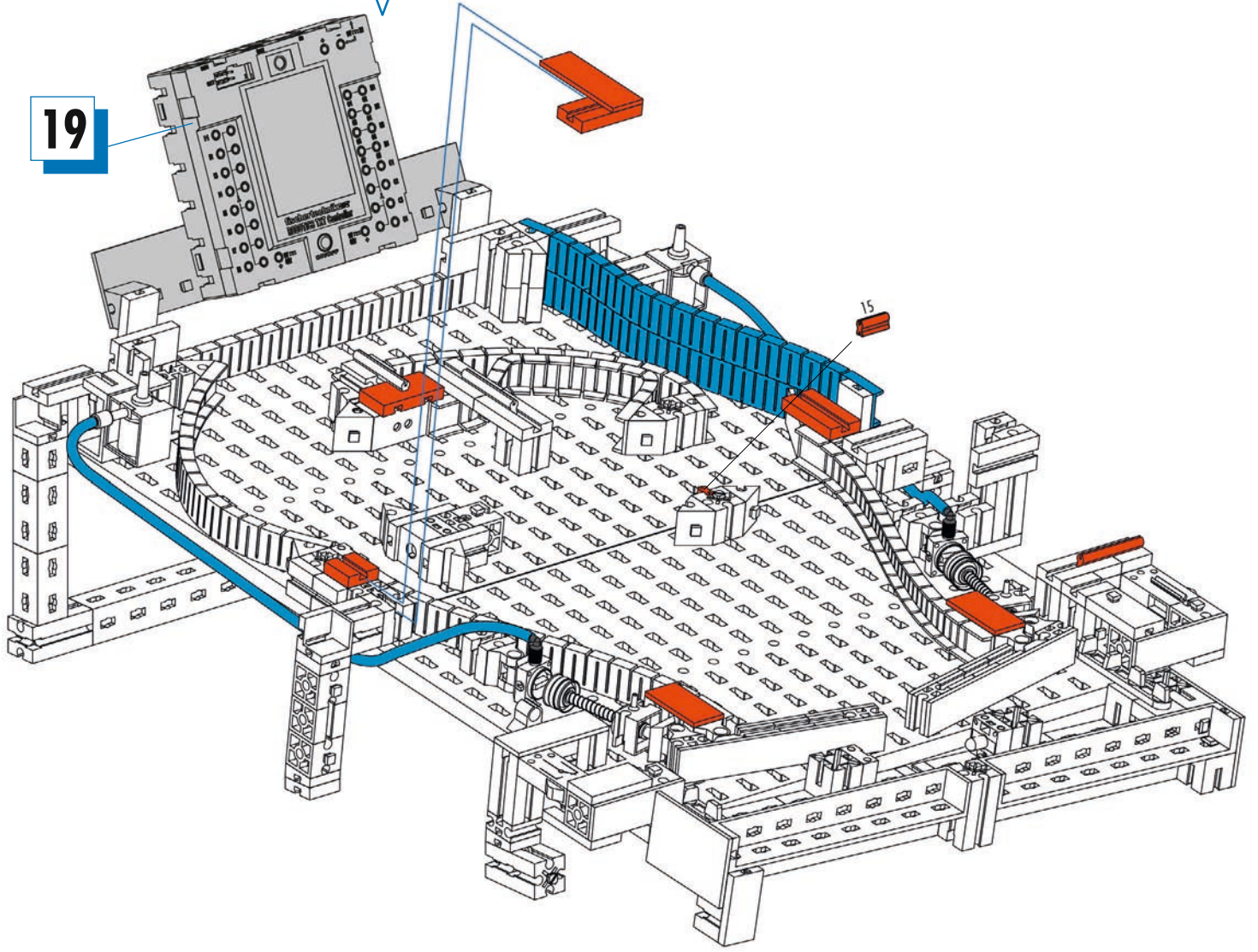
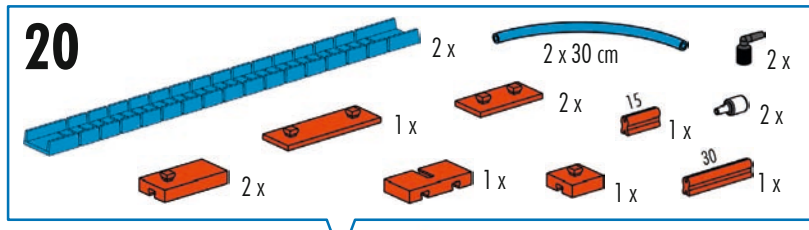

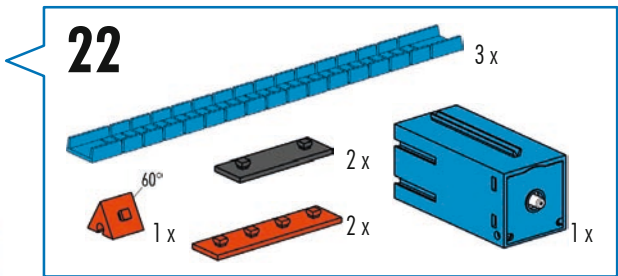
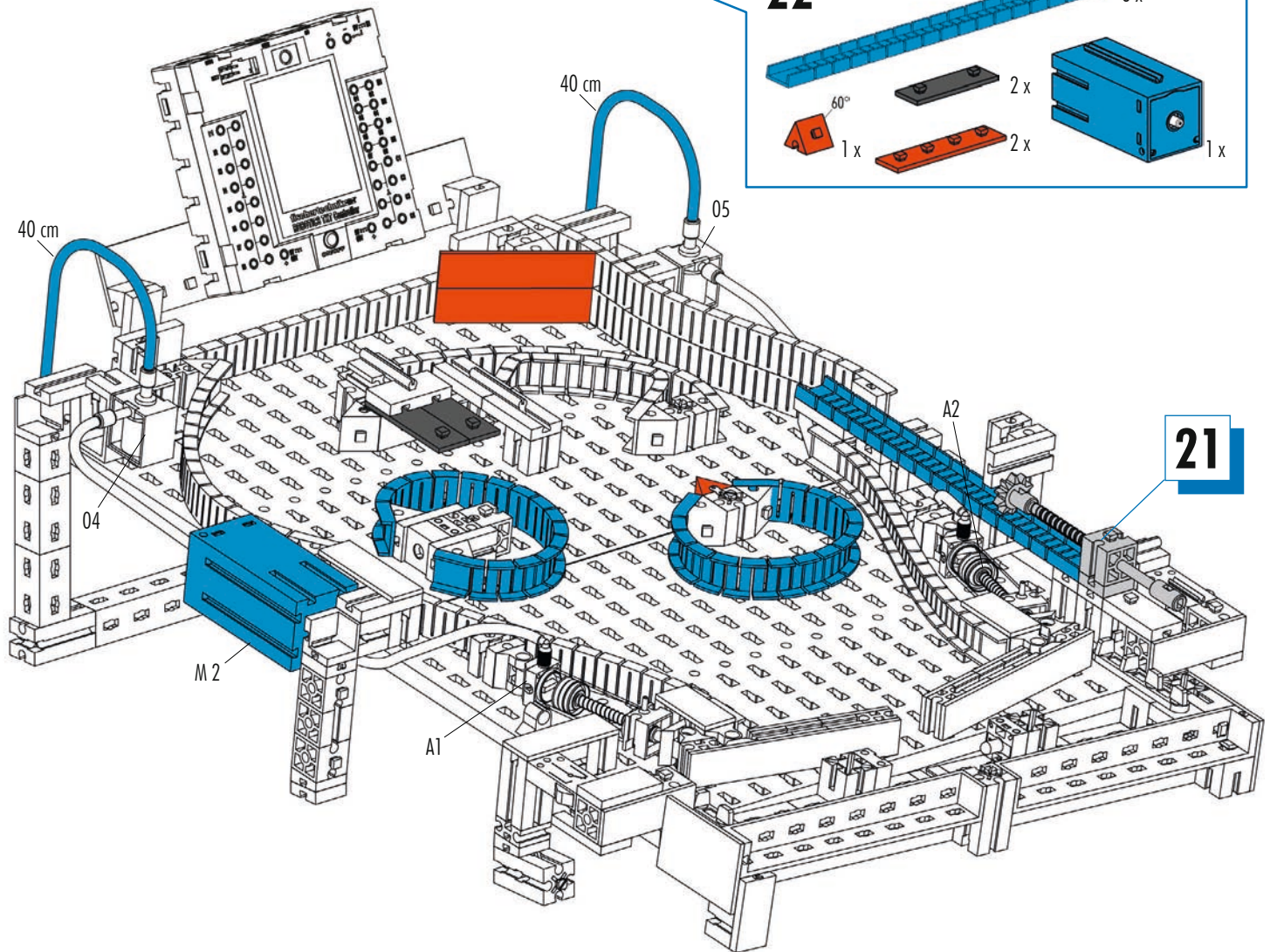
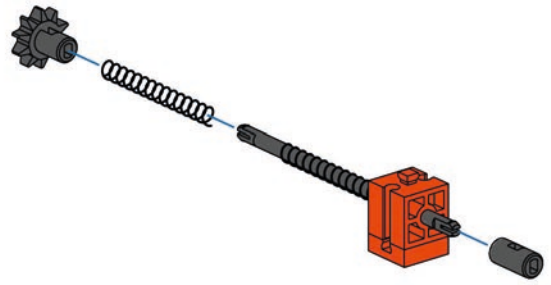
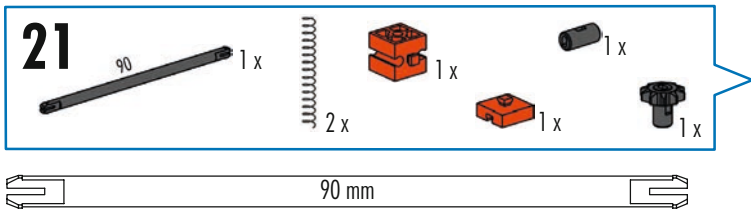

21

- Informationen zur Programmierung des Modells: Siehe didaktisches Begleitmaterial.
- Information on programming model: See related instructional material.
- Informations concernant la programmation de la maquette : voir le matériel d'accompagnement didactique.
- Informatie over de programmering van het model: Zie het didactisch begeleidend materiaal.
- Informaciones sobre la programación del modelo: Véase material didáctico.
- Informações sobre a programação do modelo: ver o material didático de acompanhamento.
- Informazioni sulla programmazione del modello: vedi materiale didattico.
- Информация о программировании модели: смотрите обучающий сопроводительный материал.
- 有关该模型编程的信息：见指导性说明资料。

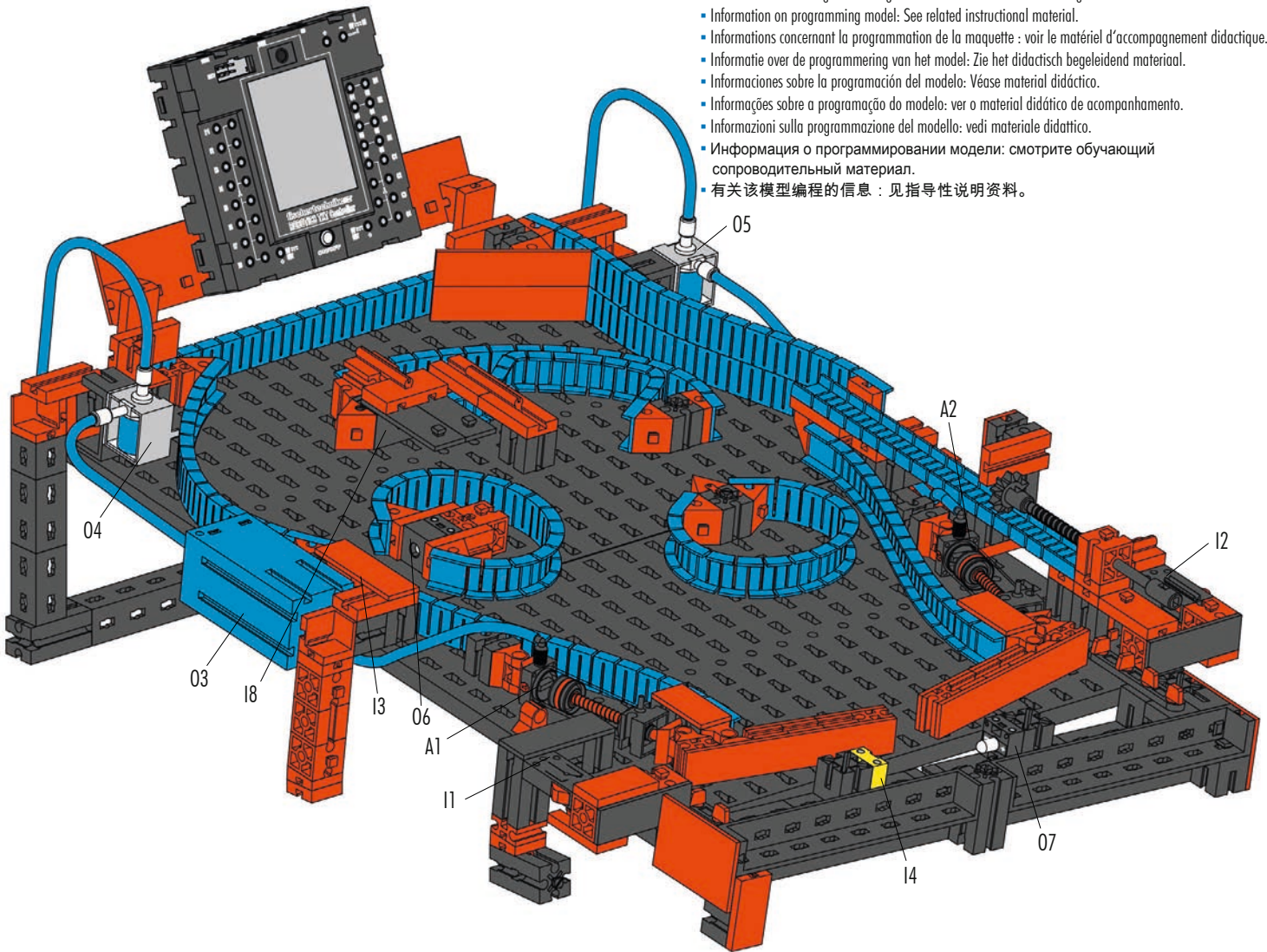

Schaltplan
Circuit diagram
Plan électrique

Schakelschema
Diagrama de circuitos
Plano eléctrico de ligação

Schema elettrico
Схема подключения
电路图

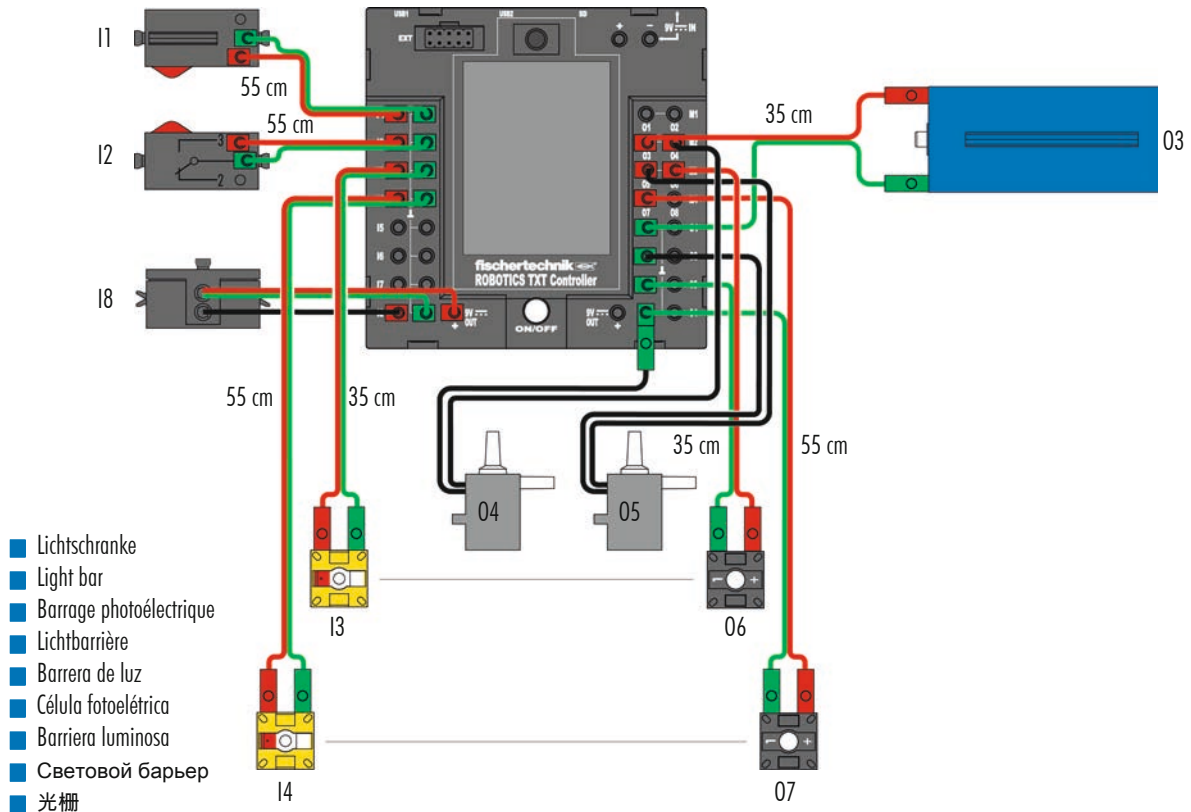

Schlauchanschlussplan
Air line layout plan
Plan de raccordement de conduits

Aansluitschema van slang
Racor de empalme
Plano de conexão de mangueira

Schema di allacciamento tubi
Схема подключения шлангов
软管连接图

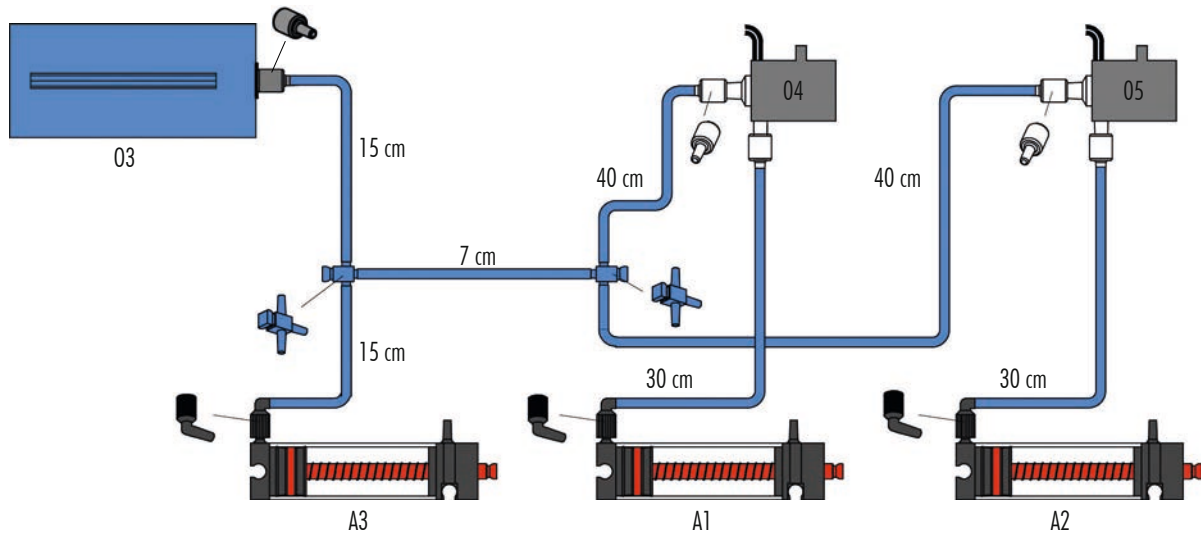

Empfohlene Aufbewahrung:	4 x Aufbewahrungssystem Art.-Nr. 94828
Recommended storage:	4 x storage system Art No. 94828
Stockage conseillé :	4 x système de stockage Art n° 94828
Bewaaradvies:	4 x bewaarsysteem art.-nr. 94828
Consejos para guardar el producto:	4 x almacenamiento Art. N° 94828
Conservação recomendada:	4 x sistema de conservação n.º de art. 94828
Conservazione consigliata:	4 sistemi di conservazione, cod. prod. 94828
Рекомендуемое хранение:	4 x бокса для хранения. Арт.№ 94 828
推荐的保存方式 :	4 个产品号为 94 828 的保存系统

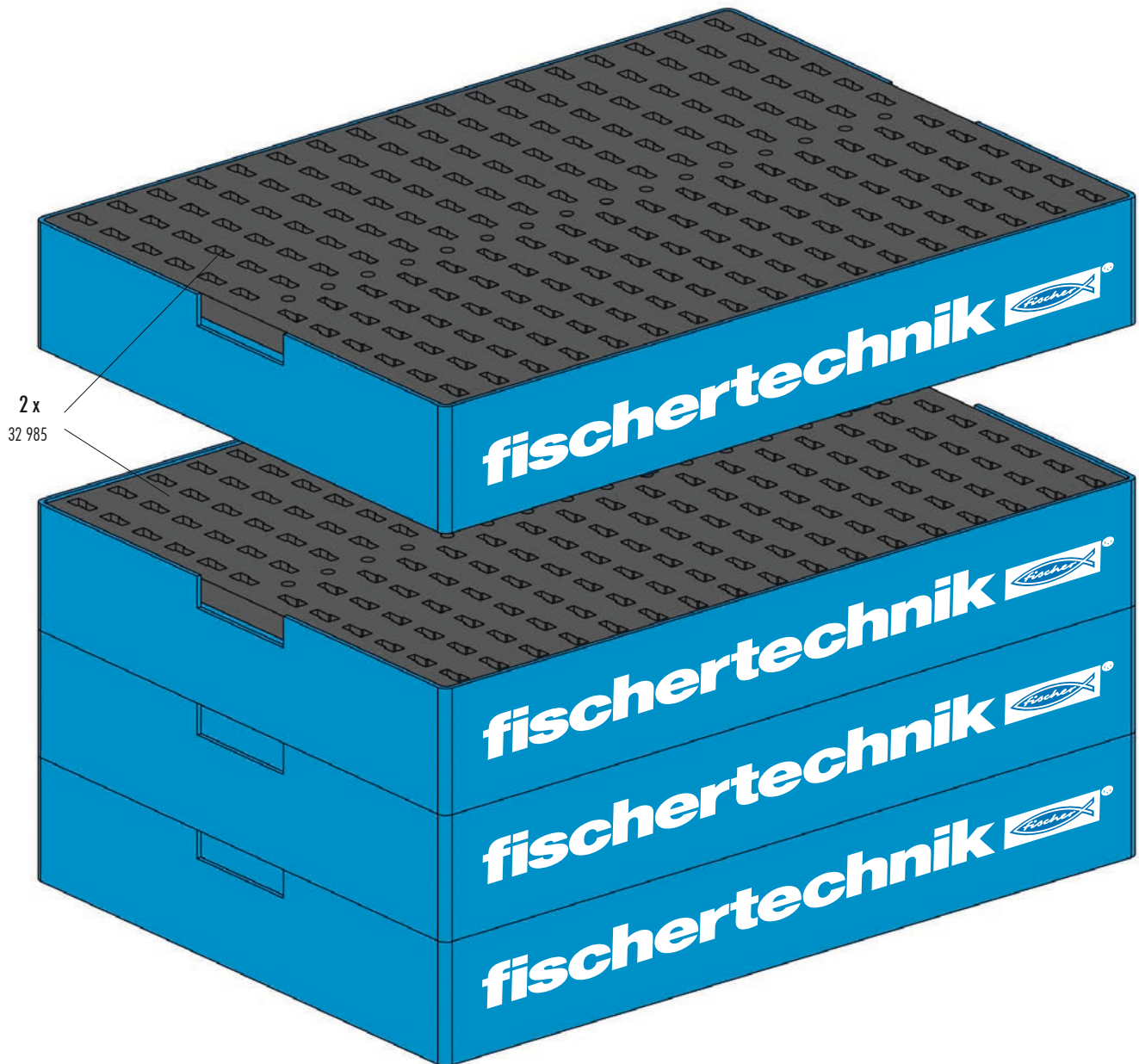

Sortiervorschlag / Storage suggestion / Suggestion de classement / Sorteervoorstel / Propuesta de clasificación / Proposta de divisão / Proposta di sistemazione / Рекомендации по сортировке / 保存系统的分类建议:

www.fischertechnik.de/Sortiervorschläge



Hinweise zum Umweltschutz / Instructions for Environmental Protection / Remarques de protection de l'environnement / Bescherming van het milieu / Notas con respecto a la protección del medio ambiente / Instruções para a proteção do meio ambiente / Indicazioni sulla tutela ambientale / Указания по охране окружающей среды / 有关环保的提示 :

www.fischertechnik.de/environment

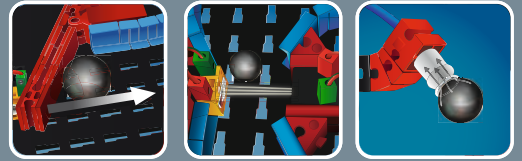

fischertechnik 

ROBOTICS

fischertechnik GmbH
Klaus-Fischer-Str. 1
72178 Waldachtal
Germany
Phone: +49 74 43/12-43 69
Fax: +49 74 43/12-45 91
info@fischertechnik.de
www.fischertechnik.de

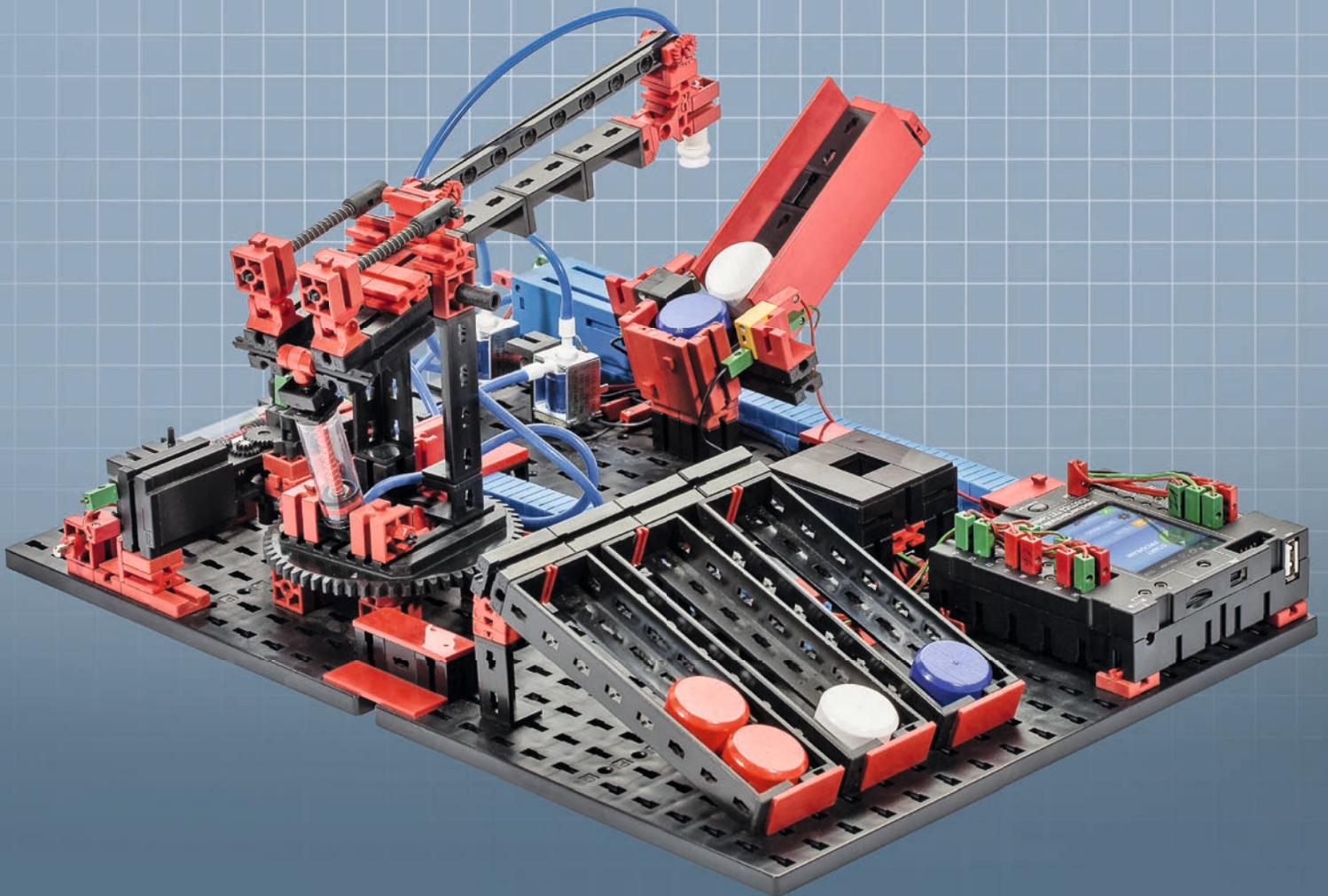

121936 · 02/22 · A · Co · Printed in Germany · Technische Änderungen vorbehalten · Subject to technical modifications

TXT *ElectroPneumatic* **4 MODELS**
Robotics & Electropneumatics