

fischertechnik 

Bauanleitung
Assembly instruction
Instructions de montage
Bouwhandleiding
Instrucciones de construcción
Manual de montagem
Istruzioni di montaggio
Инструкция по сборке
安装说明书

3D

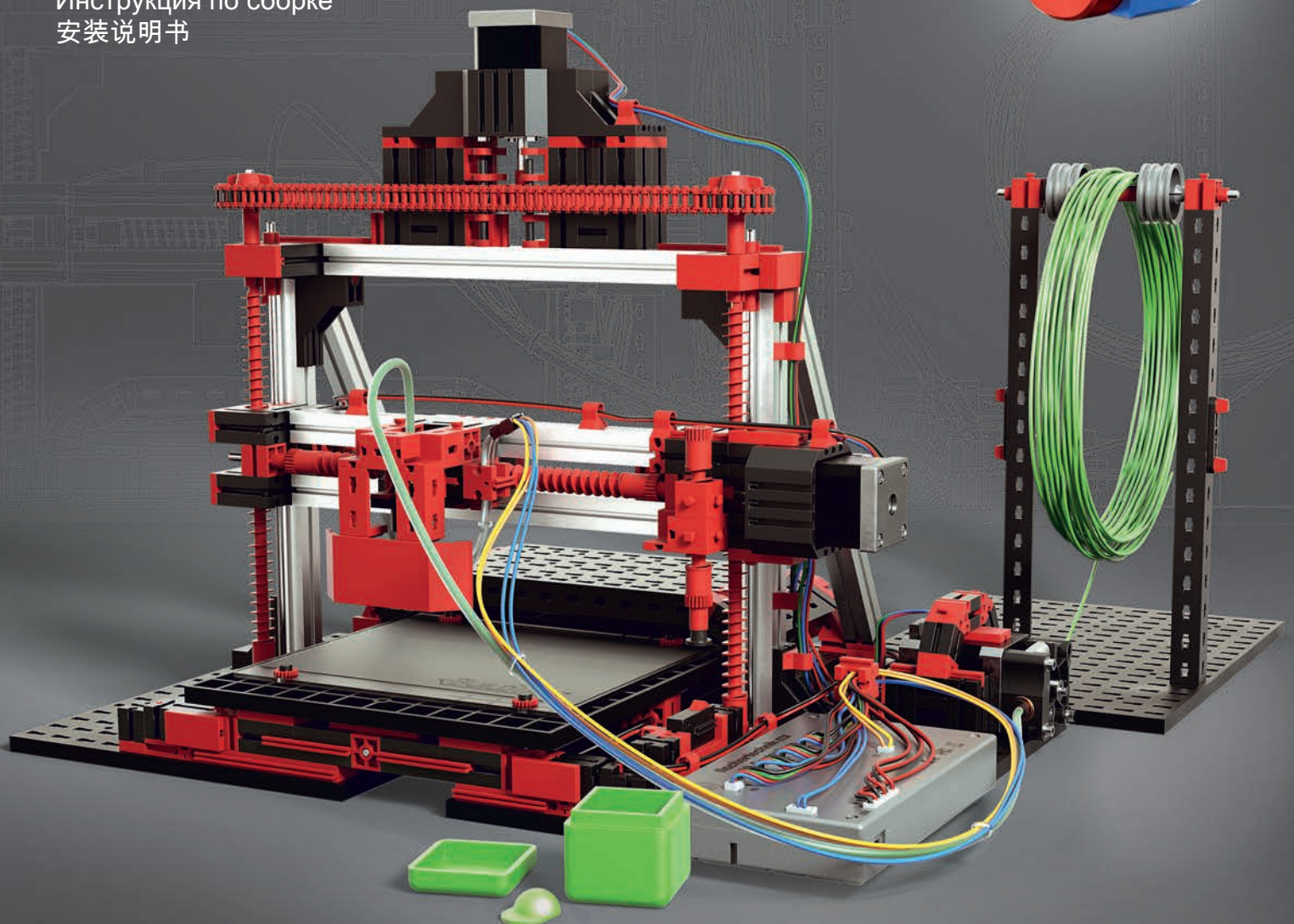

3D Printer

powered by

German
RepRap





Mit dem fischertechnik eLearning-Portal geben wir dir die Möglichkeit, noch mehr Hintergrundwissen zum Thema des Baukastens zu erhalten. Über die Eingabe des eLearning-Codes bekommst du Zugang zu didaktischen Begleitinformationen mit spannenden Versuchen, Animationen und Fotos. So macht Lernen noch mehr Spaß - garantiert! Über www.fischertechnik-elearning.com gelangst du direkt zum eLearning-Portal. Einfach auf den entsprechenden Baukasten klicken und den folgenden Code eingeben: **ft59x9**

The fischertechnik eLearning portal gives you the possibility of obtaining additional background information on the subject of the construction set. After entering the eLearning code you receive access to additional educational information with interesting experiments, animations and photographs. This makes learning fun - for sure! The eLearning portal can be reached directly at www.fischertechnik-elearning.com. Simply click on the construction set in question and enter the following code: **ft59x9**

Le portail d'apprentissage en ligne appelé eLearning de fischertechnik vous confère la possibilité d'obtenir encore plus d'informations complémentaires spécifiques aux boîtes de construction. Il suffit de saisir le code eLearning pour accéder aux informations d'accompagnement didactiques assorties d'essais captivants, d'animations et de photos. Qu'attendez-vous pour apprendre davantage en s'amusant ?

Vous accédez directement au portail de l'apprentissage en ligne en cliquant sur www.fischertechnik-elearning.com. Cliquez sur la boîte de construction qui vous intéresse et saisissez le code : **ft59x9**

Met het fischertechnik eLearning-portal bieden wij jou de mogelijkheid om nog meer achtergrondkennis over het onderwerp van de bouwdoos op te doen. Door het invoeren van de eLearning-code krijg je toegang tot leerzame informatie met spannende testen, animaties en foto's. Zo is leren gegarandeerd nog leuker! Via www.fischertechnik-elearning.com ga je direct naar het eLearning-portal. Klik simpelweg op de desbetreffende bouwdoos en voer de volgende code in: **ft59x9**

Con el portal eLearning de fischertechnik te ofrecemos la posibilidad de adquirir mayores conocimientos sobre el tema del kit de construcción. Introduciendo el código de eLearning obtendrás información didáctica adicional con interesantes experimentos, animaciones y fotos. Así, aprender será mucho más divertido. En www.fischertechnik-elearning.com accedes directamente al portal de eLearning. Solo debes hacer clic en el kit de construcción correspondiente e introducir el siguiente código: **ft59x9**

Com o portal eLearning da fischertechnik, oferecemos a você a possibilidade de obter ainda mais conhecimentos básicos sobre o tema dos módulos. Ao digitar o código de eLearning, você vai acessar informações didáticas adicionais, com experimentos empolgantes, animações e fotos. Assim, aprender se torna muito mais divertido! Através do site www.fischertechnik-elearning.com você acessa diretamente o portal eLearning. Basta clicar no módulo correspondente e inserir o seguinte código: **ft59x9**

Con il portale di e-learning di fischertechnik hai la possibilità di approfondire ulteriormente gli argomenti del set di costruzione. Immettendo il codice per l'e-learning, potrai accedere alle informazioni didattiche con fantastici esperimenti, animazioni e foto. Imparare sarà ancora più divertente, te lo garantiamo! Per accedere al portale di e-learning basta visitare la pagina www.fischertechnik-elearning.com. Quindi fai clic sul set di costruzione corrispondente e immetti il seguente codice: **ft59x9**

Портал eLearning даёт тебе возможность получить ещё больше знаний по теме набора fischertechnik. Введи код eLearning, и ты получишь доступ к обучающей сопроводительной информации с увлекательными опытами, анимациями и фотографиями. Так обучение доставит ещё больше удовольствия - мы гарантируем это! Через www.fischertechnik-elearning.com ты попадёшь прямо на портал eLearning. Просто щёлкни по соответствующему набору и введи следующий код: **ft59x9**

通过慧鱼 (fischertechnik) 网络学习门户，你能够获得更多与标准构件相关的背景知识。输入网络学习代码你就能获得指导性的安装信息，且配有引人入胜的实验、动画和图片。所以保证学起来更有兴趣！通过 www.fischertechnik-elearning.com 直接进入网络学习门户。点击相应的标准构件，并输入以下代码：**ft59x9**

Inhalt
Contents
Contenu

Inhoud
Contenido
Conteúdo

Contenuto
Содержание
目录

Einzelteilübersicht / Spare parts list / Liste des pièces détachées / Onderdelenoverzicht / Lista da piezas / Resumo de peça individual /
Singoli componenti / Перечень деталей / 零件概览 2

Sicherheitshinweise / Safety Information / Consignes de sécurité / Veiligheidsrichtlijnen / Indicaciones de seguridad / Observações sobre segurança /
Informazioni per la sicurezza / Указания по технике безопасности / 安全指南 3

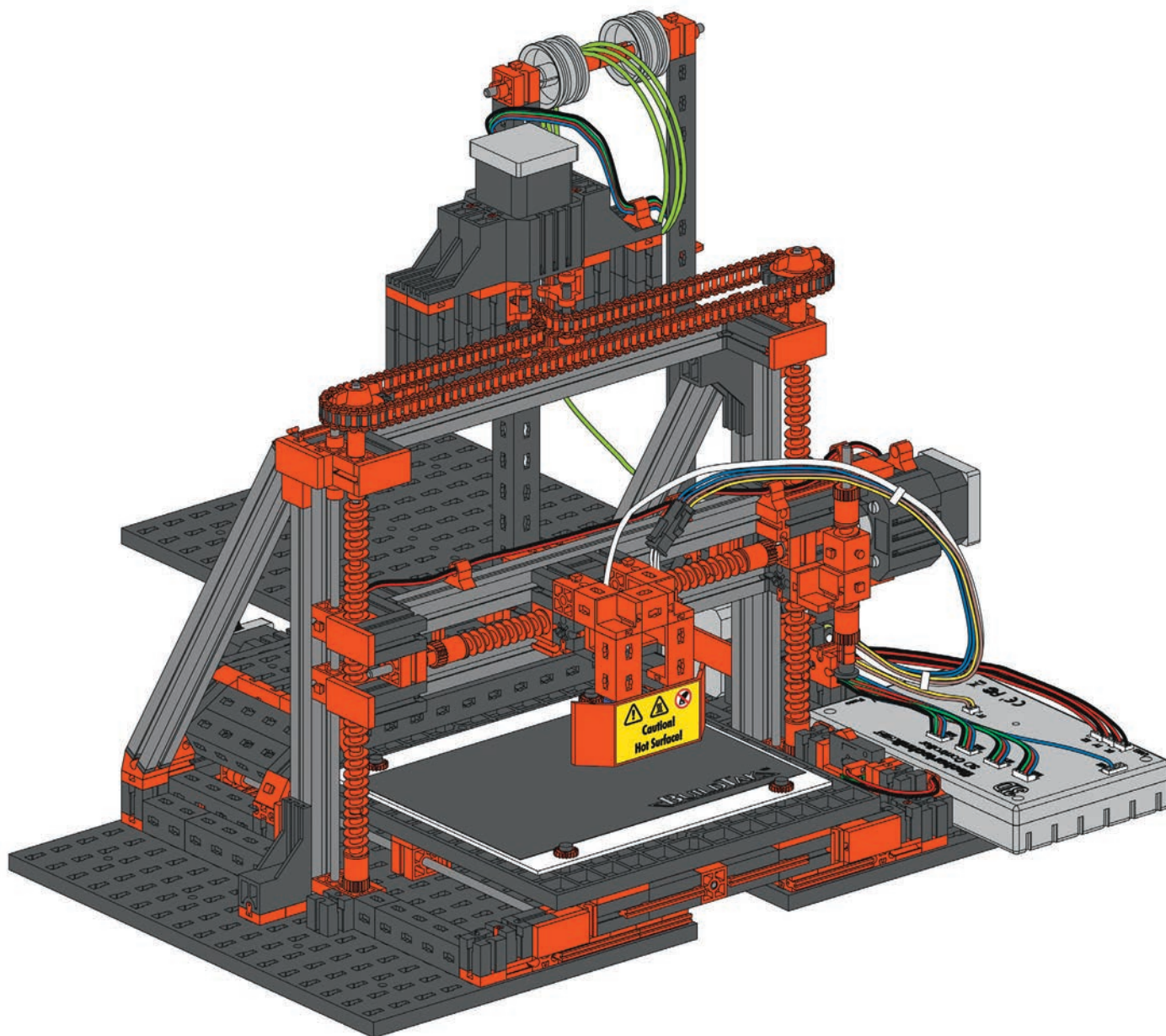

3D Printer 11

Halterung Filamentspule / Filament spool holder / Support de la bobine de filament / Houder filamentspoel / Soporte para bobinas de filamento / Suporte da bobina
de filamento / Supporto bobina del filamento / Держатель катушки филамента / 打印线材盘卷支架 43



























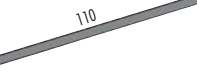









































EU Konformitätserklärung / EC Declaration of Conformity / EU Declaration de Conformité / EU verklaring van Overeenstemming / CE-Declaración de Conformidad / UE declaração de
conformidade / UE Dichiarazione di conformità:

















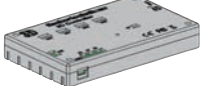

<http://www.fischertechnik.de/home/downloads/3D-Printer.aspx>

Einzelteilübersicht
Spare parts list
Liste des pièces détachées

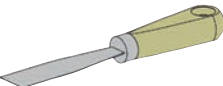
Onderdelenoverzicht
Lista da piezas
Resumo de peça individual

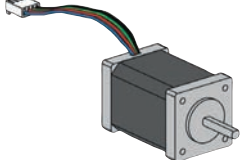
Singoli componenti
Перечень деталей
零件概览

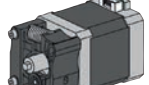
	10 497 3 x		31 983 4 x		36 293 5 x		37 925 10 x
	31 010 8 x		32 064 28 x		36 323 4 x		37 926 20 x
	31 011 10 x		32 085 4 x		36 334 14 x		38 240 9 x
	31 021 2 x		32 316 8 x		36 443 1 x		38 244 1 x
	31 031 1 x		32 330 14 x		36 573 2 x		38 414 2 x
	31 036 1 x		32 615 10 x		36 593 1 x		38 423 5 x
	31 058 2 x		32 854 3 x		36 912 2 x		38 428 6 x
	31 060 24 x		32 879 58 x		36 920 4 x		107 436 4 x
	31 061 22 x		32 881 45 x		36 921 9 x		116 913 2 x
	31 226 7 x		32 882 16 x		36 922 2 x		124 802 10 x
	31 330 38 x		32 913 2 x		36 950 5 x		127 471 2 x
	31 336 3 x		32 985 4 x		37 237 42 x		127 472 4 x
	31 337 3 x		35 031 2 x		37 468 48 x		139 645 1 x
	31 597 8 x		35 049 12 x		37 636 2 x		159 576 2 x
	31 896 1 x		35 969 16 x		37 679 31 x		159 577 1 x
	31 915 7 x		36 132 1 x		37 783 3 x		159 590 2 x
	31 982 86 x		36 248 138 x		37 858 7 x		160 528 3 x

	160 540 1 x		160 840 1 x		160 843 12 x		161 260 1 x
	160 549 2 x				161 252 1 x		161 261 10 x
	160 550 1 x		160 841 1 x		161 253 1 x		539 121 1 x
	160 670 1 x				161 254 1 x		161 837 1 x
	160 838 1 x		160 842 3 x		161 255 1 x		
	160 839 1 x				161 257 1 x		

Sicherheitshinweise
Safety Information
Consignes de sécurité

Veiligheidsrichtlijnen
Indicaciones de seguridad
Observações sobre segurança

Informazioni per la sicurezza
Указания по технике безопасности
安全指南

- Alle Einzelteile, insbesondere bewegliche Teile sind falls notwendig zu warten und zu reinigen.
- All components, especially moving parts, should be maintained and cleaned as necessary.
- Toutes les pièces détachées et en particulier les pièces mobiles, sont, si nécessaire, à entretenir et à nettoyer.
- Alle onderdelen, vooral de bewegende delen, kunnen, indien noodzakelijk, onderhouden en gereinigd worden.
- Es necesario limpiar y mantener en buen estado todas las diferentes piezas - especialmente las piezas móviles.
- Caso necessário, todas as peças individuais, especialmente peças móveis, tem que ser submetidas à manutenção e ser limpadas.
- Se necessario, tutti i singoli componenti, soprattutto le parti mobili, si devono eventualmente sottoporre a manutenzione e pulizia.
- Все детали, особенно подвижные, требуют ухода и чистки.
- 必要时应保养和清洁所有零件，尤指运动部件。

- Achtung! Verletzungsgefahr an Bauteilen mit funktionsbedingten scharfen Kanten und Spitzen!
- Caution! Be careful not to hurt yourself on components with sharp or pointed edges!
- Attention! Risque de blessure sur les éléments comportant des arêtes et pointes vives indispensables au bon fonctionnement!
- Let op! U kunt zich bezeren aan bouwstenen met scherpe randen of punten!
- Attenzione! Esiste il pericolo di lesione con i pezzi di costruzione che hanno bordi e punte spigolosi necessari per la funzionalità del pezzo!
- Atenção! Perigo de ferimentos em peças componentes com cantos vivos e pontas obrigatórias para o funcionamento!
- Attenzione! Pericolo di lesioni dovute a componenti con spigoli vivi e punte per motivi funzionali!
- Будьте осторожны! Об острые края деталей и и наконечники можно порезаться!
- 注意！因功能需要而带有锋利的棱边和尖角的部件可能会带来受伤危险！

 Hinweise zum Umweltschutz / Instructions for Environmental Protection / Remarques de protection de l'environnement / Bescherming van het milieu / Notas con respecto a la protección del medio ambiente / Instruções para a proteção do meio ambiente / Indicazioni sulla tutela ambientale / Указания по охране окружающей среды / 有关环保的提示：

www.fischertechnik.de/environment

D Weitere Sicherheitshinweise

Bestimmungsgemäße Verwendung

Der fischertechnik 3D-Drucker ist kein Spielzeug und für Jugendliche ab 14 Jahren ausschließlich dafür geeignet 3-D-Objekte aus fischertechnik Premium Filament auszudrucken.

Betriebsbedingungen

Für den Betrieb Ihres fischertechnik 3D-Drucker ist ein kühler und gut belüfteter Raum am besten geeignet! Betreiben Sie den Drucker nur im komplett montierten Zustand!

Extruder / Druckdüse

Achten Sie darauf, dass sich der Extruder sowie die Druckdüse bis zu 250° (480°F) aufheizen können. Bei unsachgemäßem Umgang sowie Berührung dieser Teile, können schwere Verbrennungen entstehen!. Bitte lassen Sie aus diesem Grund immer die Schutzabdeckung vor dem Extruder und der Druckdüse.

Bewegliche Teile

Achten Sie darauf, dass bei Betrieb des 3D-Druckers genügend Abstand eingehalten wird und sich keine Bekleidung oder Haare im Gerät verfangen. Außerdem dürfen Sie bei Betrieb nicht in den Druckraum (Druckbett, Materialzufuhr, X-/Y-/Z-Achse etc.) greifen.

Vorsicht Verletzungsgefahr! Betreiben Sie den 3D-Drucker nie ohne die vorgesehenen Schutzabdeckungen.

Filament

Das fischertechnik PLA-Filament wurde speziell für Ihren 3D-Drucker entwickelt und getestet. Dieses Filament ist separat in unterschiedlichen Farben im fischertechnik-Onlineshop erhältlich. Die Benutzung von anderen Filamenten kann zu schlechter Druckqualität oder gar Beschädigung des Druckers führen. Dies hat den Verlust der Garantie und der Gewährleistung zur Folge!

Elektrische Sicherheit

3D Printer nicht im Freien betreiben! Vor Feuchtigkeit schützen! Transformator an Ausgangsseite niemals mit anderen Transformatoren parallel schalten! Bei Beschädigung an Anschlussleitung, Stecker oder Gehäuse darf der Transformator nicht weiter benutzt werden! Überprüfung und Anschluss der Geräte liegen in der Verantwortung der Aufsichtspersonen! Anschlussklemmen dürfen nicht kurzgeschlossen werden! Der 3D Printer darf ausschließlich mit einem mitgelieferten Netzteil (19VDC/6,3A) betrieben werden.

Elektromagnetische Störungen

Sollte der 3-D-Drucker durch elektromagnetische Einflüsse gestört werden, kann er nach Ende der Störung bestimmungsgemäß weiter benutzt werden. Eventuell muss die Stromversorgung des Controllers und die USB Verbindung kurz unterbrochen und der Controller neu gestartet werden.

Gewährleistung

Die fischertechnik GmbH leistet Gewähr für die Fehlerfreiheit des Geräts entsprechend dem jeweiligen Stand der Technik. Änderungen in der Konstruktion oder Ausführung, die weder die Funktionsfähigkeit noch den Wert des Geräts beeinträchtigen, bleiben vorbehalten und berechtigen nicht zu einer Beanstandung. Offensichtliche Mängel müssen innerhalb von 14 Tagen nach Lieferung schriftlich geltend gemacht werden, ansonsten sind Gewährleistungsansprüche wegen offensichtlicher Mängel ausgeschlossen.

Wegen eines unerheblichen Mangels des Geräts bestehen keine Gewährleistungsansprüche. Im Übrigen kann der Kunde nur Nacherfüllung, d.h. Nachbesserung oder Ersatzlieferung verlangen. Der Kunde ist berechtigt, nach seiner Wahl vom Vertrag zurückzutreten oder die Minderung des Kaufpreises zu verlangen, wenn die Nacherfüllung fehlschlägt, insbesondere unmöglich ist, uns in einem angemessenen Zeitraum nicht gelingt, von uns verweigert oder von uns schuldhaft verzögert wird. Die Gewährleistung beträgt 24 Monate ab Lieferung. Für Sachmängel des Controllers, die durch unsachgemäße Handhabung, übliche Abnutzung, fehlerhafte oder nachlässige Behandlung entstehen, stehen wir ebensowenig ein, wie für die Folgen unsachgemäßer und ohne unsere Einwilligung vorgenommener Änderungen oder Instandsetzungsarbeiten des Kunden oder Dritter. Die Gewährleistung bestimmt sich nach deutschem Recht.

Haftung

Eine Haftung der fischertechnik GmbH für Schäden, die daraus resultieren, dass der 3D Printer nicht entsprechend seiner bestimmungsgemäßen Verwendung gebraucht wurde, ist ausgeschlossen.

GB Additional Safety Instructions

Intended use

The fischertechnik 3D printer is not a toy and is intended for individuals 14 years and older solely for the purpose of printing 3D objects using the fischertechnik Premium Filament.

Operating conditions

A cool, well ventilated room provides the best conditions for operating your fischertechnik 3D printer. Only operate the printer when it is fully assembled.

Extruder/printer nozzle

Please note that the extruder and the printer nozzle can be heated up to 250° (480°F). Mishandling or touching these parts can result in serious burns! For this reason, always keep the protective cover in front of the extruder and printer nozzle.

Moving parts

Make sure to maintain a sufficient distance from the operating 3D printer and that clothing or hair does not get caught in the printer. In addition, do not reach into the printing area (printing bed, material feeder, X, Y and Z axes, etc.).

Caution: risk of injury! Never operate the 3D printer without the required protective covers.

Filament

The fischertechnik PLA filament has been designed and tested specifically for your 3D printer. This filament is available separately in different colors in the fischertechnik Online Shop. The use of other filaments can result in poor printing quality or may even damage the printer. Use of other filaments will invalidate the guarantee and warranty.

Electrical safety

Do not operate the 3D printer outdoors. Protect it from moisture and humidity. Never use the transformer on the output side with other transformers at the same time. If the electrical cord, plug or housing becomes damaged, discontinue using the transformer. It is the responsibility of the person supervising the printer's use to inspect and connect the devices. Do not short-circuit the connecting terminals. The 3D printer may only be operated with the included power supply (19V DC/6.3A).

Electromagnetic interference

If the 3D printer is affected by electromagnetic influences, it can still be used for the purpose intended once the interference passes. It may be necessary to disconnect the controller power supply and the USB connection briefly and then restart the controller.

Warranty

The fischertechnik GmbH provides a warranty for the freedom from defects of the device according to the particular state of the technology. fischertechnik GmbH reserves the right to make design or model alterations which neither adversely affect the operational reliability nor the value of the device. Such changes do not entitle the customer to file a complaint. Notification of claims due to obvious defects must be provided in writing within 14 days after the delivery, otherwise any warranty claims as a result of obvious defects shall be excluded.

The warranty does not cover claims due to an insignificant defect of the device. In other respects, the customer may only demand remedy for the defect, which means subsequent improvement or the delivery of a replacement. The customer is entitled to choose at his discretion either to withdraw from the contract or to demand a reduction in the purchase price if the remedy of defect is unsuccessful, particularly if it is impossible, if we are unable to remedy it within a reasonable time frame, if we refuse to perform the remedy, or if delays in the remedy are culpably caused by us. The warranty period is 24 months from the date of delivery. We shall not accept responsibility for material defects related to the controller which are the result of improper or negligent handling or due to improper or unauthorized modifications, changes or repair work performed by the customer or a third party. This warranty is governed by German law.

F **Consignes de sécurité complémentaires**

Emploi conforme à l'usage prévu

L'imprimante 3D fischertechnik n'est pas un jouet ; elle est destinée aux jeunes à partir de 14 ans et doit exclusivement servir à imprimer des objets tridimensionnels appropriés avec du filament premium fischertechnik.

Conditions d'utilisation

Une pièce fraîche et bien aérée est la mieux appropriée à l'utilisation de votre imprimante 3D fischertechnik ! N'utilisez l'imprimante qu'en l'état complètement monté !

Extrudeuse / buse d'impression

Assurez-vous de pouvoir chauffer l'extrudeuse et la buse d'impression jusqu'à 250 °C (480 °F). Une manipulation non conforme ou le contact avec ces pièces risque de causer des brûlures graves ! Nous vous recommandons, de ce fait, de toujours laisser le capot de protection en place devant l'extrudeuse et la buse d'impression.

Pièces mobiles

Respectez toujours une distance suffisante par rapport à l'imprimante 3D en service en veillant à ce que vos vêtements ou cheveux ne puissent pas être entraînés par l'appareil. Il est par ailleurs strictement interdit d'introduire quoi que ce soit dans l'espace d'impression (lit d'impression, apport de matière, axe X, Y, Z etc.). Attention au risque de blessures ! N'utilisez jamais l'imprimante 3D sans les capots de protection s'y rapportant.

Filament

Le filament PLA fischertechnik est un produit spécialement conçu et testé pour votre imprimante 3D. Ce filament est disponible séparément et de différentes couleurs dans la boutique en ligne fischertechnik. L'utilisation d'autres filaments risque de donner des résultats de mauvaise qualité, voir d'endommager l'imprimante. Le recours à la garantie et la responsabilité de fischertechnik est exclu dans de tels cas !

Sécurité électrique

Ne pas utiliser l'imprimante 3D en plein air ! Protéger l'appareil contre l'humidité ! Ne jamais commuter le transformateur côté sortie avec d'autres transformateurs en parallèle ! Ne jamais continuer à utiliser le transformateur en cas d'endommagement du cordon ou de la fiche d'alimentation ou du boîtier ! Le contrôle et le raccordement des appareils relèvent de la responsabilité des surveillants ! Il est interdit de court-circuiter les bornes de raccordement ! L'utilisation de l'imprimante 3D est exclusivement permise avec le bloc d'alimentation fourni (19 VCC/6,3 A).

Défauts électromagnétiques

Si l'imprimante 3D venait à être perturbée par des incidences électromagnétiques externes, vous pouvez continuer à l'utiliser conformément à sa destination dès la fin des perturbations. Il se pourrait qu'il soit éventuellement requis de couper brièvement l'alimentation en courant et de redémarrer le Controller et la connexion USB.

Garantie

fischertechnik GmbH garantit l'absence de défauts de l'appareil selon le niveau actuel des connaissances techniques. Toutes les modifications de la construction ou du modèle sans incidence ni sur l'aptitude au fonctionnement ni sur la valeur de l'appareil, sont réservées et ne donnent aucun droit à réclamation. Les vices apparents doivent être signalés par écrit dans les 14 jours suivant la livraison, à défaut de quoi tout recours en garantie pour vice apparent est exclu.

Les défauts négligeables de l'appareil ne donnent pas lieu à un recours en garantie. En outre, le client peut uniquement exiger une exécution ultérieure, c.-à-d. une amélioration ou un échange standard. Le client est en droit, au choix, de se rétracter du contrat ou d'exiger une diminution du prix d'achat en cas d'échec de l'exécution ultérieure, en particulier lorsque celle-ci est impossible, lorsque nous n'y parvenons pas dans un délai raisonnable, lorsque nous la refusons ou lorsqu'elle est retardée par nous de façon dommageable. La garantie est de 24 mois à compter de la livraison. Toute défaillance du Controller survenant par manipulation incorrecte, usure habituelle, traitement erroné

ou négligé nous incombe aussi peu que pour les conséquences des modifications ou travaux de réparation inappropriés et entrepris sans notre accord par le client ou par tout tiers. La garantie est régie par le droit allemand.

Responsabilités

fischertechnik GmbH décline toute responsabilité pour les dommages résultant d'une utilisation non conforme à l'usage prévu de l'imprimante 3D.

NL Overige veiligheidsaanwijzingen

Reglementair gebruik

De fischertechnik 3D-printer is geen speelgoed. Hij is uitsluitend bedoeld voor jongeren vanaf 14 jaar om met fischertechnik Premium Filament 3-D-objekten te printen.

Gebruiksomstandigheden

Om uw fischertechnik 3D-printer te gebruiken is een koele en goed geventileerde ruimte het meest geschikt! Gebruik de printer uitsluitend in volledig gemonteerde toestand!

Extruder / printspuitmond

Houd er rekening mee dat de extruder en de printspuitmond wel 250° (480°F) heet kunnen worden. Door ondeskundig gebruik of aanraken van deze delen kunt u ernstige brandwonden oplopen! Laat daarom de veiligheidsafdekking altijd op de extruder en de printspuitmond zitten.

Bewegende delen

Zorg dat tijdens de werking van de 3D-printer altijd voldoende afstand worden gehouden zodat kleding of haren niet kunnen vastraken in het apparaat. Bovendien mag u tijdens de werking niet in de printruimte (printbed, materiaalvoeder, X-/Y-/Z-as etc.) grijpen.

Voorzichtig letselgevaar! Gebruik de 3D-printer nooit zonder de daarvoor bedoelde veiligheidsafdekkingen.

Filament

Het fischertechnik PLA-filament is speciaal voor uw 3D-printer ontwikkeld en getest. Dit filament is los in verschillende kleuren verkrijgbaar in de fischertechnik online shop.

Gebruik van andere filamenten kan leiden tot een slechte printkwaliteit of zelfs beschadiging van de printer. Dit heeft tot gevolg dat de garantie komt te vervallen!

Elektrische veiligheid

Gebruik de 3D-printer niet buiten! Bescherm hem tegen vocht! Schakel de transformator aan uitgangszijde nooit parallel met andere transformatoren! Bij beschadiging van de voedingskabel, de stekker of de behuizing mag de transformator niet meer worden gebruikt! Voor controle en aansluiting van de apparaten zijn de ouders of voogden verantwoordelijk! Aansluitklemmen mogen niet worden kortgesloten! De 3D-printer mag uitsluitend met de meegeleverde netadapter (19VDC/6,3A) worden gebruikt.

Elektromagnetische storingen

Als de 3D-printer storing ondervindt door elektromagnetische invloeden, kan hij als de storing voorbij is, weer gewoon worden gebruikt. Eventueel moet u de voeding van de Controller en de USB-verbinding kort onderbreken en de Controller opnieuw starten.

Garantie

fischertechnik GmbH verleent garantie op de goede werking van het apparaat conform de desbetreffende stand van de techniek. Wijzigingen in de constructie of uitvoering, die niet van invloed zijn op de werking noch op de waarde van het apparaat, blijven voorbehouden en kunnen niet het onderwerp zijn van reclamaties. Zichtbare gebreken moeten binnen 14 dagen na levering schriftelijk worden gemeld anders zijn garantieclaims in verband met zichtbare gebreken uitgesloten.

Er wordt geen garantie gegeven op onbeduidende gebreken van het apparaat. Voor het overige is de klant alleen gerechtigd correcte nakoming achteraf te eisen, d.w.z. reparatie achteraf of levering achteraf van een vervangend onderdeel. De klant is gerechtigd, om naar eigen goeddunken de koopovereenkomst te ontbinden of verlaging van de verkoopprijs te verlangen, als wij bij correcte nakoming achteraf in gebreke blijven, in het bijzonder als deze niet binnen een redelijke termijn wordt uitgevoerd, uitvoering daarvan door ons wordt geweigerd of door ons verwijtbaar wordt vertraagd. De garantietermijn bedraagt 24 maanden vanaf de levering. Voor gebreken aan de Controller, die zijn ontstaan door een ondeskundig gebruik, normale slijtage, een verkeerde of slechte behandeling, zijn wij niet aansprakelijk. Evenmin zijn wij aansprakelijk voor de gevolgen van ondeskundige of zonder onze toestemming uitgevoerde aanpassingen of reparaties door de klant of door derden. De garantieverlening wordt geregeld door Duits recht.

Aansprakelijkheid

fischertechnik GmbH is niet aansprakelijk voor schade die is veroorzaakt doordat de 3D-printer niet volgens de voorschriften is gebruikt.

E Otras indicaciones de seguridad

Uso conforme a lo previsto

La impresora 3D fischertechnik no es un juguete y está indicada exclusivamente para jóvenes a partir de 14 años, para imprimir objetos 3D de filamento fischertechnik Premium.

Condiciones de funcionamiento

Para el funcionamiento de la impresora 3D fischertechnik lo más adecuado es un lugar fresco y bien ventilado. ¡Haga funcionar la impresora solo completamente montada!

Extrusora / boquilla de impresión

Tenga en cuenta que la extrusora y la boquilla de impresión pueden calentarse hasta 250 °C (480 °F). ¡El manejo incorrecto o el contacto con estas piezas pueden producir quemaduras graves! Por tal razón, deje siempre la cubierta de protección colocada delante de la extrusora y la boquilla de impresión.

Piezas móviles

Preste atención a mantener una distancia suficiente durante el funcionamiento de la impresora 3D, y a que la ropa y los cabellos no se enreden en el aparato. Además, durante el funcionamiento no debe introducir las manos en el compartimento de impresión (lecho de impresión, alimentación de material, ejes X, Y y Z, etc.).

Atención: ¡Peligro de lesiones! No haga funcionar nunca la impresora 3D sin las cubiertas de protección previstas.

Filamento

El filamento de PLA fischertechnik fue especialmente desarrollado y comprobado para la impresora 3D. Este filamento está disponible por separado y en distintos colores en la tienda online de fischertechnik. El uso de otros filamentos puede conllevar una impresión de mala calidad o incluso daños en la impresora. ¡Esto tendrá como consecuencia la pérdida de la garantía!

Seguridad eléctrica

¡No hacer funcionar la impresora 3D al aire libre! ¡Proteger de la humedad! ¡No conectar nunca el transformador en el lado de la salida en paralelo con otros transformadores! ¡El transformador no debe seguir usándose en caso de daños en la línea de conexión, el enchufe o la caja! ¡La comprobación y conexión de los aparatos son responsabilidad de los encargados de la supervisión! ¡Los bornes de conexión no pueden ser puestos en cortocircuito! La impresora 3D debe utilizarse únicamente con la fuente de alimentación suministrada (19 V CC/6,3 A).

Interferencias electromagnéticas

Si la impresora 3D sufriera interferencias electromagnéticas, se la podrá continuar utilizando conforme a lo previsto una vez finalizada la interferencia. Eventualmente será necesario interrumpir brevemente la alimentación de corriente del Controller y la conexión USB, y reiniciar el Controller.

Garantía

fischertechnik GmbH garantiza la ausencia de fallos en el aparato de acuerdo al correspondiente estado de la técnica. Modificaciones en la construcción o la ejecución que no afecten ni la capacidad funcional ni el valor del dispositivo nos quedan reservadas y no otorgan derecho a una reclamación. Las deficiencias evidentes deben ser reclamadas dentro de los 14 días posteriores a la entrega, en caso contrario los derechos de garantía debido a deficiencias evidentes están descartados.

No existe ningún derecho de garantía debido a alguna deficiencia irrelevante en el aparato. Por lo demás, el cliente puede solicitar sólo una solución posterior, esto es, mejoras o suministro de sustitución. El cliente tiene el derecho de renunciar del contrato a su elección o de solicitar la reducción del precio de compra, si la solución posterior es fallida, especialmente si es imposible, o no acertamos en un periodo apropiado, nos negamos o se retrasa por nuestra parte de forma culpable. La garantía es de 24 meses a partir de la entrega. Por defectos materiales del Controller derivados de un tratamiento incorrecto, desgaste usual, trato erróneo o negligente, no nos responsabilizamos, del mismo modo que por las consecuencias de modificaciones o trabajos de conservación indebidos del cliente o terceros realizados sin nuestro consentimiento. La garantía está determinada de acuerdo a la legislación alemana.

Responsabilidad

Queda excluida toda responsabilidad de fischertechnik GmbH por daños que resulten de un uso no conforme a lo previsto de la impresora 3D.

P Otros avisos de segurança

Uso conforme o especificado

A impressora 3D fischertechnik não é um brinquedo. É indicada para jovens de 14 anos ou mais e exclusivamente para a impressão de objetos 3D a partir de filamento fischertechnik Premium.

Condições de operação

Para a operação de sua impressora 3D fischertechnik, o mais apropriado é um ambiente frio e bem ventilado. Utilize a impressora apenas se ela estiver completamente montada!

Extrusora/bico de impressão

Note que a extrusora, bem como o bico de impressão, podem aquecer até 250° (480°F). A manipulação incorreta ou o contato com essas peças podem causar queimaduras graves! Por este motivo, sempre mantenha a cobertura protetora diante da extrusora e do bico de impressão.

Peças móveis

Durante a operação da impressora 3D, deve ser mantida uma distância suficiente para que as roupas ou os cabelos não se prendam no dispositivo. Além disso, durante a operação não é permitido tocar na área de impressão (mesa de impressão, fornecimento de material, eixos X, Y e Z, etc.).

Atenção para o perigo de ferimentos! Nunca opere a impressora 3D sem as coberturas protetoras previstas.

Filamento

O filamento PLA fischertechnik foi desenvolvido e testado especialmente para sua impressora 3D. Este filamento pode ser obtido separadamente e em diferentes cores na loja virtual da fischertechnik. O uso de outros filamentos pode resultar em uma qualidade de impressão ruim ou até mesmo danificar a impressora. Este uso indevido resulta na perda da garantia!

Segurança elétrica

Não opere a impressora 3D ao ar livre! Proteja contra umidade! Nunca ligue a saída do transformador em paralelo com outros transformadores! Em caso de danos na conexão,

na tomada ou na carcaça, o transformador não poderá continuar em uso! A verificação e a conexão do dispositivo são de responsabilidade de quem estiver supervisionando o trabalho! Os terminais de conexão não devem ser curto-circuitados! A impressora 3D pode ser operada exclusivamente com a fonte de alimentação incluída (19 V CC/6,3 A).

Perturbações eletromagnéticas

Se a impressora 3D for perturbada devido a influências eletromagnéticas, ela poderá continuar a ser utilizada para o fim especificado depois do final da perturbação. Eventualmente, a alimentação de corrente do controlador e a conexão USB deverão ser interrompidas brevemente e o controlador reiniciado.

Prestação de garantia

A fischertechnik GmbH presta garantia para a isenção de falhas do dispositivo conforme o estado correspondente da técnica. As modificações na construção ou modelo que não influenciam nem a capacidade de funcionamento nem o valor do dispositivo permanecem ressalvadas e não dão o direito a uma reclamação. As deficiências evidentes devem ser tornadas válidas por escrito dentro de 14 dias após a entrega. Caso contrário, excluem-se as reivindicações de prestação de garantia devido a deficiências evidentes.

Devido a uma deficiência insignificante do dispositivo não existe nenhuma reivindicação de prestação de garantia. No mais, o cliente somente pode exigir execução posterior, isto é, melhoria posterior ou fornecimento de reposição. O cliente tem o direito, conforme o seu juízo, de exigir a rescisão do contrato ou a redução do preço de compra, quando a execução posterior falhar, especialmente se for impossível a nós, num período de tempo adequado, ser por nós negado ou por nós retardado culposamente. A prestação de garantia é de 24 meses a partir do fornecimento. Não nos responsabilizamos por defeitos do controlador causados por desgaste normal, manuseio inadequado, incorreto ou negligente, bem como devido a consequências de modificações incorretas e executadas sem a nossa autorização ou pelos trabalhos de reparação realizados pelo cliente ou por terceiros. A prestação de garantia é determinada conforme o direito alemão.

Responsabilidade

Exclui-se a responsabilidade da fischertechnik GmbH por danos resultantes da utilização não conforme com o fim especificado para a impressora 3D.

I Altre avvertenze di sicurezza

Impiego appropriato

La stampante 3D fischertechnik non è un giocattolo ed è adatta per ragazzi a partire da 14 anni di età esclusivamente per stampare oggetti 3D da filamento fischertechnik premium.

Condizioni operative

Per il funzionamento della vostra stampante 3D fischertechnik è indicato un locale fresco e ben areato! Utilizzare la stampante solo se è completamente assemblata!

Estrusore/ugello a pressione

Prestare attenzione perché l'estrusore e l'ugello a pressione possono scaldarsi fino a 250°C (480°F). In caso di impiego non appropriato e di contatto con questi particolari si possono subire gravi ustioni! Per questo motivo si consiglia di lasciare sempre il riparo di protezione davanti all'estrusore e all'ugello a pressione.

Particolari mobili

Durante il funzionamento della stampante 3D accertarsi che ci sia una distanza sufficiente e i capi di abbigliamento o i capelli non restino impigliati nell'apparecchio. Inoltre, durante il funzionamento non si devono inserire le mani nell'area di stampa (letto di stampa, alimentazione materiale, assi X/Y/Z ecc.).

Attenzione, pericolo di lesioni! Non utilizzare mai la stampante 3D senza le coperture di protezione previste.

Filamento

Il filamento PLA fischertechnik è stato sviluppato e testato specificatamente per la vostra stampante 3D. Questo filamento è disponibile a parte in vari colori presso il negozio online fischertechnik. L'utilizzo di altri filamenti potrebbe produrre una qualità di stampa scadente o persino danneggiare la stampante. Ciò ha come conseguenza l'annullamento della garanzia!

Sicurezza elettrica

Non utilizzare la stampante 3D all'aperto! Proteggere dall'umidità! Non collegare mai l'uscita del trasformatore in parallelo ad altri trasformatori! In presenza di cavo di allacciamento, connettore o alloggiamento danneggiati, non si deve più utilizzare il trasformatore! Gli addetti alla sorveglianza sono responsabili del controllo e dell'allacciamento degli apparecchi! I morsetti di allacciamento non devono essere cortocircuitati! La stampante 3D deve essere utilizzata esclusivamente con l'alimentatore in dotazione (19 V DC/6,3 A).

Disturbi elettromagnetici

Se la stampante 3D viene disturbata daflussi elettromagnetici esterni, al termine del disturbo si può continuare a utilizzarla senza problemi. Eventualmente si deve interrompere brevemente l'alimentazione elettrica del Controller e la connessione USB e riavviare il Controller.

Garanzia

La fischertechnik GmbH garantisce per l'assenza di difetti nell'apparecchio in conformità allo stato attuale della tecnica. Eventuali modifiche costruttive o esecutive da noi effettuate e non pregiudicanti né la capacità di funzionamento né il valore dell'apparecchio non danno diritto a reclami. Le mancanze evidenti devono essere comunicate per iscritto entro due settimane dalla consegna, altrimenti si perde il diritto a qualsiasi rivendicazione in garanzia per mancanze evidenti.

Per difetti trascurabili dell'apparecchio si esclude qualsiasi rivendicazione in garanzia. Negli altri casi il cliente può chiedere soltanto il successivo adempimento, vale a dire la riparazione o fornitura del ricambio. Il cliente è autorizzato a scegliere se recedere dal contratto o richiedere la riduzione del prezzo di acquisto, in caso di mancato adempimento successivo, in particolare se non dovessimo farcela in un periodo di tempo adeguato, nel caso venga da noi rifiutato o ritardato colposamente. Il garanzia è valida per 24 mesi

dalla consegna. Non rispondiamo per vizi del Controller che si presentano a seguito di impiego inappropriato, usura naturale, trattamento scorretto o negligente, e tanto meno per le conseguenze di modifiche effettuate in modo inappropriato o senza il nostro consenso o riparazioni eseguite dal cliente o da terzi. La garanzia si basa sul diritto tedesco.

Responsabilità

Si esclude qualsiasi responsabilità della fischertechnik GmbH per danni risultanti da un impiego non appropriato della stampante 3D.

RU Другие указания по безопасности

Применение по назначению

3D принтер fischertechnik - это не игрушка, он предназначен для молодых людей старше 14 лет и только для распечатки 3-D-объектов из филамента fischertechnik Premium.

Условия эксплуатации

Для работы вашего 3D принтера fischertechnik лучше всего подходит прохладное и хорошо проветриваемое помещение! Эксплуатируйте ваш принтер только в полностью собранном состоянии!

Экструдер / нагнетательное сопло

Учтите, что экструдер и нагнетательное сопло могут нагреваться до 250°C (480°F). При неправильном обращении или касании этих деталей возможны тяжёлые ожоги! Поэтому никогда не снимайте защитную крышку перед экструдером и нагнетательным соплом.

Подвижные части

При работе 3D принтера выдерживайте достаточное расстояние до него, чтобы в нём не запуталась одежда или волосы. Кроме того, при работе принтера нельзя дотрагиваться до камеры нагнетания (печатного стола, подачи материала, осей X/Y/Z и др.).

Осторожно, опасность получения травм! Никогда не эксплуатируйте 3D принтер без предусмотренных защитных укрытий.

Филамент

Филамент fischertechnik PLA специально разработан и протестирован для вашего 3D принтера. Этот филамент различного цвета можно отдельно приобрести в онлайн-магазине fischertechnik. Использование других филаментов может привести к плохому качеству печати или даже к повреждению принтера, а также ведёт к потере гарантии.

Электрическая безопасность

Запрещается эксплуатировать 3D принтер на открытом воздухе! Защищайте от влаги! Никогда не подключайте трансформатор на стороне выхода параллельно с другими трансформаторами! Запрещается использовать трансформатор с повреждённым соединительным проводом, штекером или корпусом! Ответственность за контроль и подключение прибора лежит на надзирающих лицах. Нельзя замыкать клеммы накоротко! 3D принтер разрешается эксплуатировать только с прилагаемым блоком питания (19V=/6,3A).

Электромагнитные помехи

Если внешние электромагнитные воздействия создают помехи для работы 3D принтера, то после окончания действия этих помех он может работать по назначению дальше. Возможно потребуются на короткое время прервать электропитание, разъединить USB-соединение и перезапустить контроллер.

Гарантия

Фирма fischertechnik GmbH предоставляет гарантию на исправность прибора соответственно состоянию техники. Мы оставляем за собой право на изменения в конструкции или исполнении, которые не ухудшают работоспособность и не влияют на стоимость прибора, и не принимаем претензий по этим вопросам. Об очевидных недостатках необходимо письменно заявить в течение 14 дней после поставки, иначе рекламации по ним исключаются.

По незначительным недостаткам прибора рекламационные претензии не принимаются. В остальном покупатель может потребовать устранения недостатков или замену изделия. Покупатель имеет право на свой выбор отказаться от изделия или потребовать снижения стоимости, если устранение недостатков не дало результатов или невозможно, его не удалось выполнить в разумные сроки, отклонено нами или если мы виновны в задержке. Срок гарантии составляет 24 месяца с момента поставки. Мы не несём ответственности за дефекты прибора, возникшие в результате неправильного обращения, обычного износа, ошибочного или небрежного обслуживания, а также за последствия изменений или ремонта, выполненных покупателем или третьими лицами неквалифицированно или без нашего разрешения. Гарантия определяется по немецкому праву.

Ответственность

Исключается ответственность fischertechnik GmbH за повреждения, возникшие в результате применения 3D принтера не по назначению.



其它安全须知

用于预期用途

慧鱼 (fischertechnik) 3D 打印机不是玩具，只给 14 岁以上的青少年用于打印由慧鱼 (fischertechnik) 顶级打印线材构成的 3D 对象。

运行条件

凉爽和通风良好的房间最适合于运行慧鱼 (fischertechnik) 3D 打印机！只可在已完全装配好的状态下运行该打印机！

挤出机/高压喷嘴

请注意，挤出机和高压喷嘴可能会被加热到 250°C (480°F)。使用不当以及接触这些部件可能会造成严重烫伤！由于该原因，请始终让保护盖位于挤出机和高压喷嘴前面。

移动部件

请注意，运行 3D 打印机时保持足够的安全距离并且不要让衣物或头发缠入打印机中。此外，运行时不允许将手伸入到打印空间（打印床、送料装置、X/Y/Z 轴等）中。

小心受伤！绝不允许在不带所提供保护盖的情况下运行该 3D 打印机。

打印线材

慧鱼 (fischertechnik) PLA 打印线材专为该 3D 打印机研发且已进行了测试。在慧鱼 (fischertechnik) 在线商店中可单独购买该打印线材，有不同的颜色。使用其它的打印线材可能导致打印质量差甚至损坏打印机。如此将失去质保和保修！

电气安全

不要在露天使用该 3D 打印机！防止受潮！绝不能将变压器的输出侧与其它变压器并联！在连接导线、插头或外壳有损坏时，不得再继续使用变压器！监督人员负责检查和连接设备！接线柱不允许被短路！只允许用随附的电源适配器 (19VDC/6.3A) 来运行该 3D 打印机。

电磁干扰

如果该 3D 打印机受到电磁干扰，则可在干扰结束后按照规定继续使用。也有可能必须短时切断控制器的电源和断开 USB 连接，然后重新启动控制器。

保修

慧鱼 (fischertechnik) 有限公司按照当时的最新技术水准对设备的无缺陷性提供担保。保留在不影响功能及使用价值的前提下更改结构或规格的权利，于这样的更改客户无权要求赔偿。明显的缺陷必须在交货后 14 天之内以有效的书面形式提出，否则会取消因明显缺陷而提出的保修要求。

对于设备无关紧要的缺陷无权要求保修。此外，用户只能要求保修包换，即修理或者供应配件。如果保修包换失败、特别是保修包换不可能，或者在一定的时间内我们没能实现保修包换，拒绝保修包换或者因我们的过失而拖延保修包换，用户则有权选择退货或要求降低购买价格。保修期为自交货后 24 个月。由于不当的操作、常见的磨损、错误及马虎的操作而引起的控制器损坏，与用户或第三方不恰当的、未经允许的更改或修理而造成的后果一样，我们概不负责。保修责任按照德国法律。

赔偿责任

因未按预期用途使用 3D 打印机而造成损失，慧鱼 (fischertechnik) 有限公司不承担任何责任。





3D Printer

1  13 x  13 x

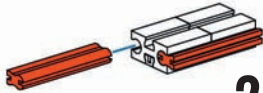



 **13 x**

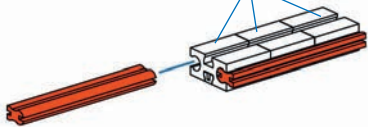

 **2 x**

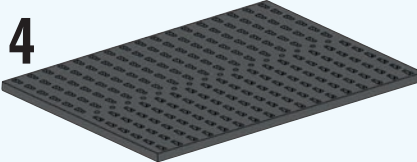
2  4 x

3  4 x



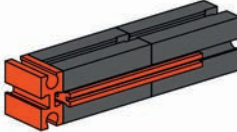

1  **2 x**

4  1 x  2 x  2 x  5 x  2 x

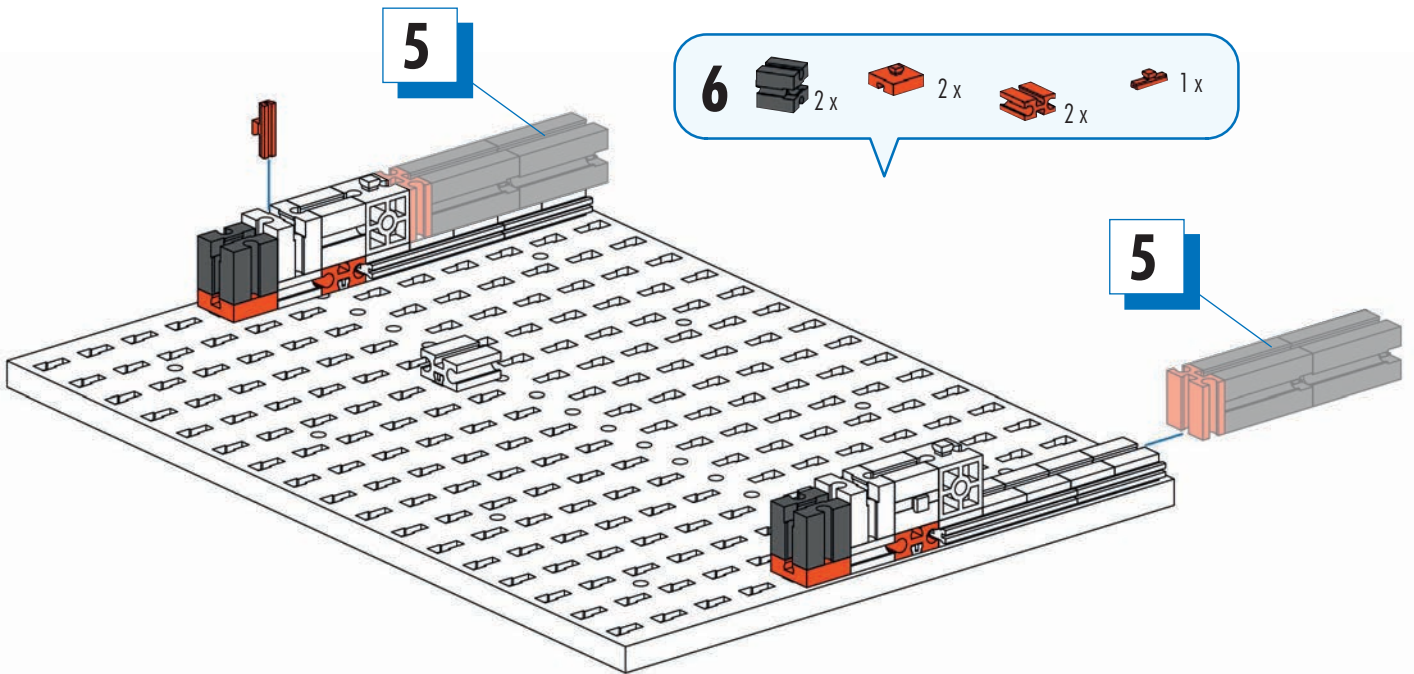
5  4 x  2 x  2 x



 2 x

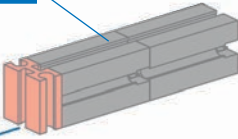
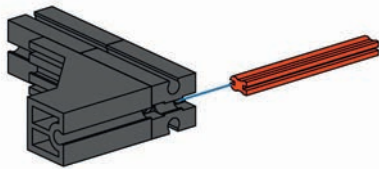

6  2 x  2 x  2 x  1 x

5

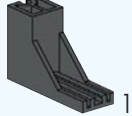
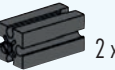
7  1 x  2 x  1 x



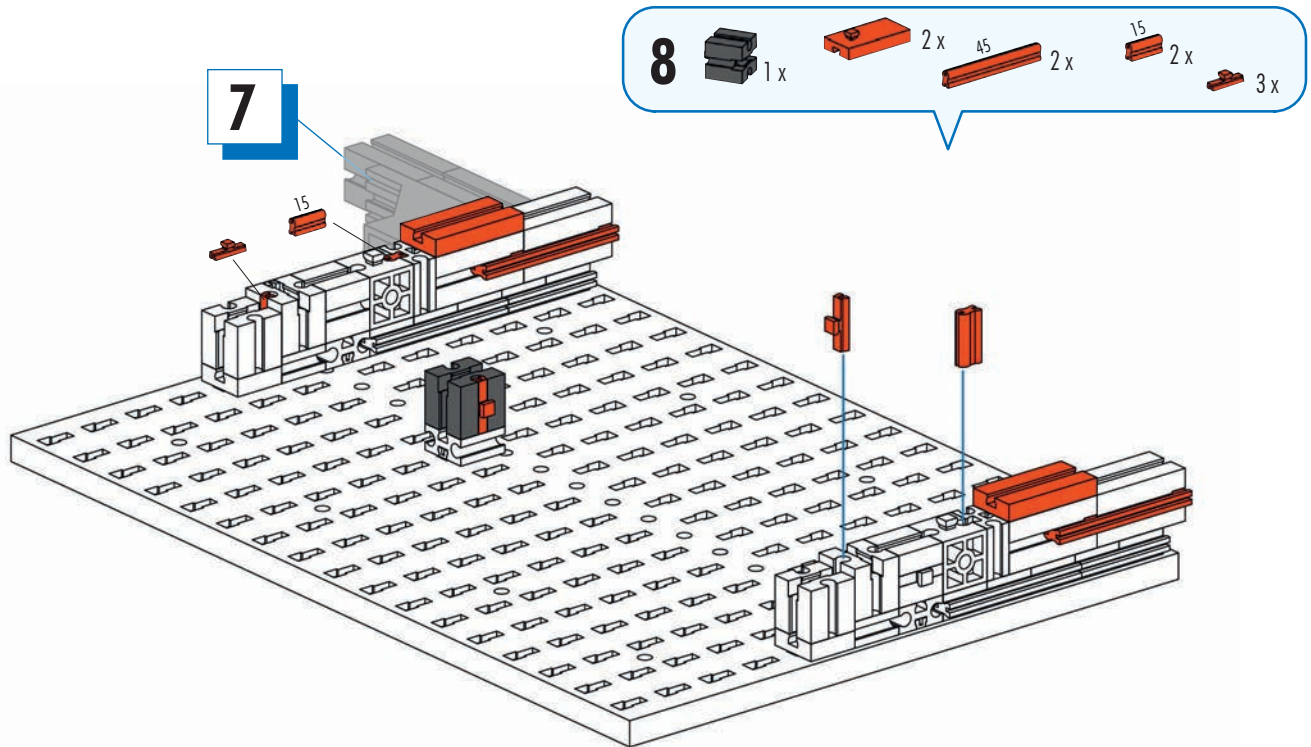

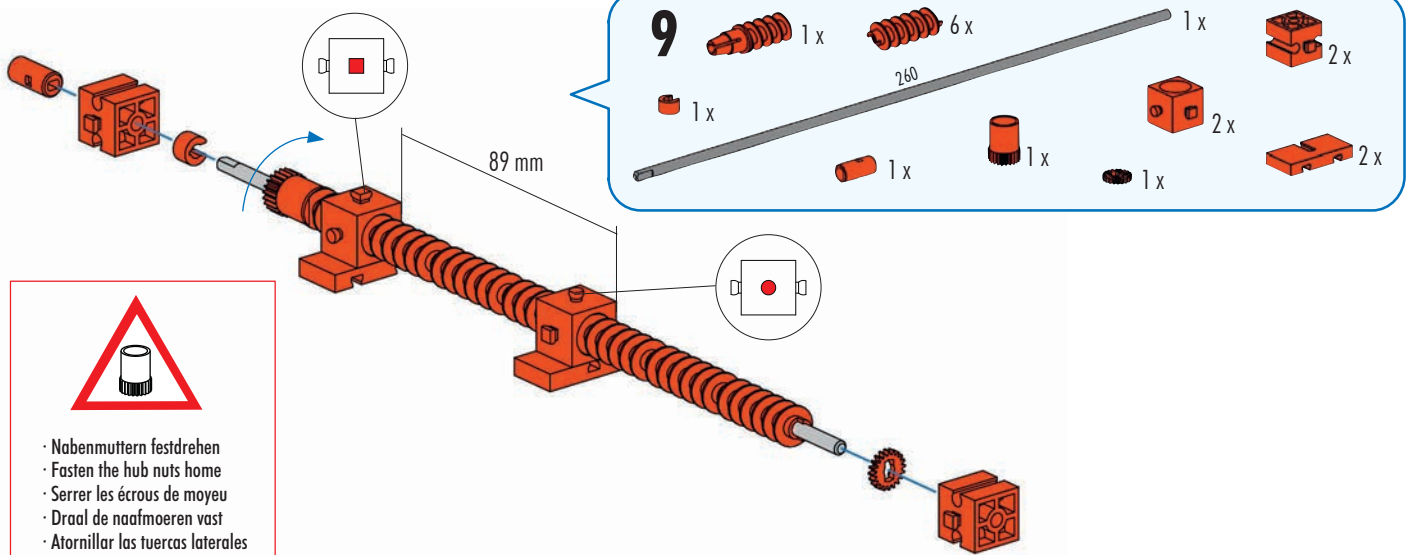

- Nabenmuttern festdrehen
- Fasten the hub nuts home
- Serrer les écrous de moyeu
- Draal de naafmoeren vast
- Atornillar las tuercas laterales
- Apertar bem as porcas de cubo
- Stringere i dadi dei mozzi
- Затянуть гайки ступиц
- 拧紧

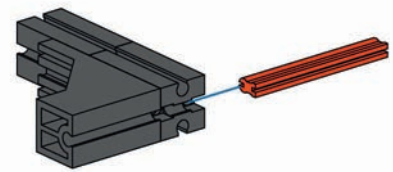
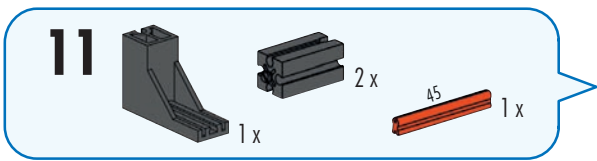
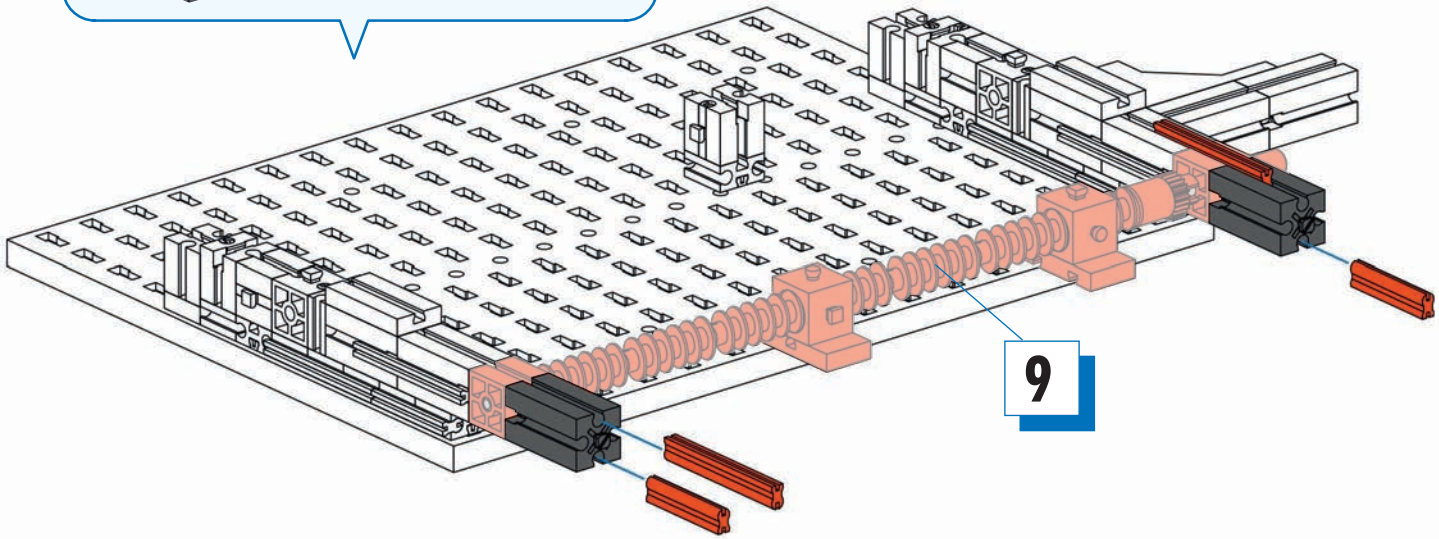
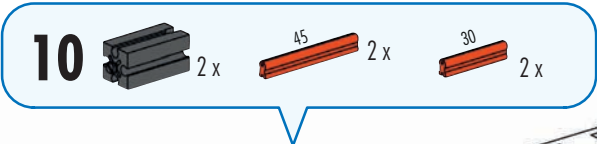

260 mm

12

- 2x [Black Technic Beam 1x3]
- 4x [Red Technic Beam 1x3]
- 1x [Black Technic Pin with Friction Ridge]
- 1x [Red Technic Pin with Friction Ridge]
- 4x [Red Technic Pin with Friction Ridge, Length 45]
- 1x [Red Technic Pin with Friction Ridge, Length 30]

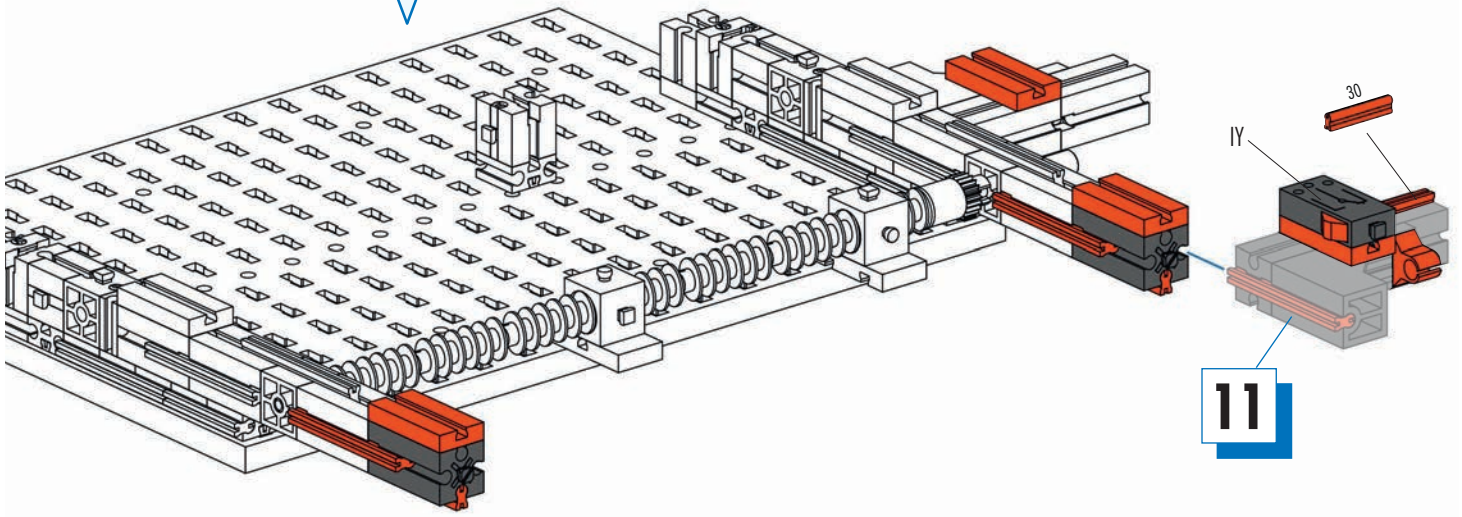

11

13

- 9x [Red Technic Beam 1x3]
- 9x [Red Technic Pin with Friction Ridge]

9x [Red Technic Beam 1x3]

14

- 4x [Red Technic Pin with Friction Ridge, Length 45]

2x [Red Technic Beam 1x3]

15

- 1x [Dark Grey Technic Plate 16x16]
- 4x [Black Technic Pin with Friction Ridge]
- 5x [Black Technic Pin with Friction Ridge]
- 4x [Black Technic Pin with Friction Ridge]
- 2x [Red Technic Pin with Friction Ridge]
- 1x [Red Technic Pin with Friction Ridge]
- 2x [Red Technic Pin with Friction Ridge]
- 6x [Red Technic Pin with Friction Ridge]
- 1x [Red Technic Beam 1x6]

14

13

14

13

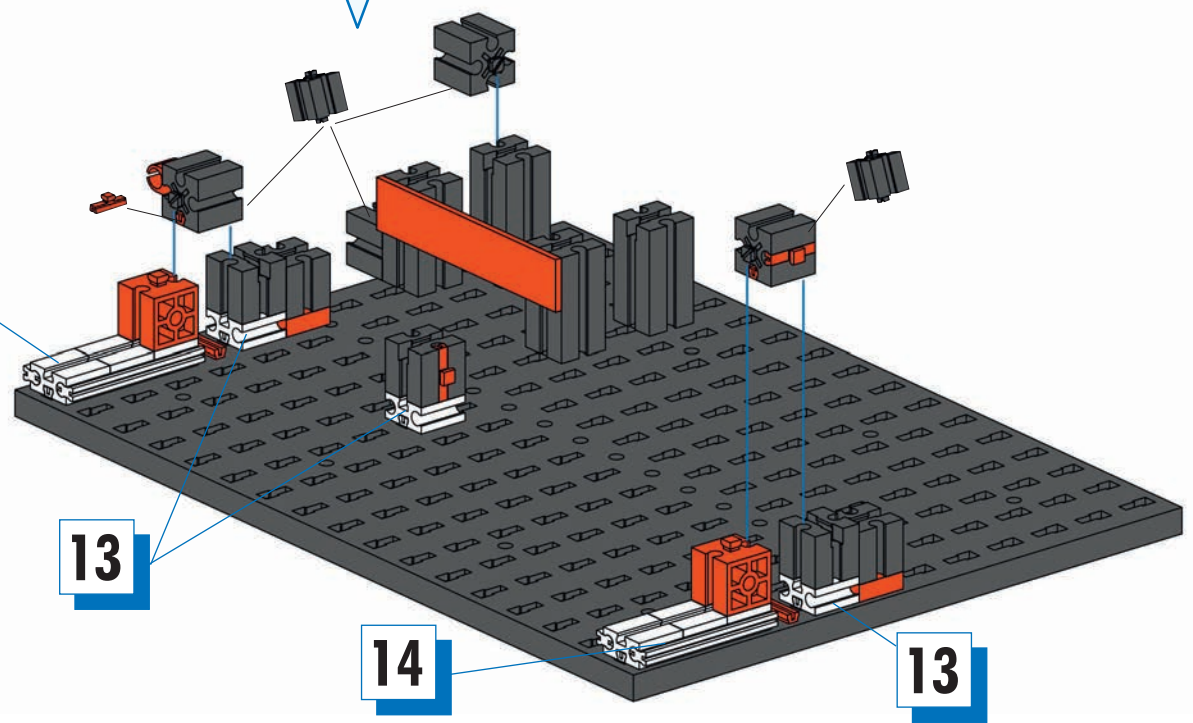

16

- 3 x [Grey Technic Pin]
- 2 x [Red Technic Pin]
- 2 x [Red Technic Pin]
- 3 x [Red Technic Pin]
- 2 x [Red Technic Pin]
- 3 x [Red Technic Pin]

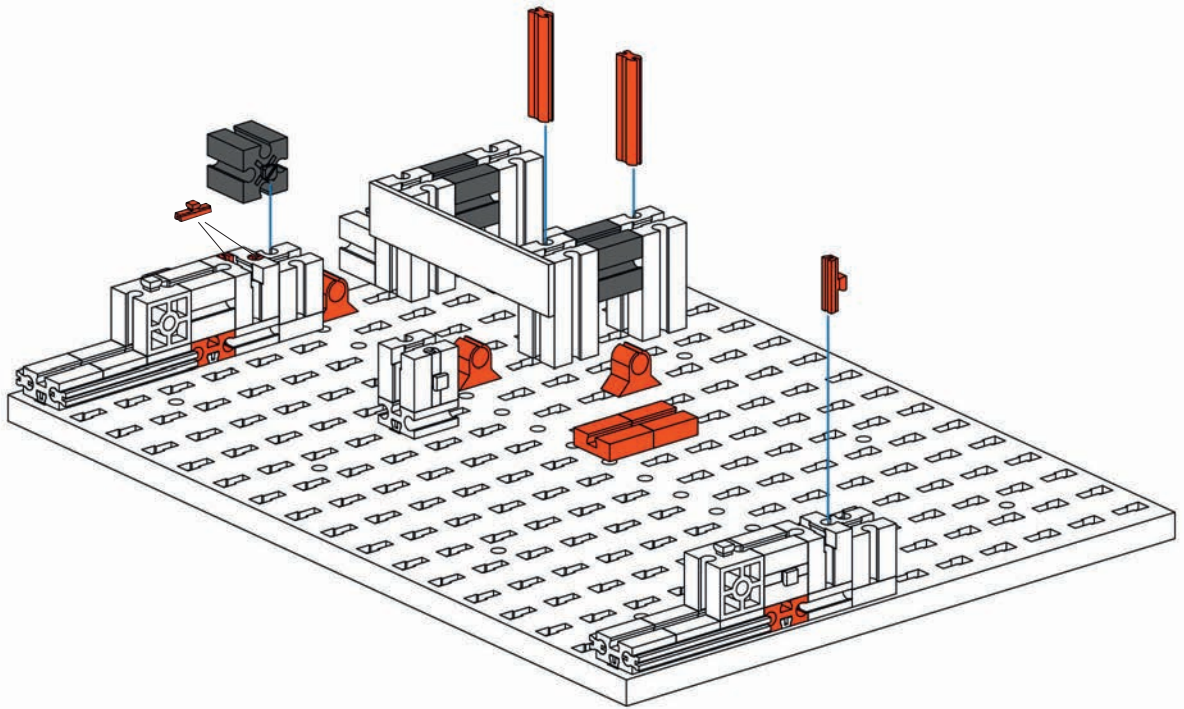

17

- 1 x [Grey Motor]
- 1 x [Grey Technic Pin]
- 1 x [Grey Technic Pin]
- 4 x [Grey Technic Pin]
- 1 x [Grey Technic Pin]
- 1 x [Red Technic Pin]
- 2 x [Red Technic Pin]
- 1 x [Red Technic Pin]
- 2 x [Red Technic Pin]
- 2 x [Red Technic Pin]
- 2 x [Red Technic Pin]

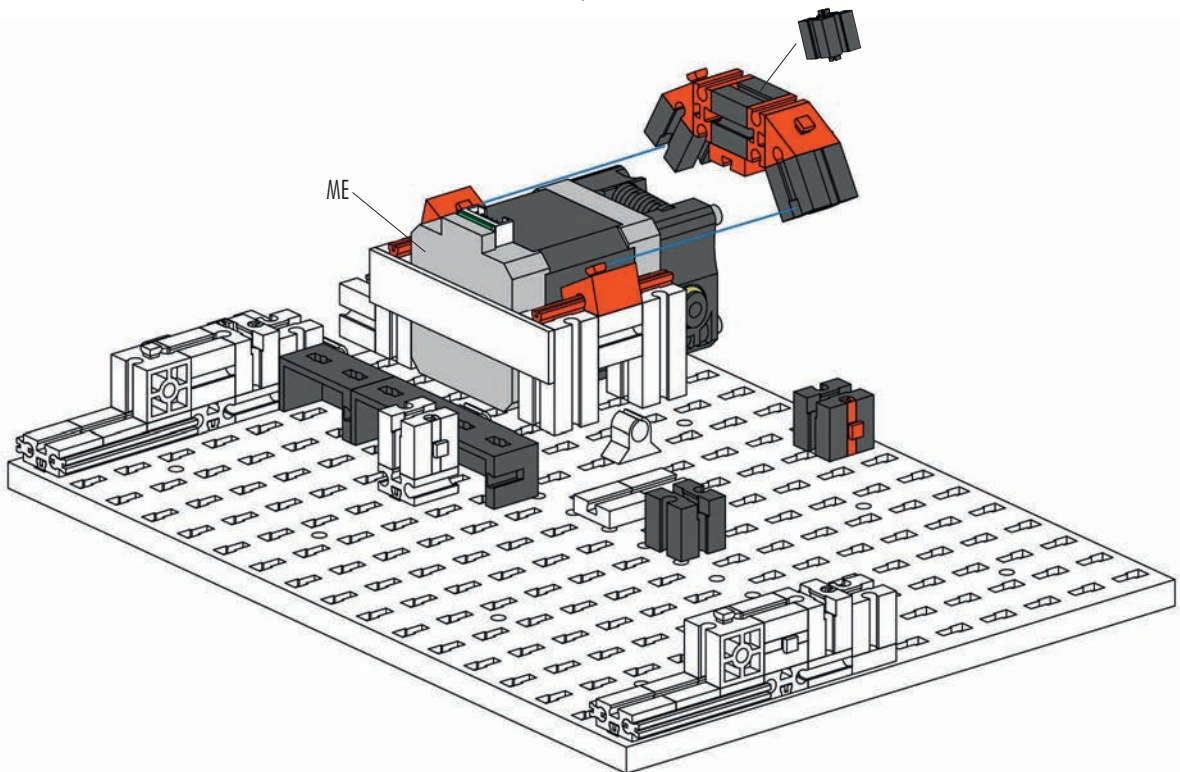

18

2x

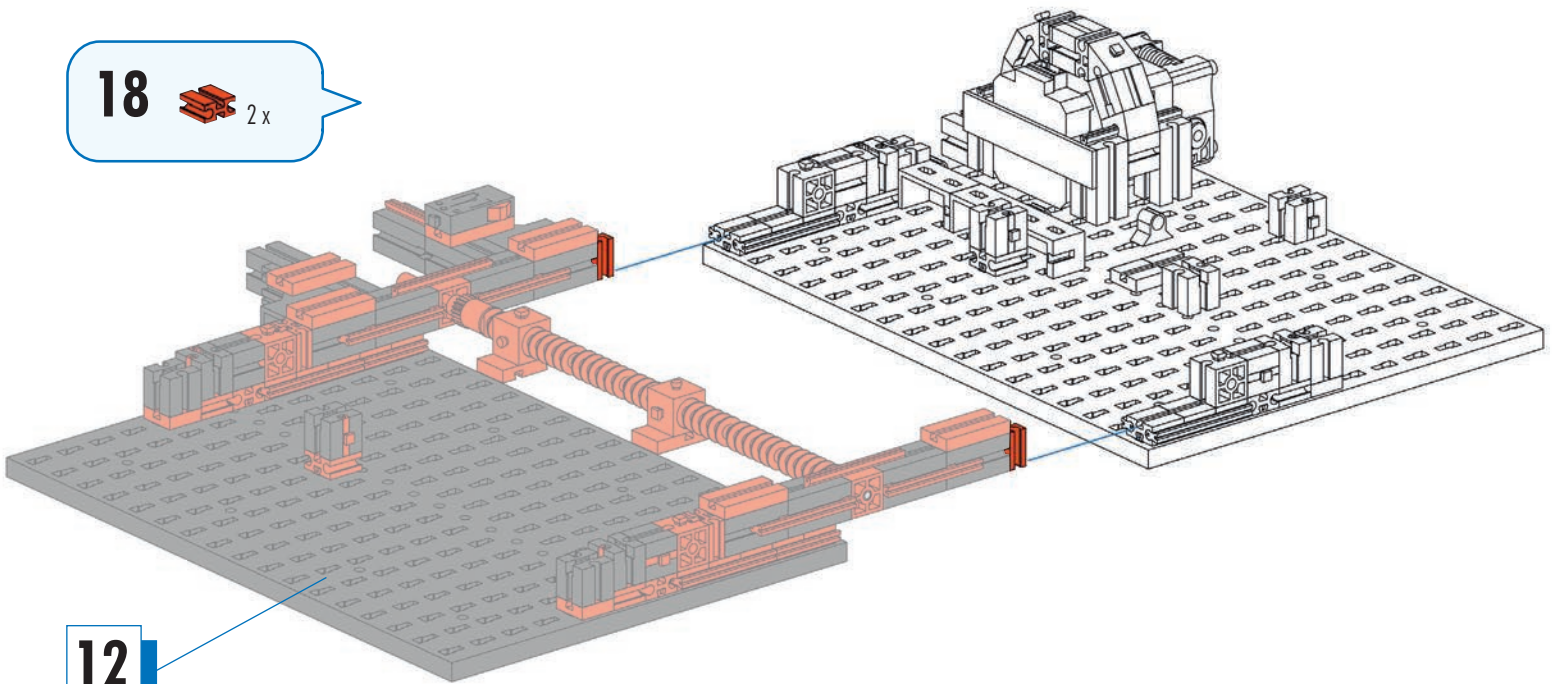

12

19

1x
4x
4x
1x

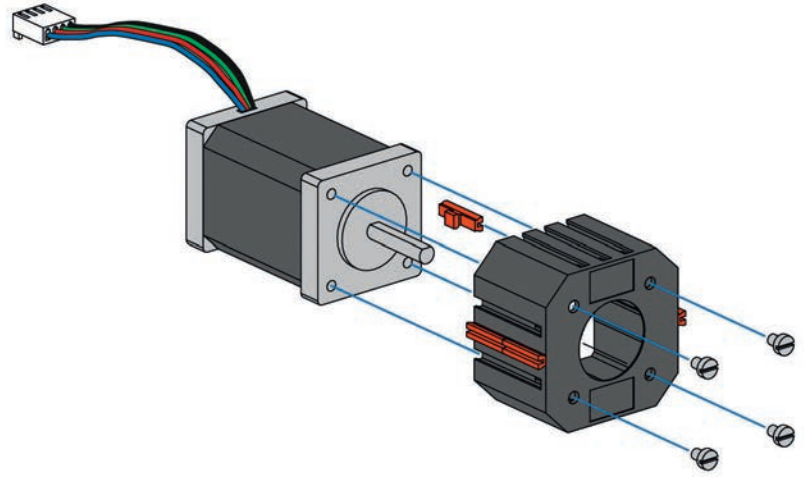

20

1x

1x

1x

2x

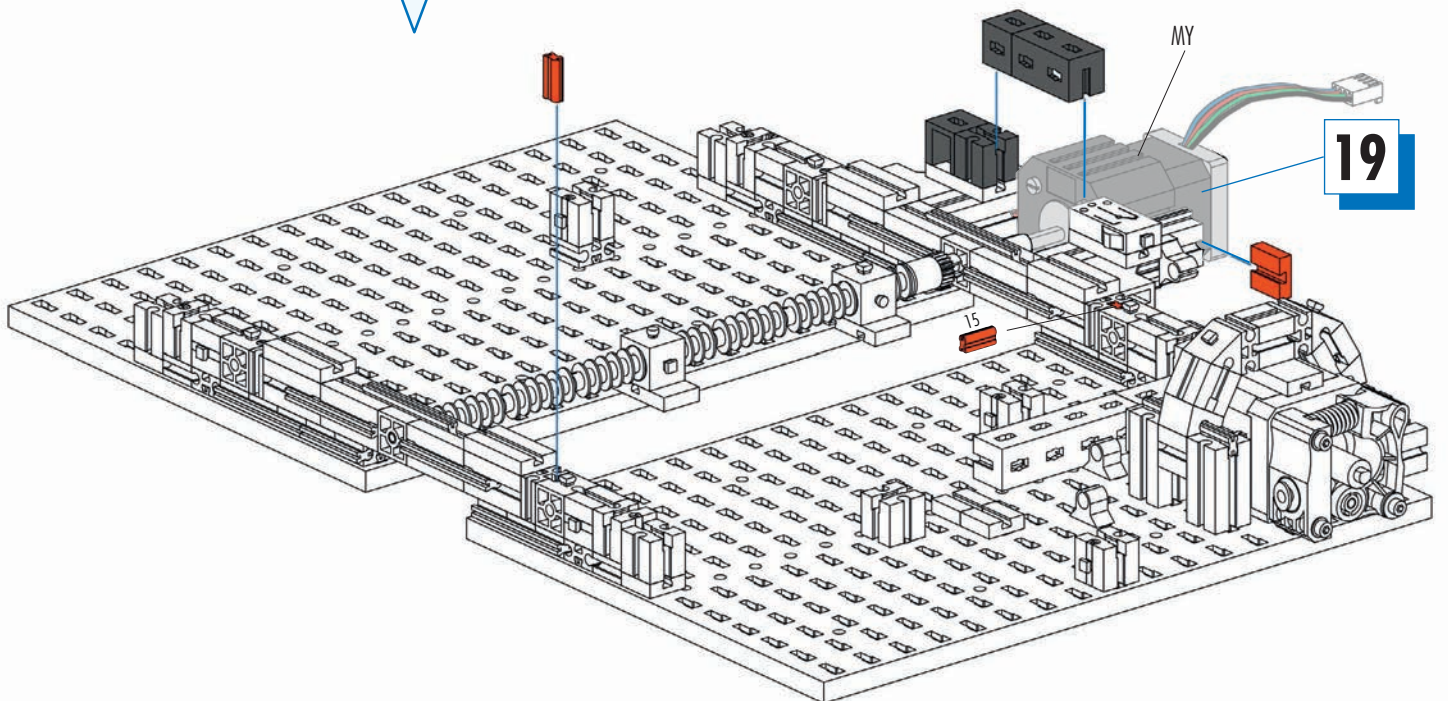

15
2x



19



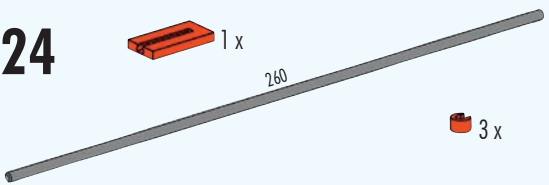

260 mm

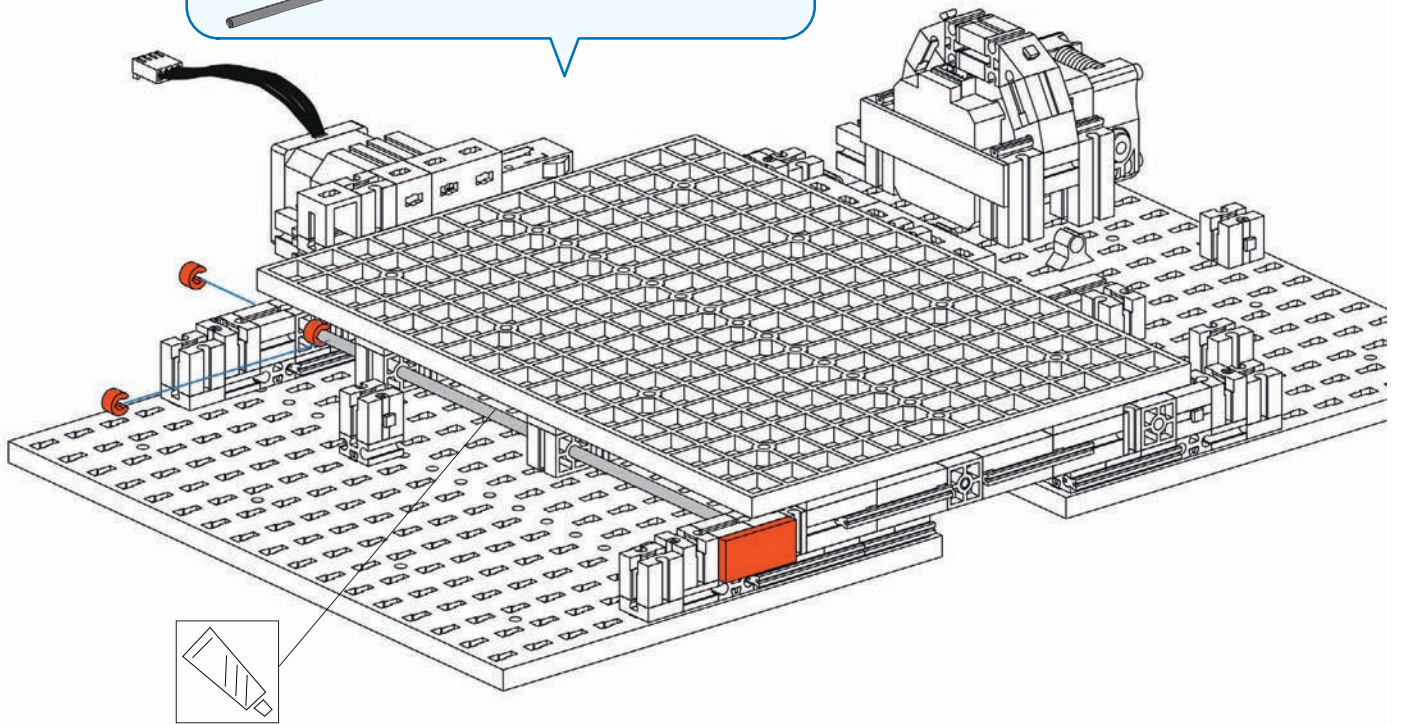
24

- 1 x 
- 1 x 
- 3 x 

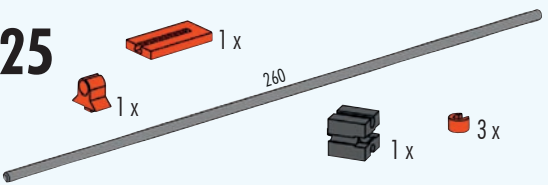

25

- 1 x 
- 1 x 
- 1 x 
- 1 x 
- 3 x 

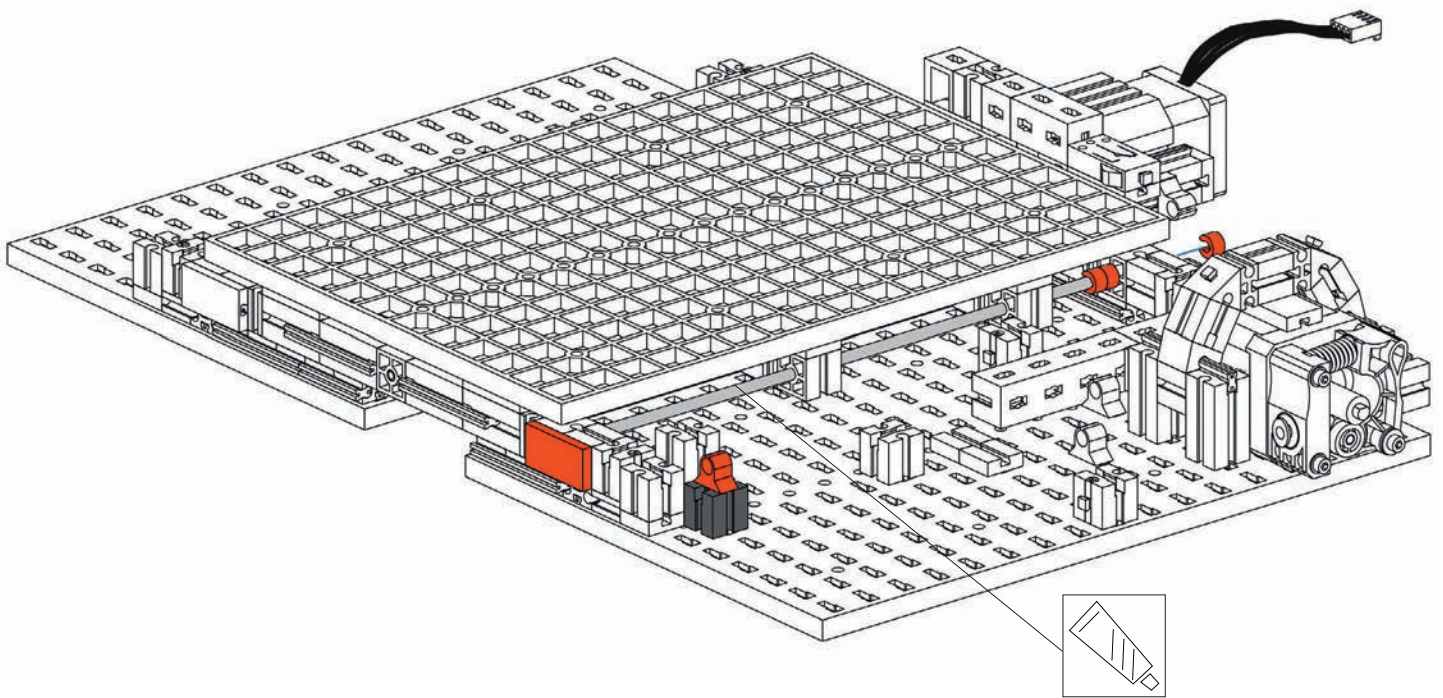

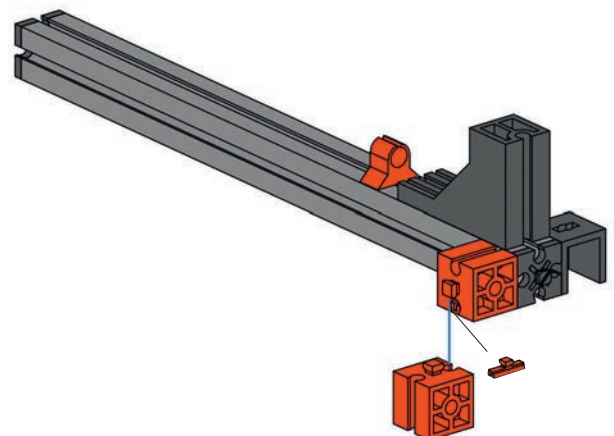
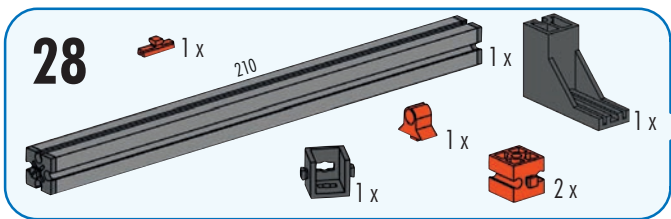
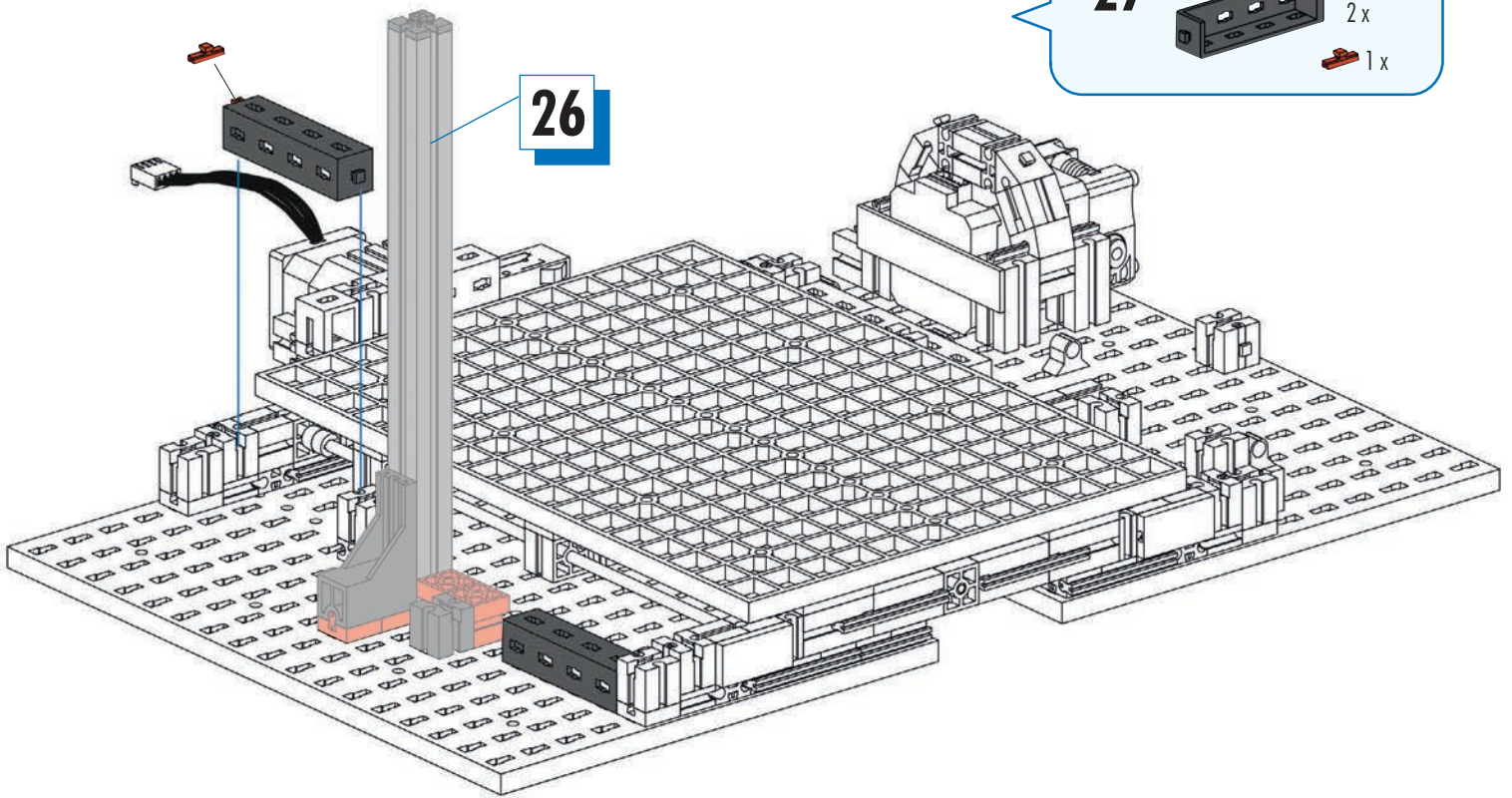
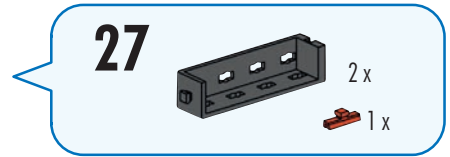
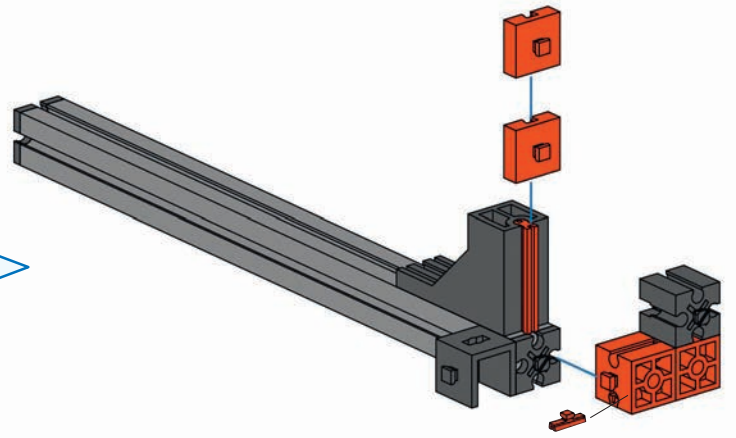
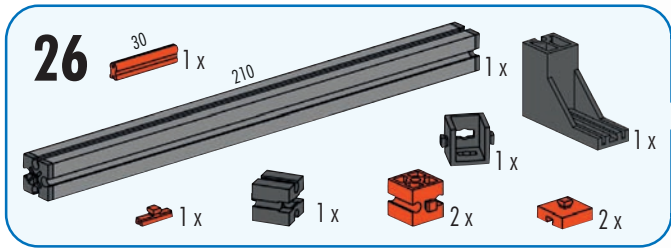

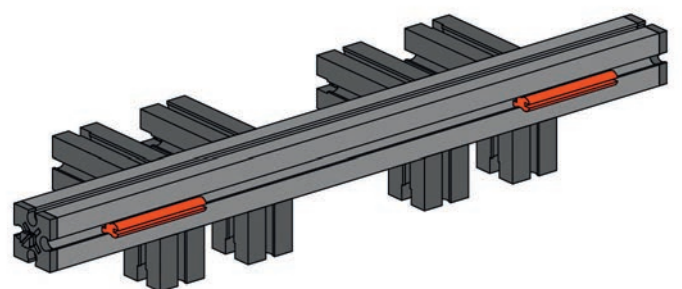
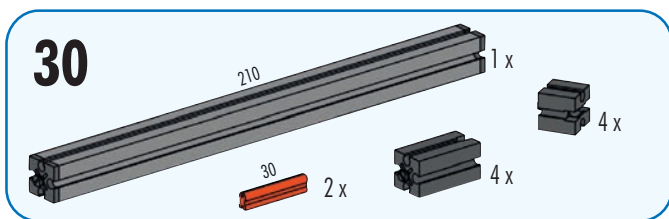
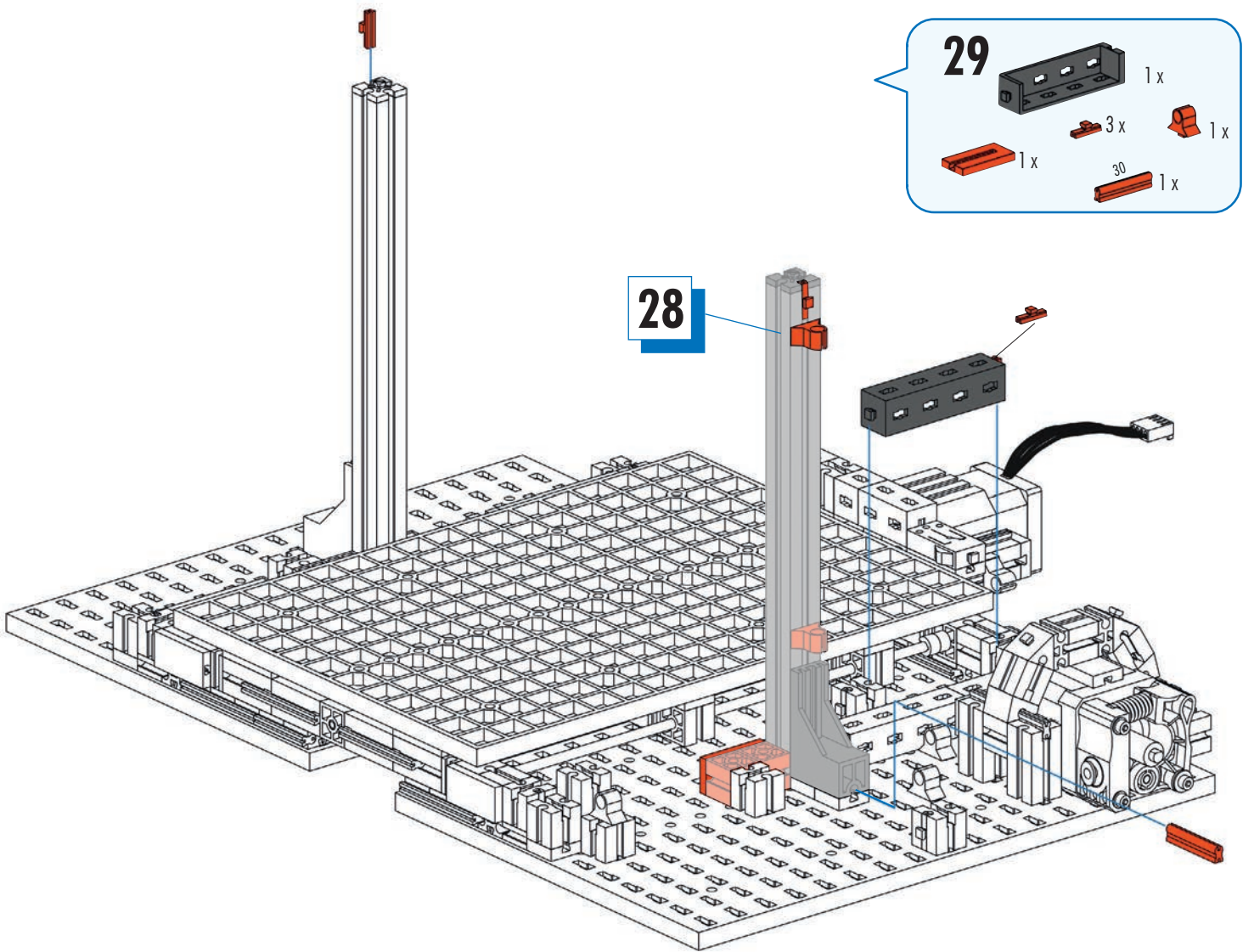

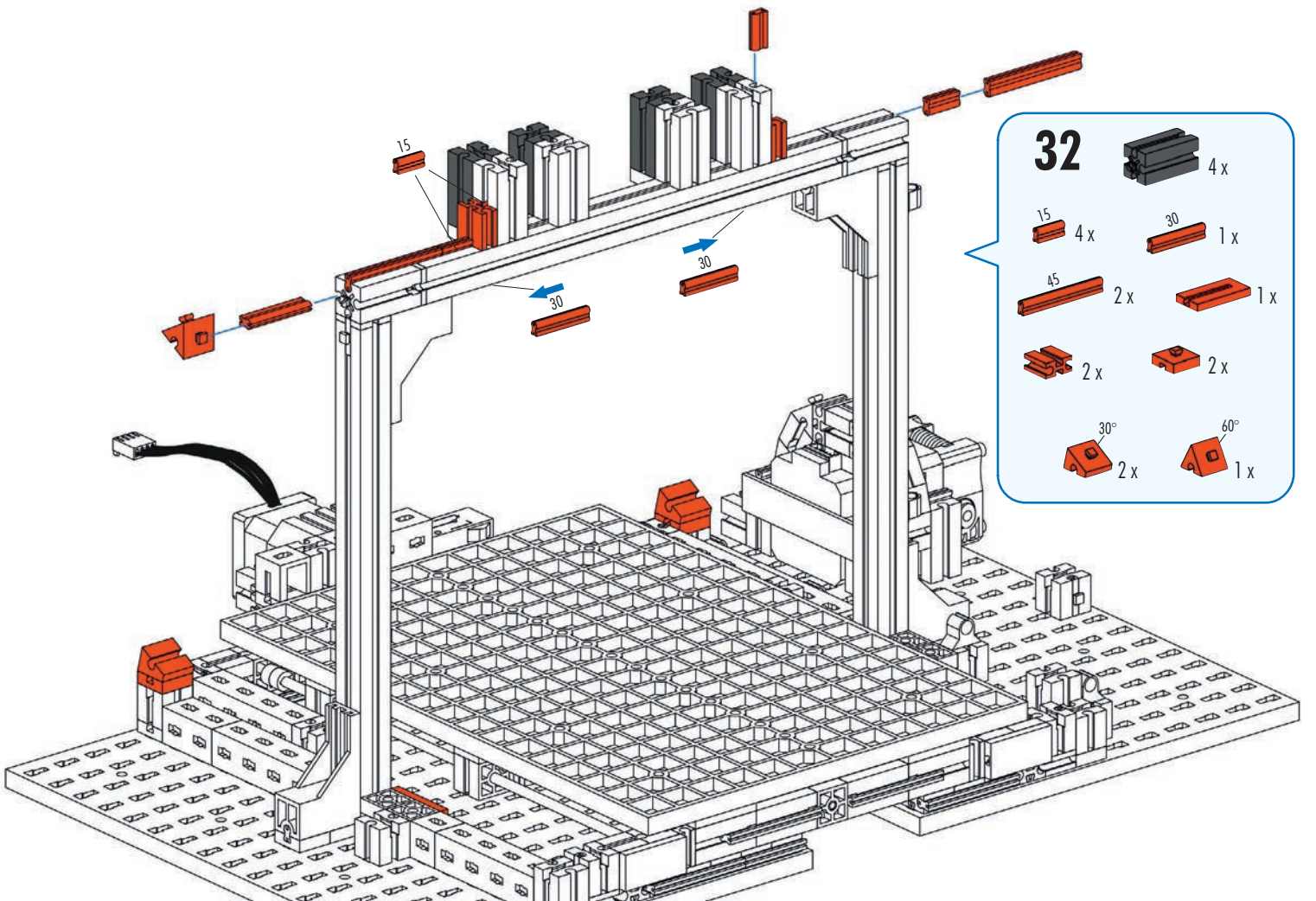
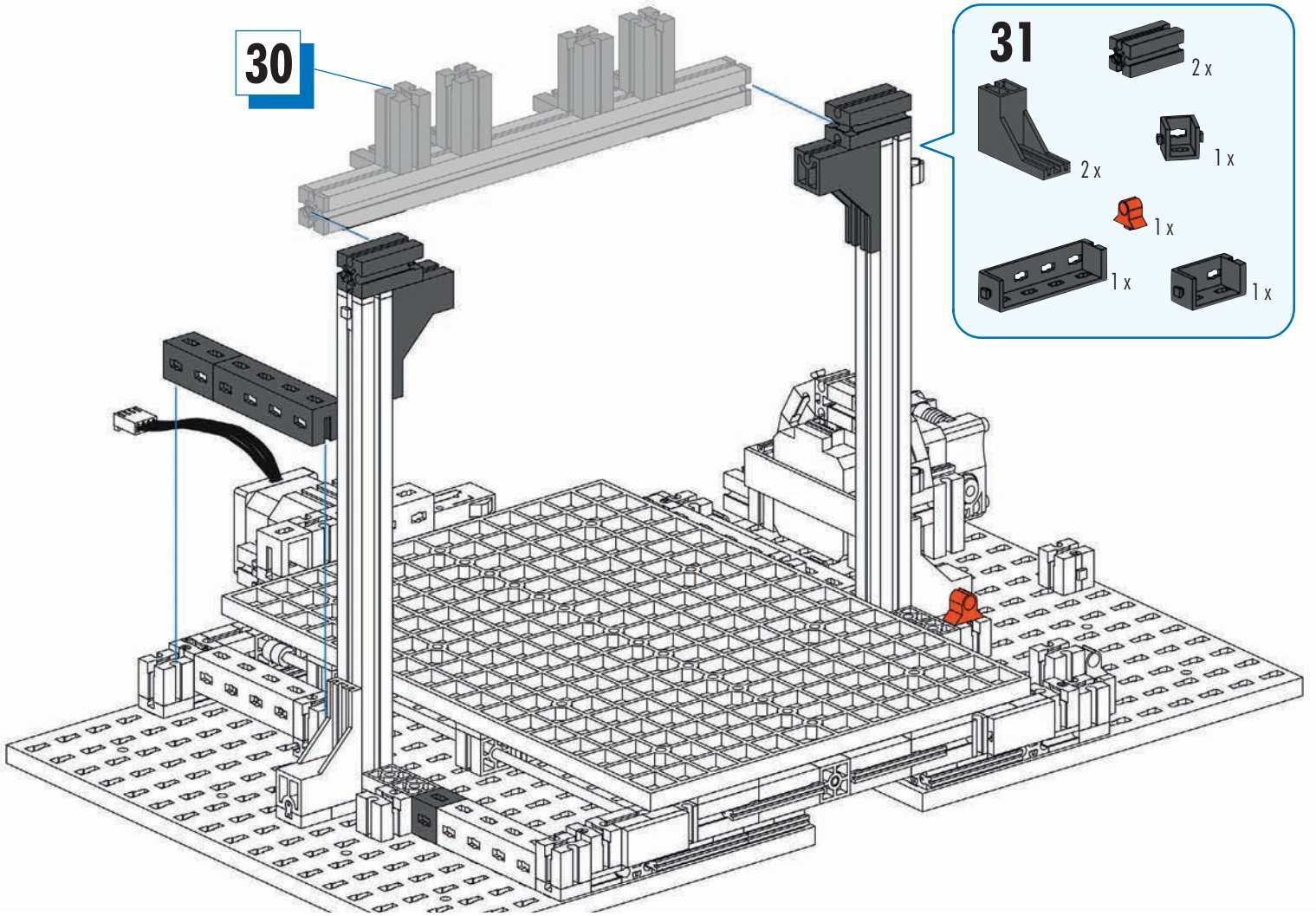

33



2 x



8 x



2 x



1 x



1 x



8 x



1 x



1 x



1 x

260 mm

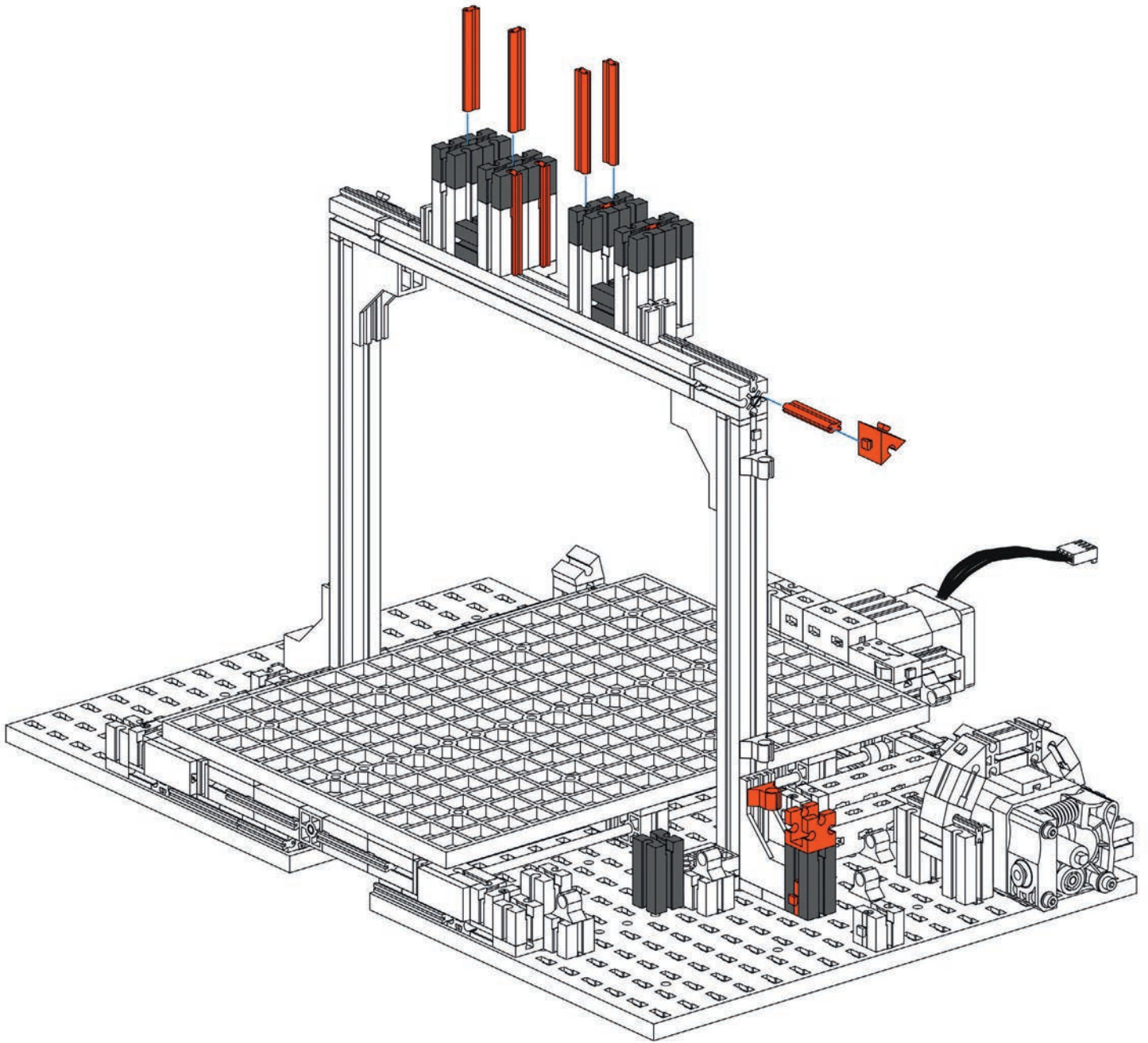



- Nabenmuttern festdrehen
- Fasten the hub nuts home
- Serrer les écrous de moyeu
- Draal de naafmoeren vast
- Atornillar las tuercas laterales
- Apertar bem as porcas de cubo
- Stringere i dadi dei mozzi
- Затянуть гайки ступиц
- 拧紧

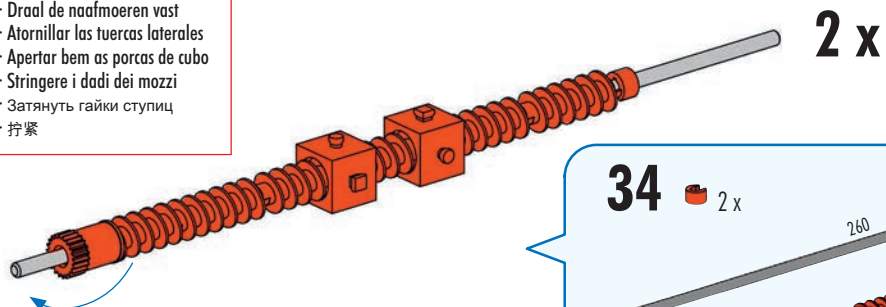

34 2 x

260 2 x

2 x

10 x

2 x

4 x

35 2 x

210 2 x

40 2 x

2 x

2 x

4 x

4 x

2 x

40 mm

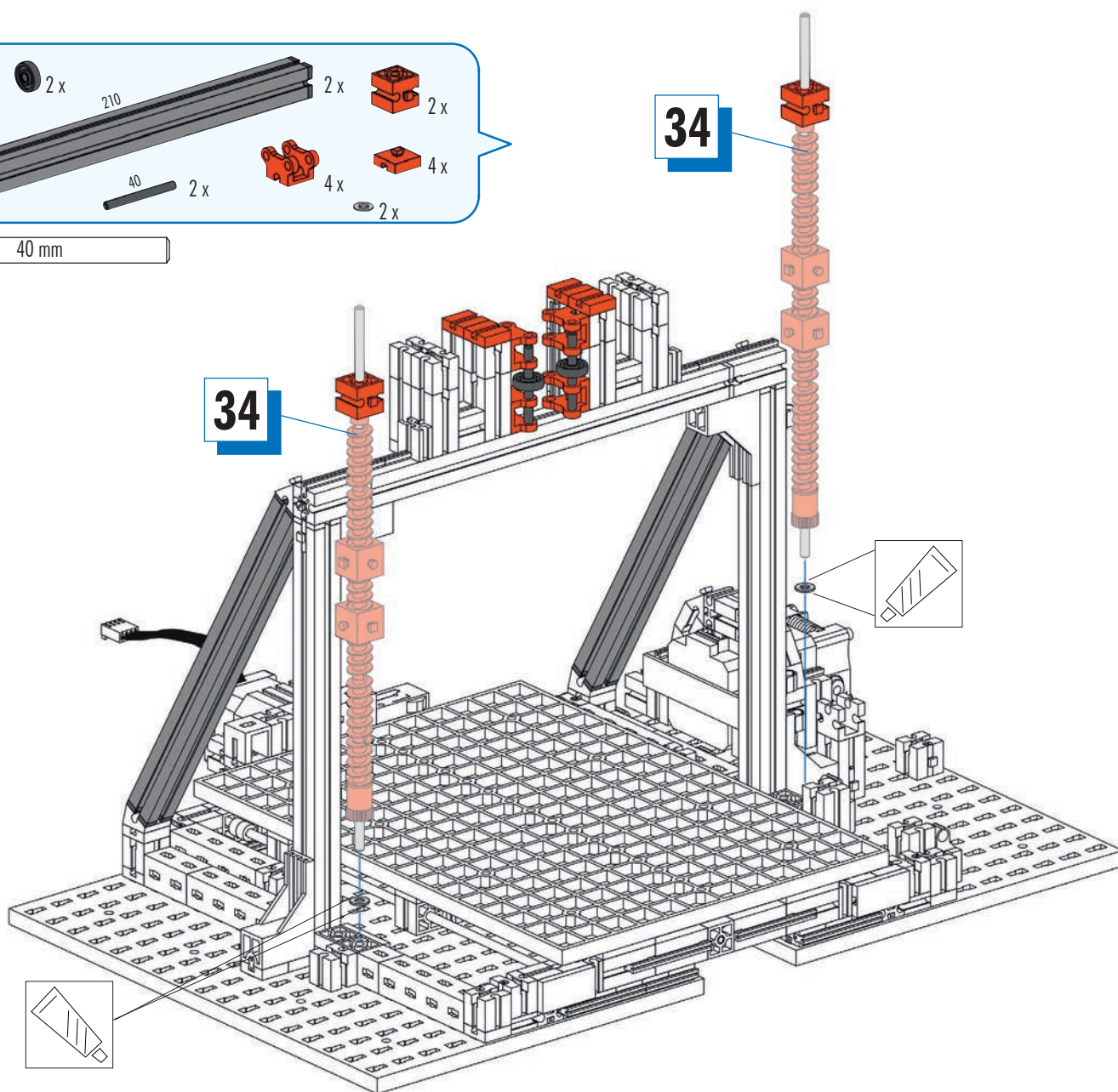

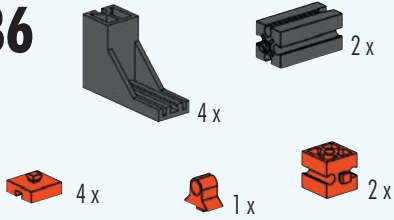
36

Achse muss leichtgängig gedreht werden können.

The axle must be easy to rotate.

La rotation de l'axe doit être souple.

As moet soepel kunnen draaien.

El eje debe poder girarse con suavidad.

O eixo deve girar com facilidade.

L'asse deve potersi ruotare facilmente.

Ось должна легко вращаться.

轴必须能够灵活转动。

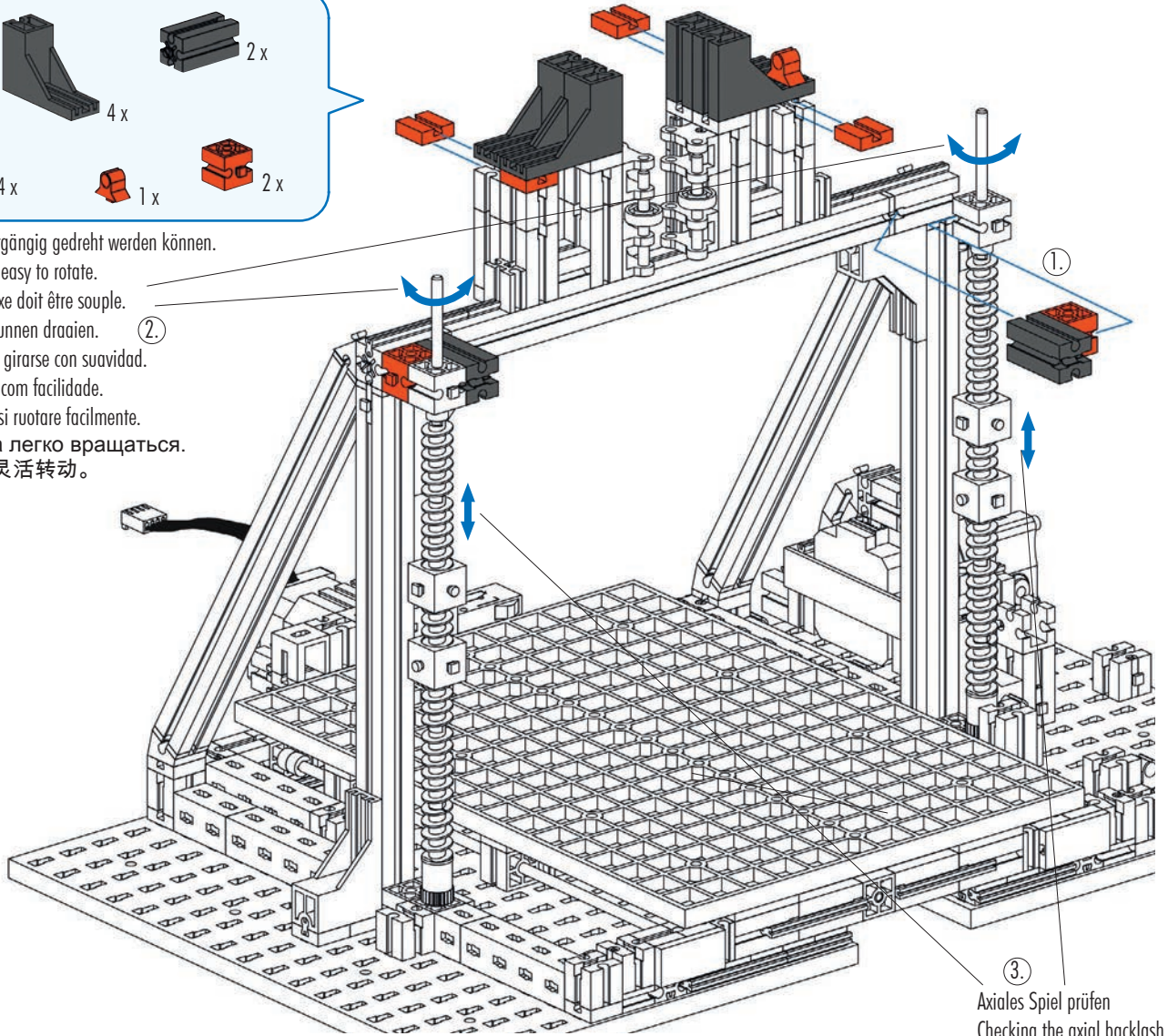

③ Axiales Spiel prüfen
Checking the axial backlash
Contrôler le jeu axial
Axiale speling controleren
Comprobar el juego axial
Verificar folga no eixo
Controllo del gioco assiale
Проверьте осевой зазор
检查轴向间隙

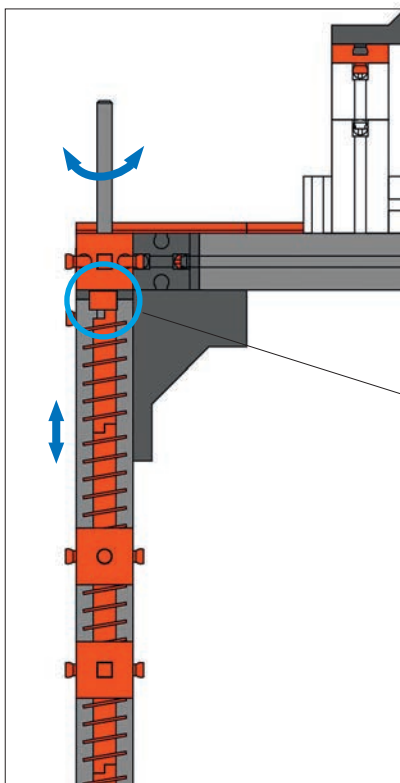
**36a**

Bereich mit den dargestellten Bauteilen so aufbauen, dass kein axiales Spiel mehr vorhanden ist und die Achse leichtgängig gedreht werden kann. Siehe auch www.fischertechnik-elearning.com

Set up the area with the components shown so that no axial backlash is present and the axle can be easily rotated.

Also refer to www.fischertechnik-elearning.com

Monter la zone des éléments de construction reproduits de sorte à exclure le jeu axial et à pouvoir tourner l'axe avec souplesse.

Voir également www.fischertechnik-elearning.com

Bouw de delen met de getoonde onderdelen zodanig op dat er geen axiale speling is en de as soepel draait.

Zie ook www.fischertechnik-elearning.com

Montar la parte con los componentes representados de modo que no haya más juego axial y el eje pueda girarse con suavidad.

Véase también www.fischertechnik-elearning.com

Monte a área com os componentes apresentados de maneira que não haja mais folga e que os eixos possam ser girados com facilidade. Consulte também www.fischertechnik-elearning.com

Assemblare l'area con i componenti raffigurati in modo da escludere qualsiasi gioco assiale e poter ruotare facilmente l'asse.

Vedi anche www.fischertechnik-elearning.com

Соберите показанные детали так, чтобы отсутствовал осевой зазор, и ось могла легко вращаться. См. также www.fischertechnik-elearning.com

用图示的组件构建区域，使轴向间隙消失且轴能够灵活转动。

另见 www.fischertechnik-elearning.com

37

- 4x [Red 1x2 Technic Brick]
- 2x [Red Technic Pin]
- 15 [Red Technic Pin]
- 2x [Red Technic Pin]
- 2x [Red Technic Pin]
- 2x [Red Technic Pin]

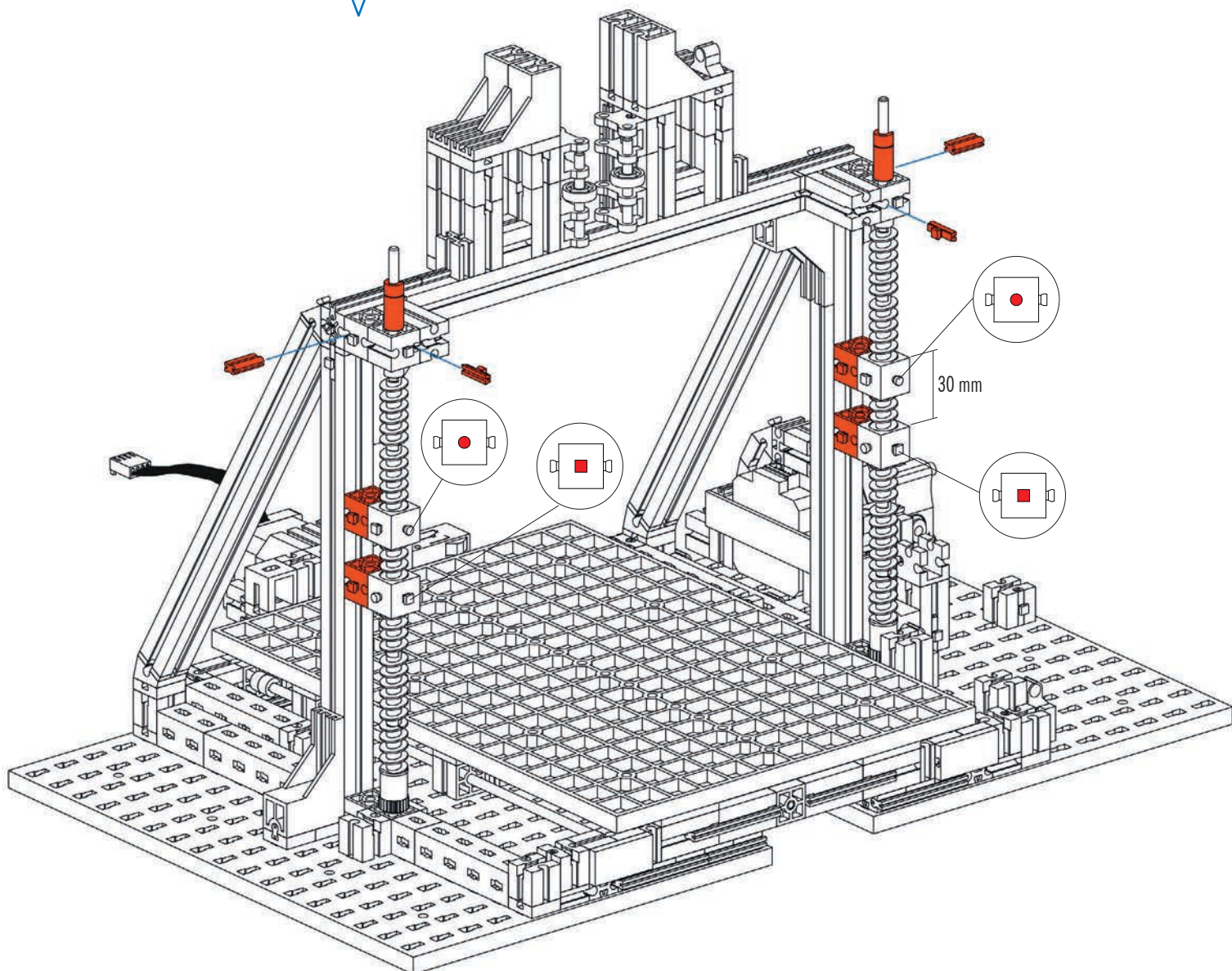

38

- 1x [Grey Motor]
- 1x [Red Motor Mount]
- 4x [Grey Screws]
- 8x [Red Technic Pins]

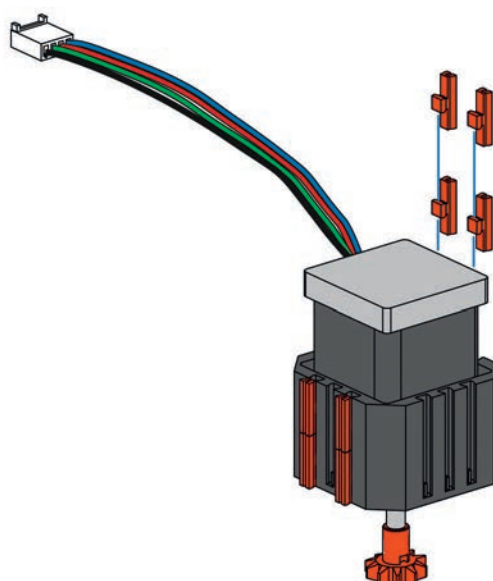

39

2 x

6 x

2 x

1 x

3 x

1 x

2 x

235

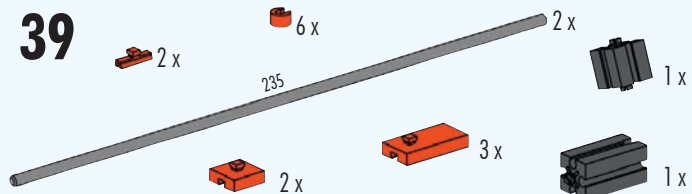

38

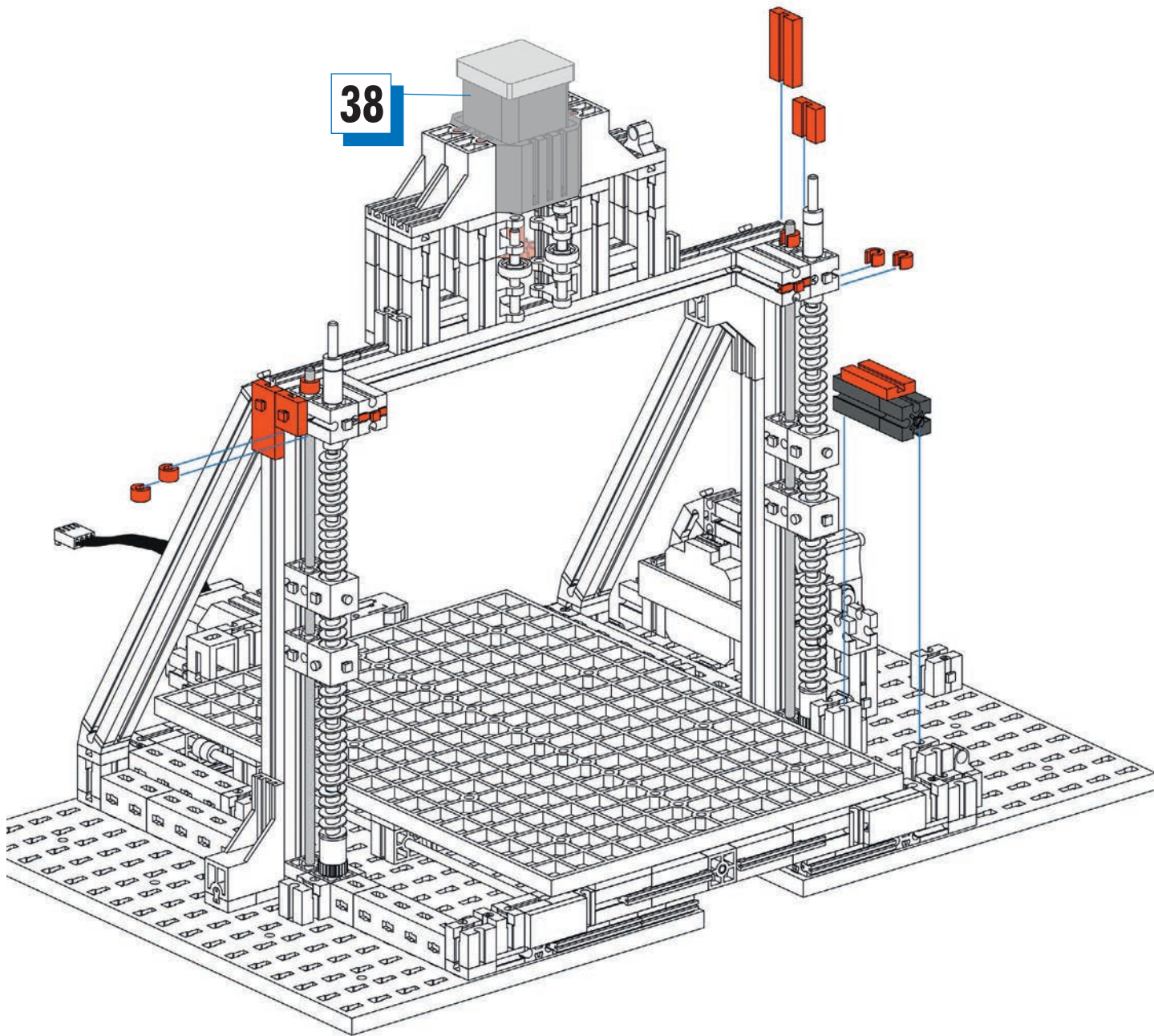

235 mm

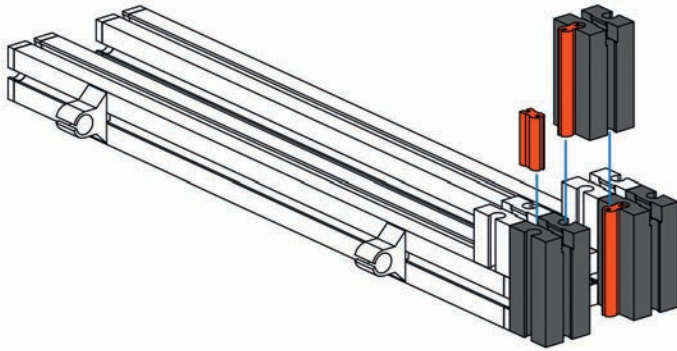
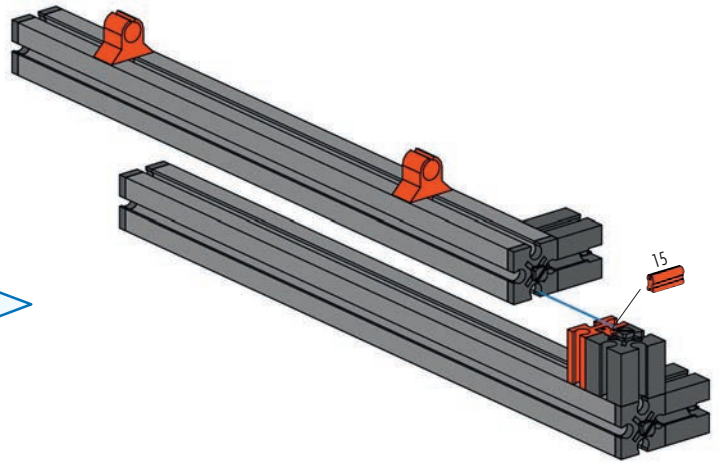
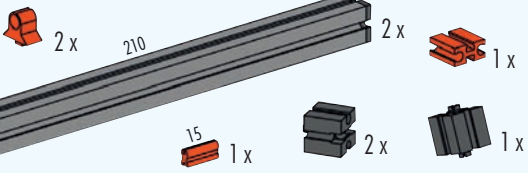
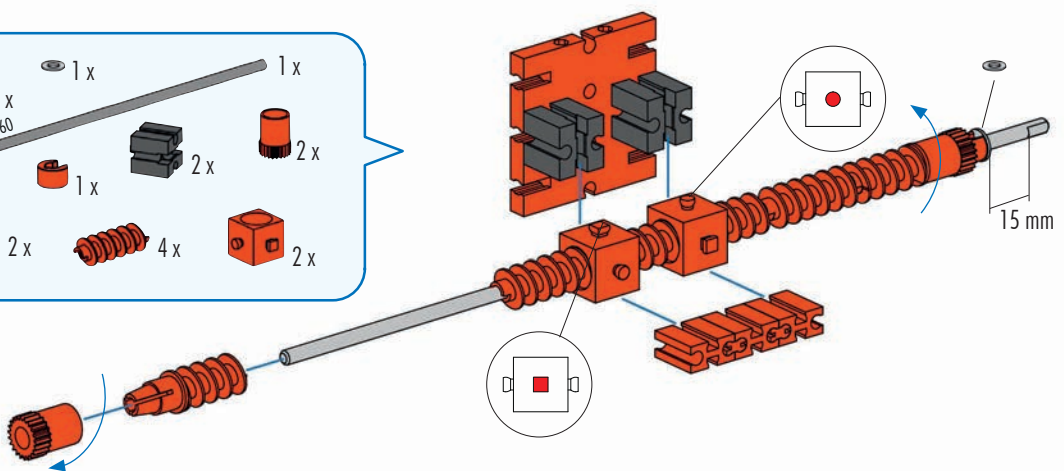
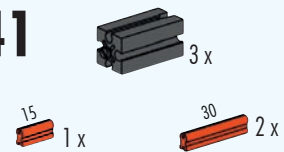
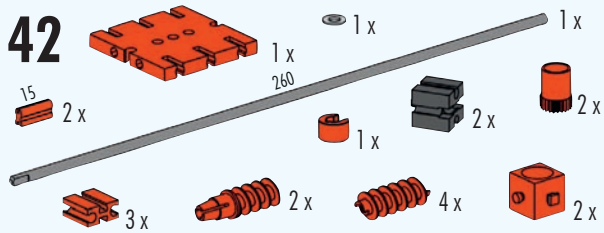
40**41****42**

- Nabenmütern festdrehen
- Fasten the hub nuts home
- Serrer les écrous de moyeu
- Draal de naafmoeren vast
- Atornillar las tuercas laterales
- Apretar bem as porcas de cubo
- Stringere i dadi dei mozzi
- Затянуть гайки ступиц
- 拧紧

260 mm

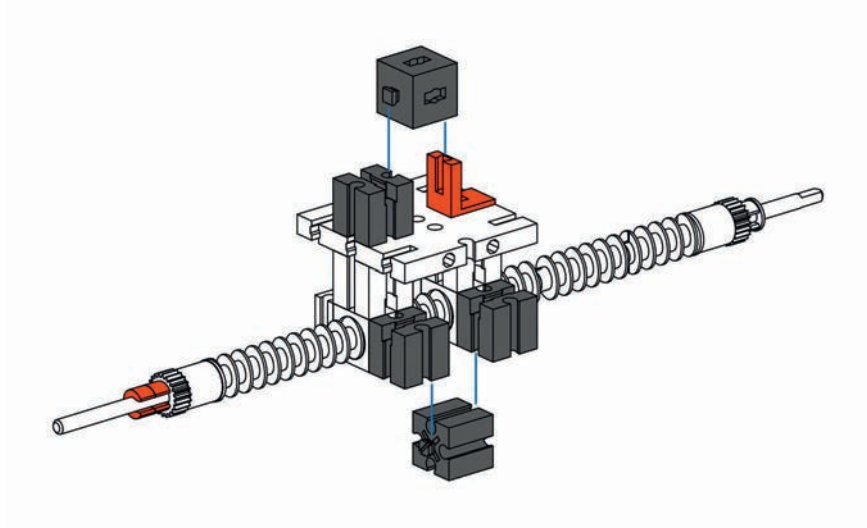

- 43**
- 1 x [Grey Technic Pin]
 - 3 x [Grey Technic Pin]
 - 1 x [Grey Technic Pin]
 - 2 x [Red Technic Pin]
 - 1 x [Red Technic Pin]

- 44**
- 1 x [Grey Technic Pin]
 - 1 x [Grey Technic Pin]
 - 2 x [Red Technic Pin]
 - 2 x [Red Technic Pin]

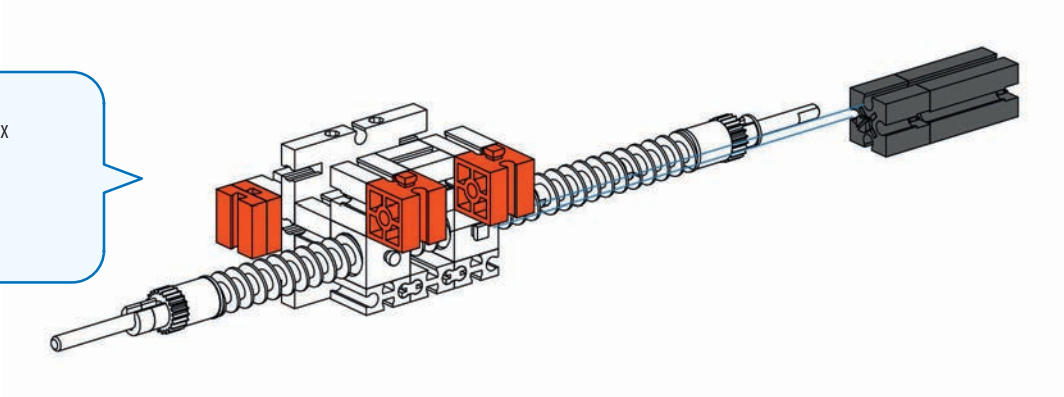

- 45**
- 1 x [Red Technic Pin]
 - 1 x [Red Technic Pin]

44

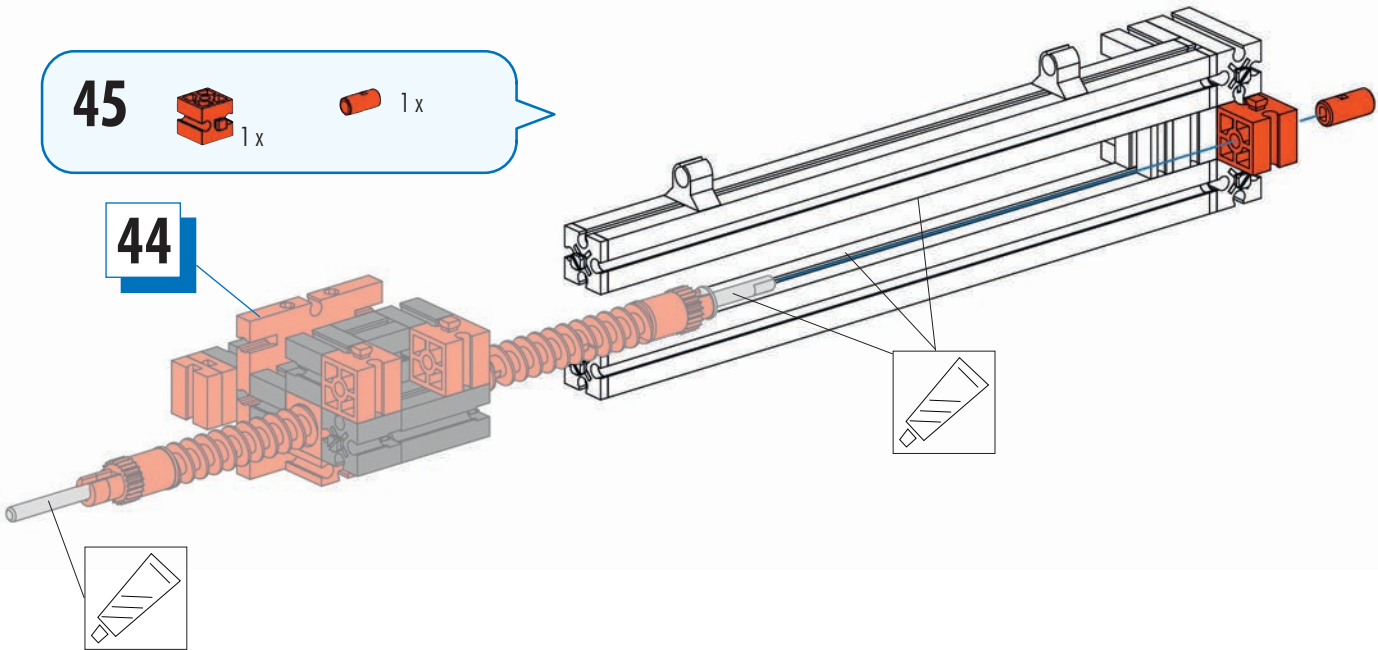

46

- 2x [Black Technic Pin]
- 1x [Black Technic Pin]
- 1x [Black Technic Connector]
- 1x [Red Technic Pin]
- 1x [Red Technic Connector]

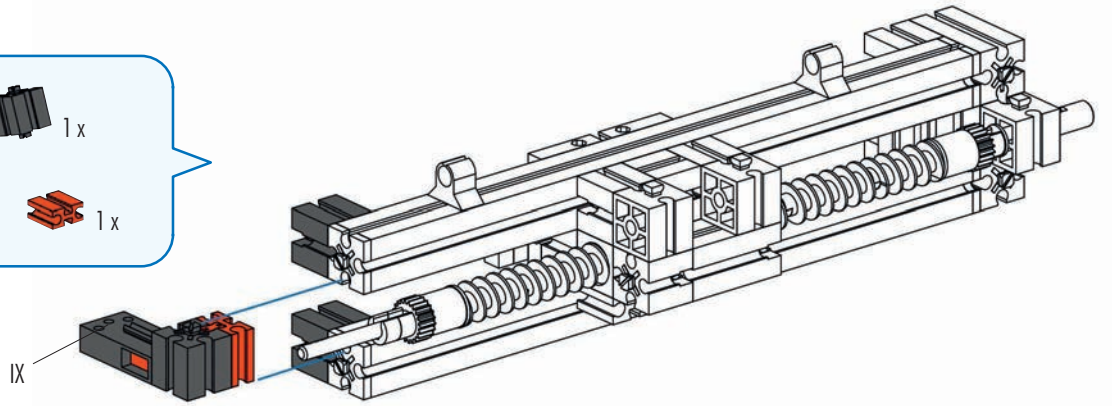

47

- 3x [Black Technic Pin]
- 1x [Red Technic Connector]
- 2x [Red Technic Pin]

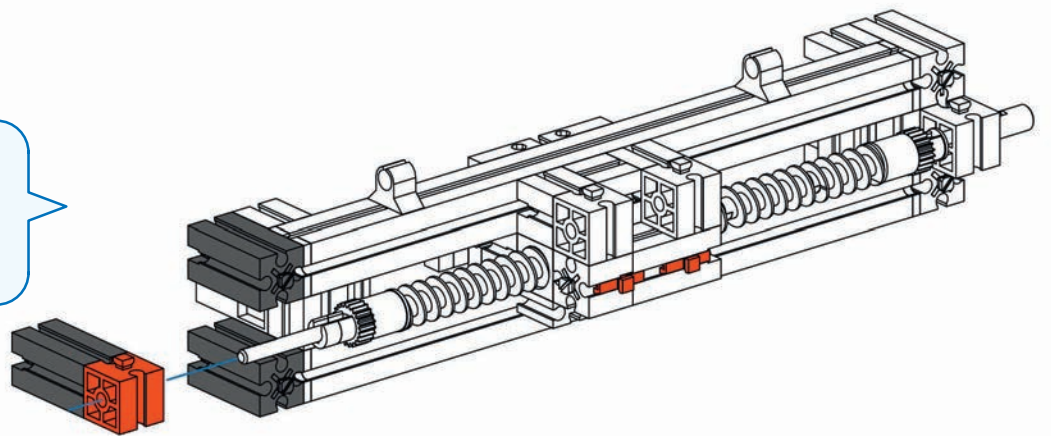

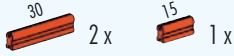
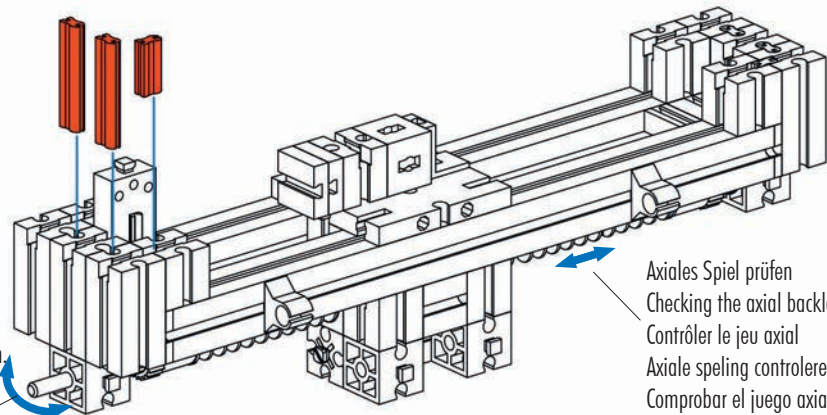
48

 30 2 x 15 1 x

Achse muss leichtgängig gedreht werden können.
 The axle must be easy to rotate.
 La rotation de l'axe doit être souple.
 As moet soepel kunnen draaien.
 El eje debe poder girarse con suavidad.
 O eixo deve girar com facilidade.
 L'asse deve potersi ruotare facilmente.
 Ось должна легко вращаться.
 轴必须能够灵活转动。

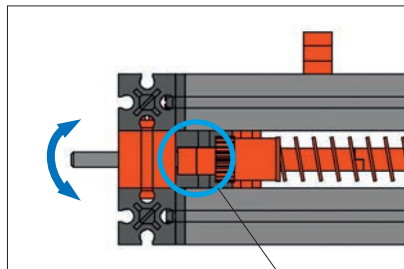
Axiales Spiel prüfen
 Checking the axial backlash
 Contrôler le jeu axial
 Axiale speling controleren
 Comprobar el juego axial
 Verificar folga no eixo
 Controllo del gioco assiale
 Проверьте осевой зазор
 检查轴向间隙

**48a**

Bereich mit den dargestellten Bauteilen so aufbauen, dass kein axiales Spiel mehr vorhanden ist und die Achse leichtgängig gedreht werden kann. Siehe auch www.fischertechnik-elearning.com

Set up the area with the components shown so that no axial backlash is present and the axle can be easily rotated.

Also refer to www.fischertechnik-elearning.com

Monter la zone des éléments de construction reproduits de sorte à exclure le jeu axial et à pouvoir tourner l'axe avec souplesse.

Voir également www.fischertechnik-elearning.com

Bouw de delen met de getoonde onderdelen zodanig op dat er geen axiale speling is en de as soepel draait.

Zie ook www.fischertechnik-elearning.com

Montar la parte con los componentes representados de modo que no haya más juego axial y el eje pueda girarse con suavidad.

Véase también www.fischertechnik-elearning.com

Monte a área com os componentes apresentados de maneira que não haja mais folga e que os eixos possam ser girados com facilidade. Consulte também www.fischertechnik-elearning.com

Assemblare l'area con i componenti raffigurati in modo da escludere qualsiasi gioco assiale e poter ruotare facilmente l'asse.

Vedi anche www.fischertechnik-elearning.com

Vedi anche www.fischertechnik-elearning.com

Соберите показанные детали так, чтобы отсутствовал осевой зазор, и ось могла

легко вращаться. См. также www.fischertechnik-elearning.com

用图示的组件构建区域，使轴向间隙消失且轴能够灵活转动。

另见www.fischertechnik-elearning.com

49

4 x

3 x

2 x

2 x

2 x

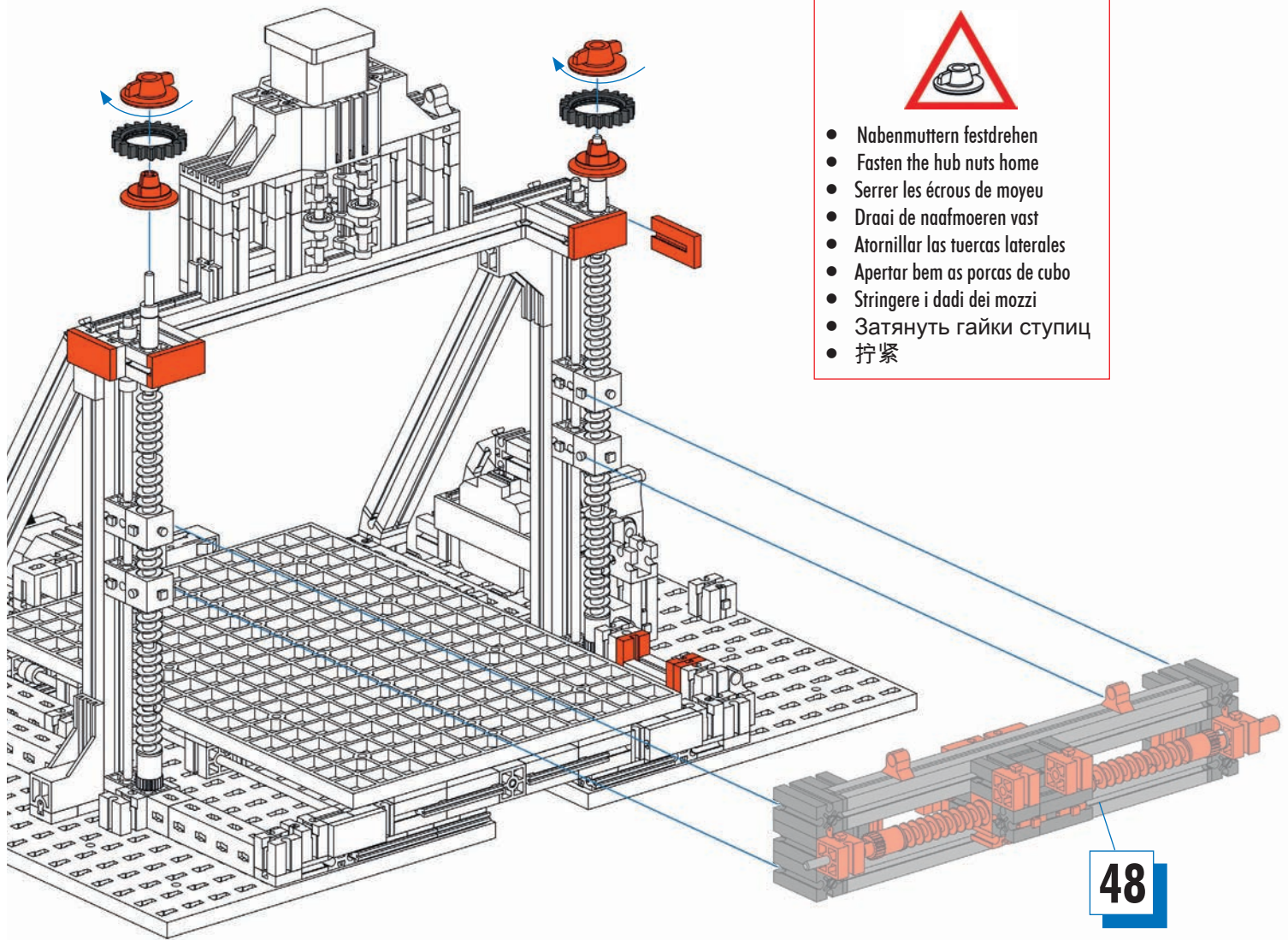

- Nabenmuttern festdrehen
- Fasten the hub nuts home
- Serrer les écrous de moyeu
- Draai de naafmoeren vast
- Atornillar las tuercas laterales
- Apertar bem as porcas de cubo
- Stringere i dadi dei mozzi
- Затянуть гайки ступиц
- 拧紧

48

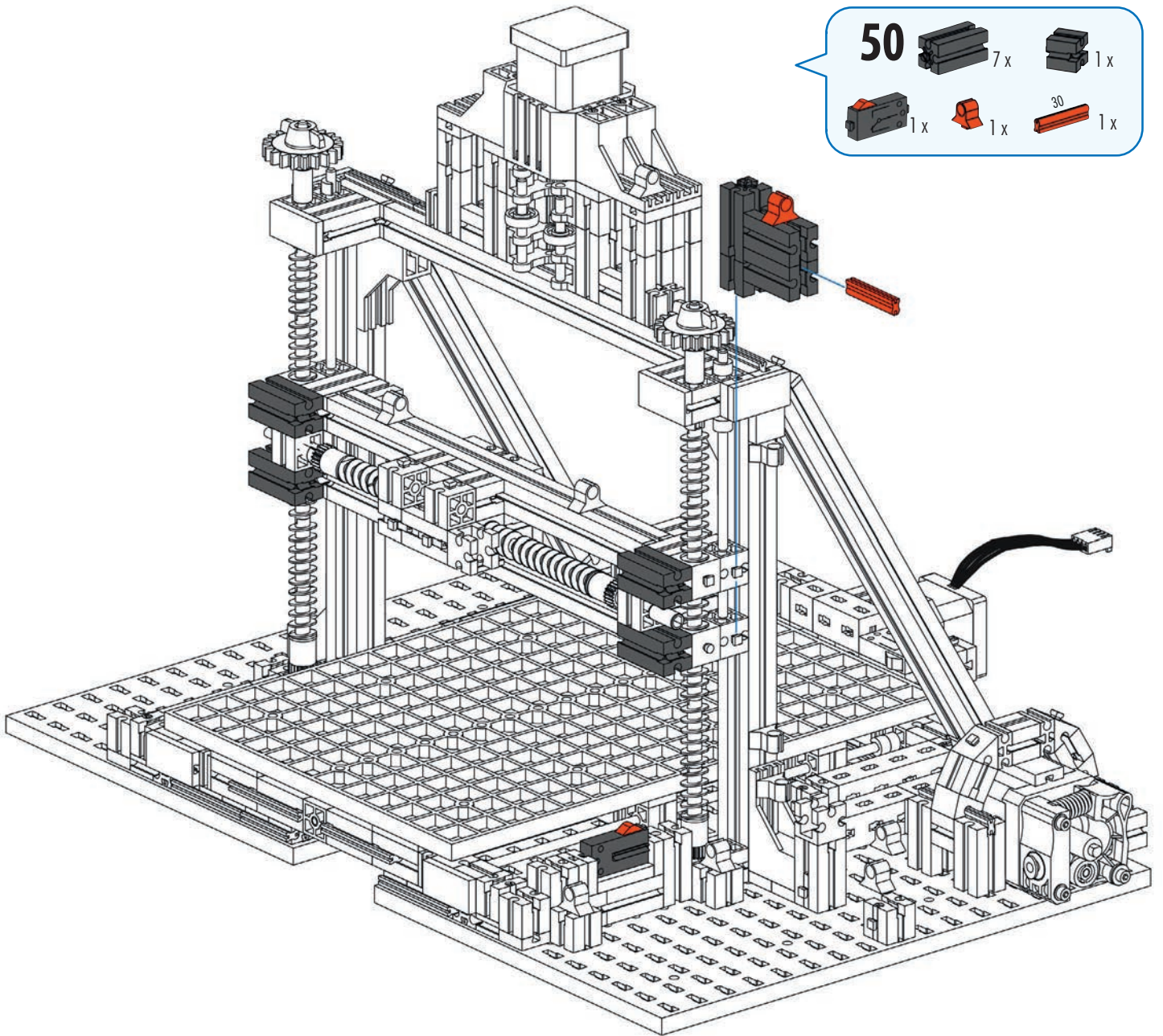



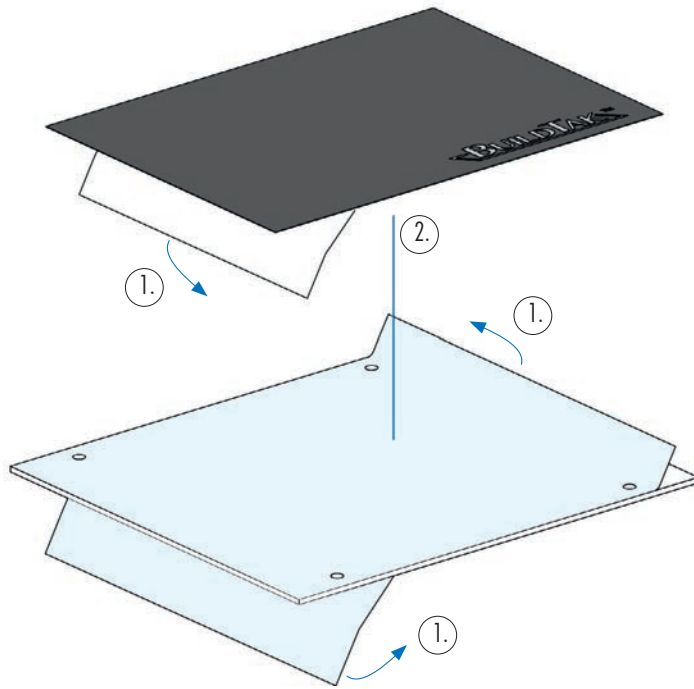
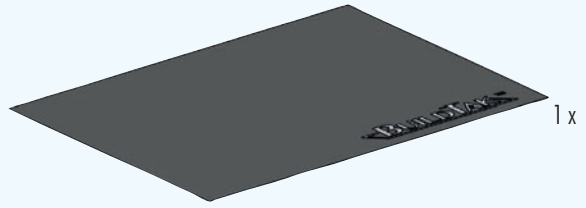
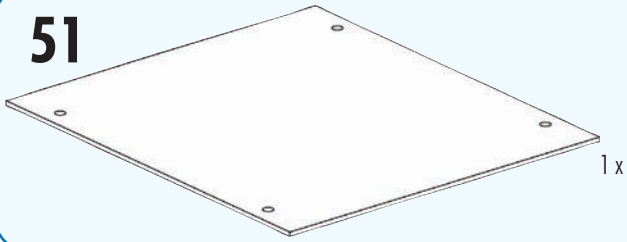



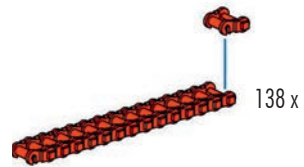

51



52

 138 x

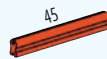

- 53**  2 x  2 x  1 x  2 x  1 x  4 x  4 x  2 x

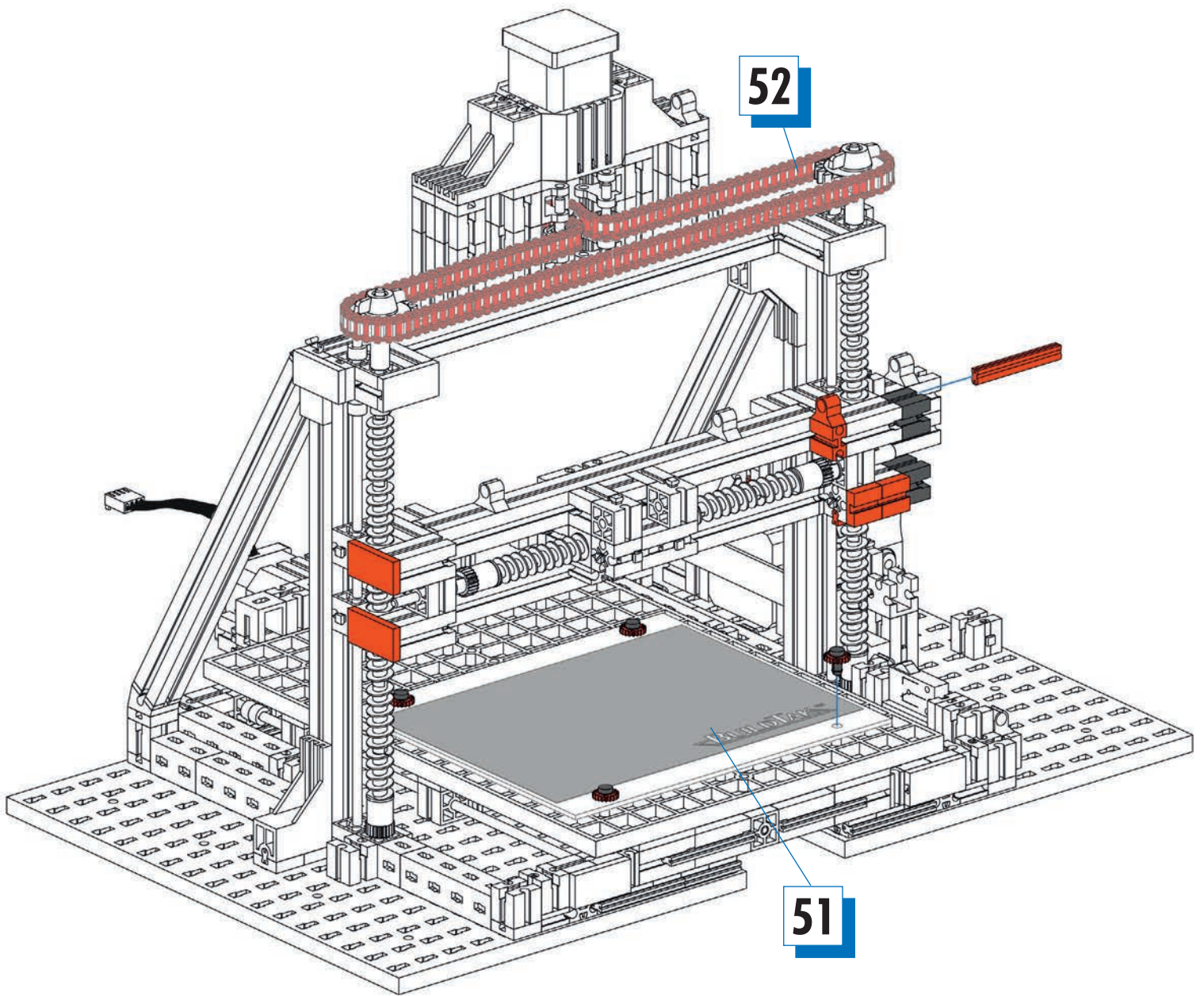

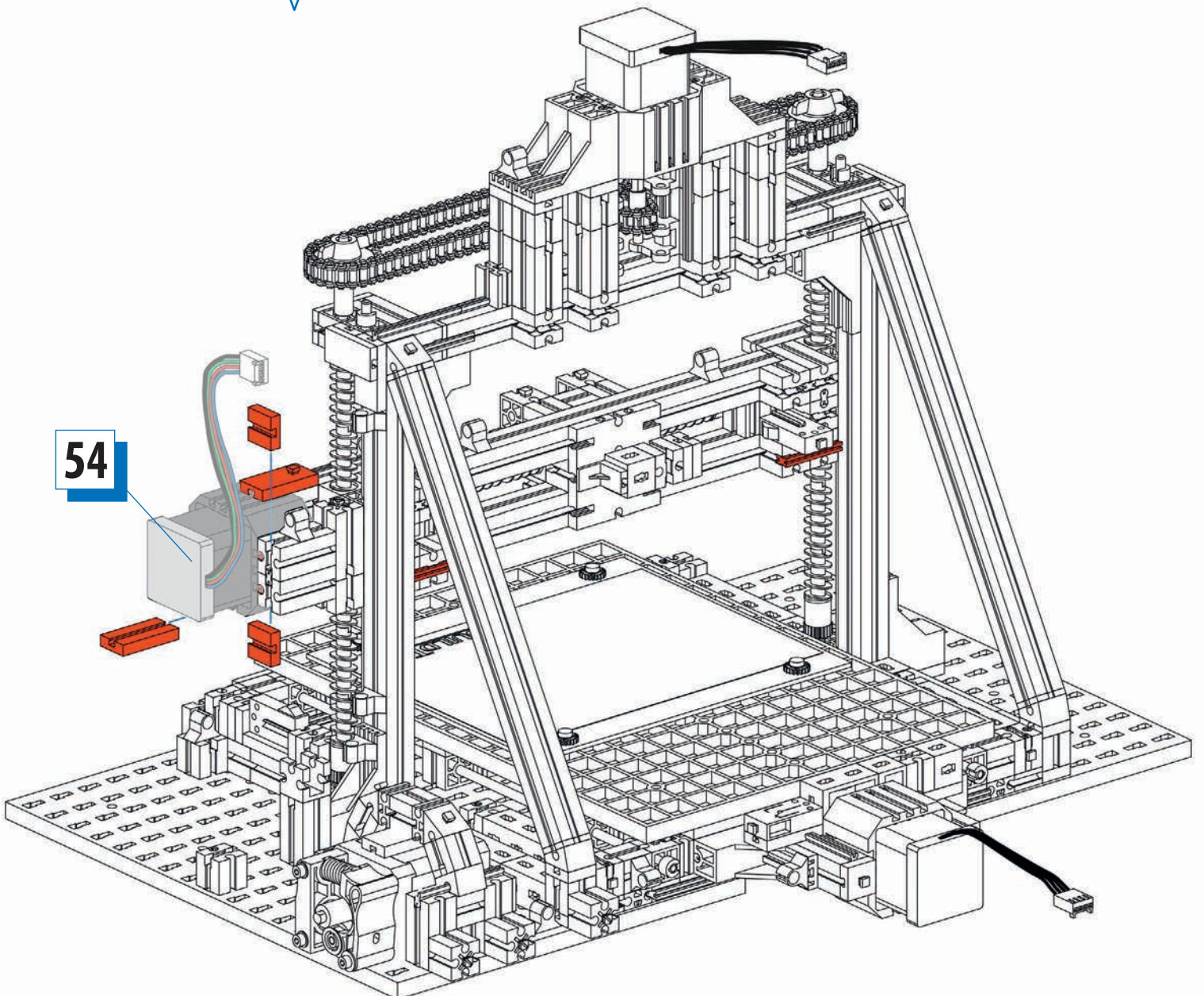
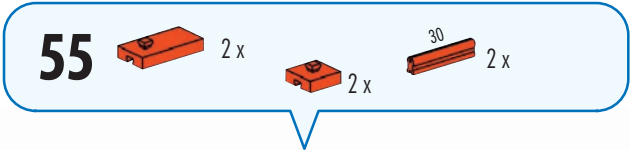
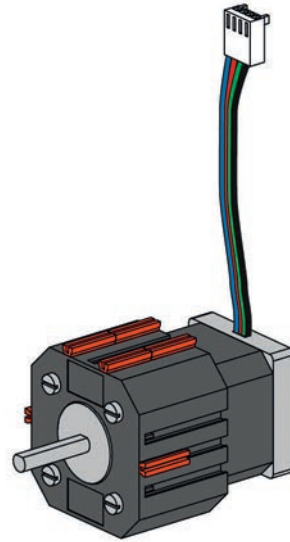
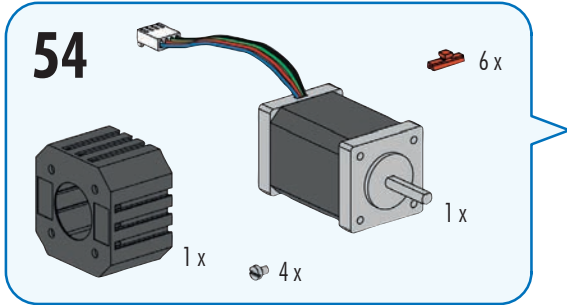

56

- 110 1x
- 2x
- 2x
- 2x
- 1x
- 1x
- 2x

110 mm

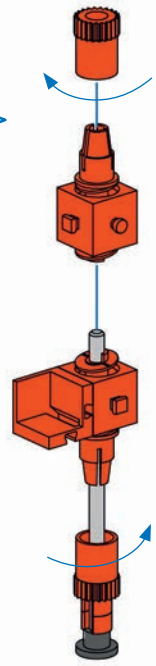

- Nabenmutter festdrehen
- Fasten the hub nuts home
- Serrer les écrous de moyeu
- Draal de naafmoeren vast
- Atornillar las tuercas laterales
- Apertar bem as porcas de cubo
- Stringere i dadi dei mozzi
- Затянуть гайки ступиц
- 拧紧

57

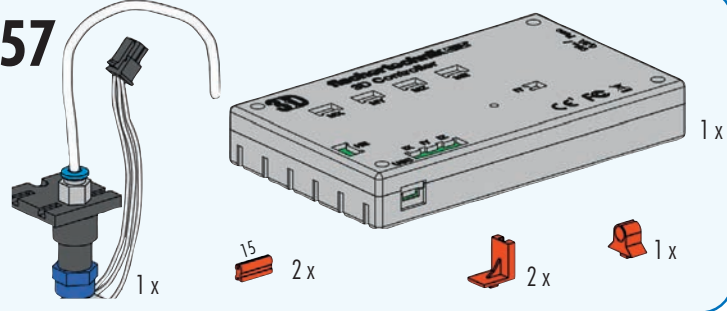





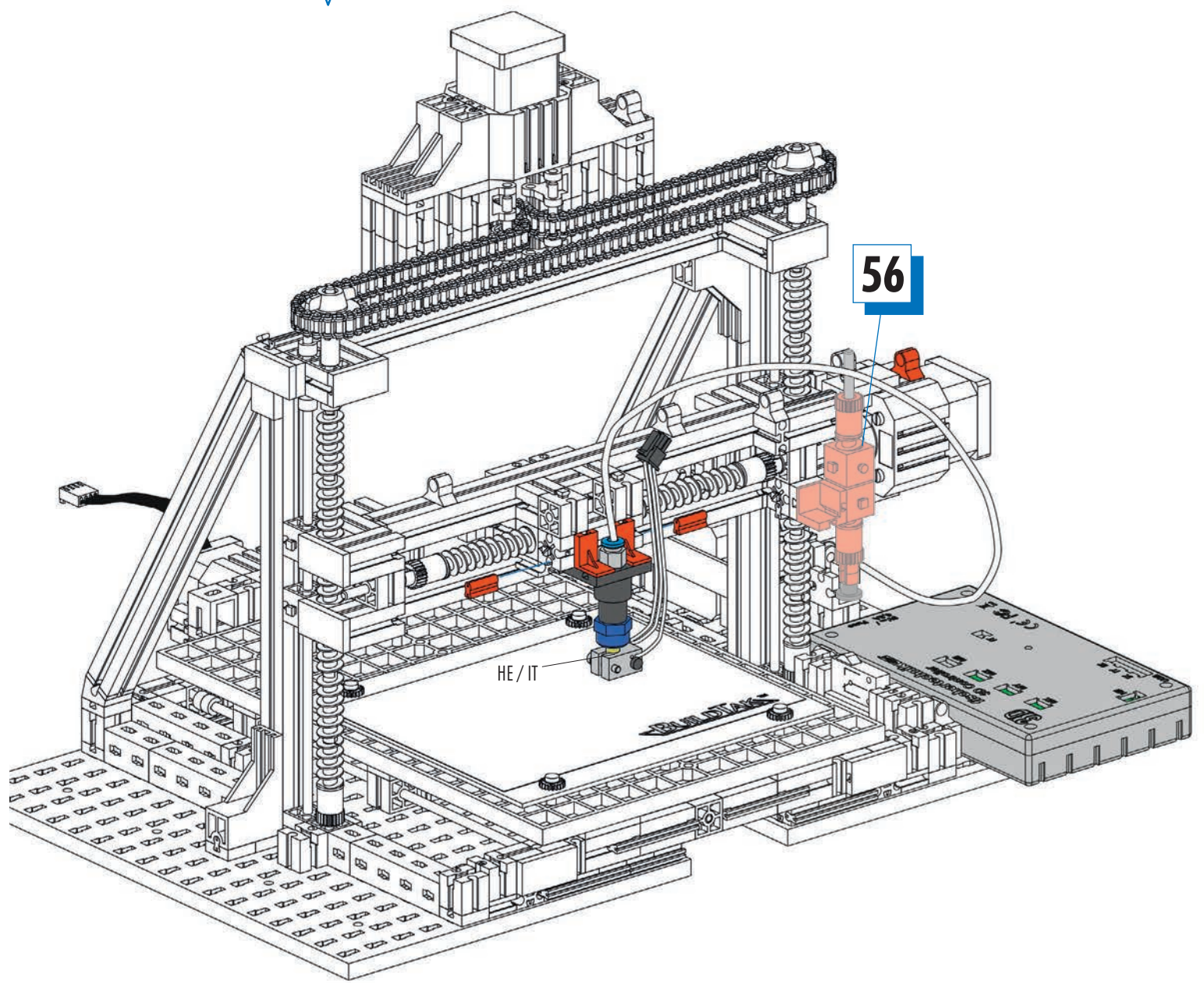





- 15 2x
- 2x
- 1x

56



58



 2x
  2x
  2x
 1x
 2x
 1x
 1x



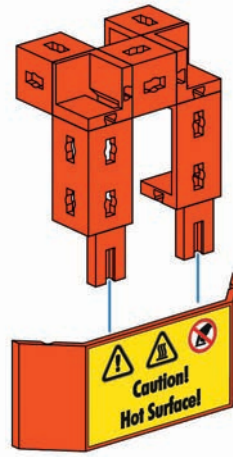

Caution!
Hot Surface!

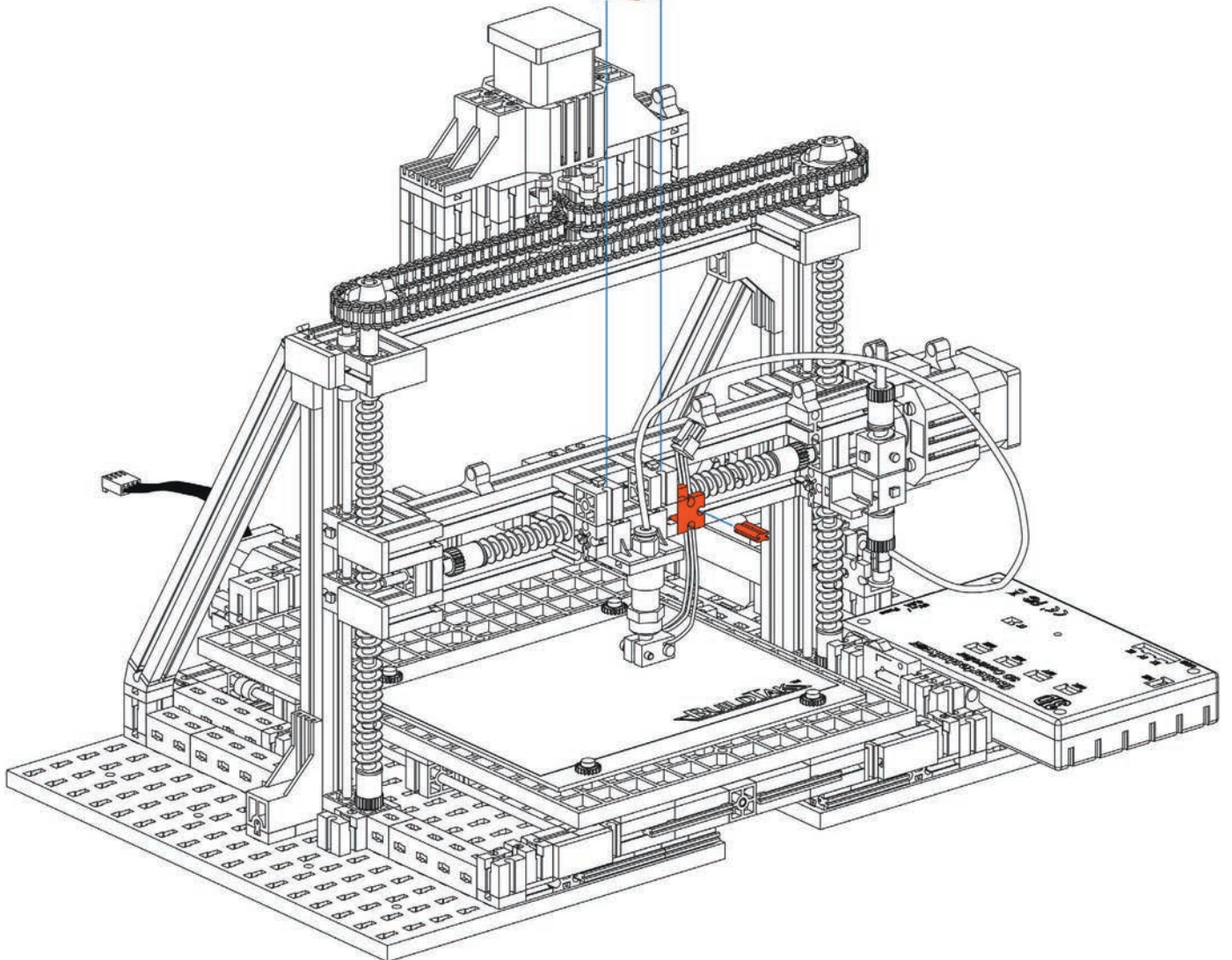
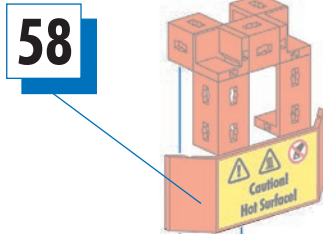

59

 1x
 1x



60

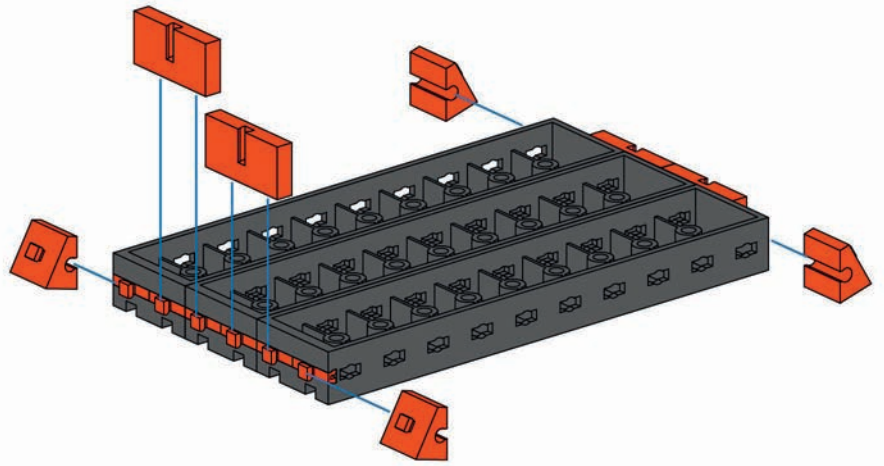
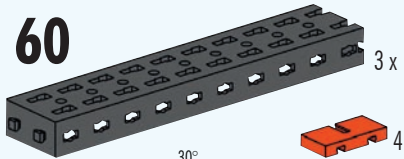

61

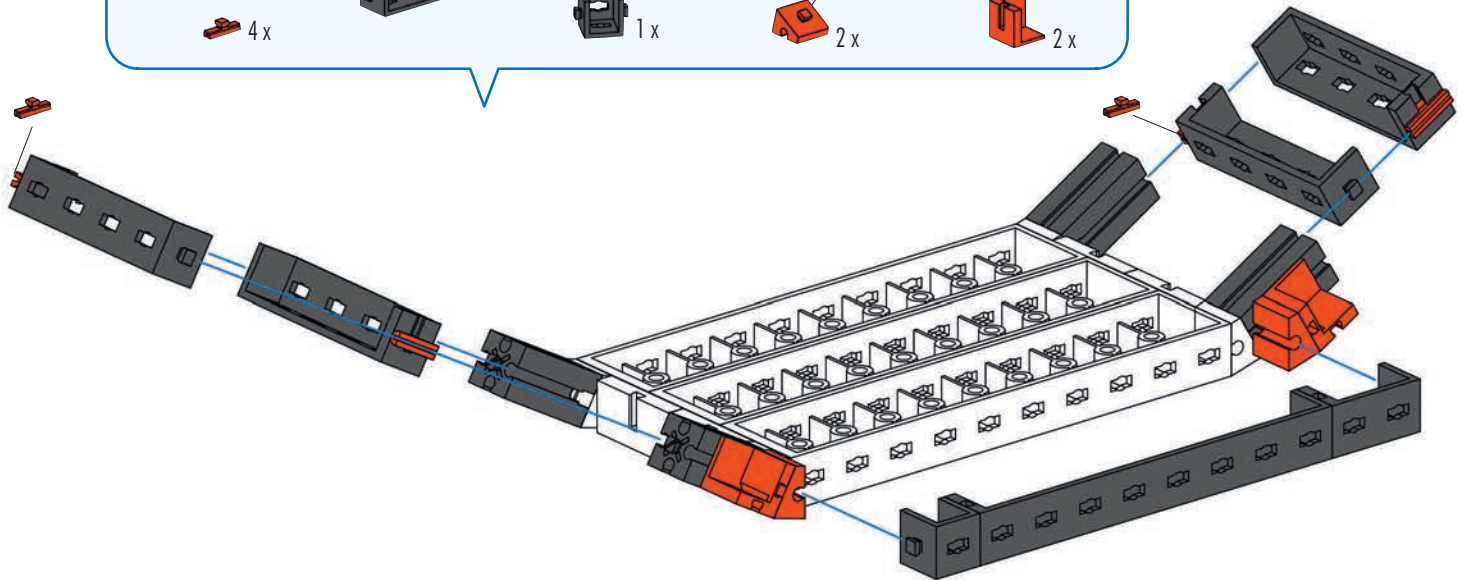
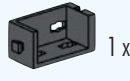
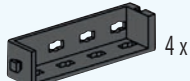
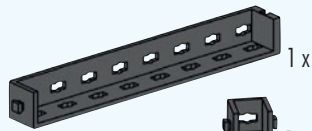
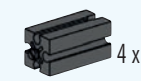

62

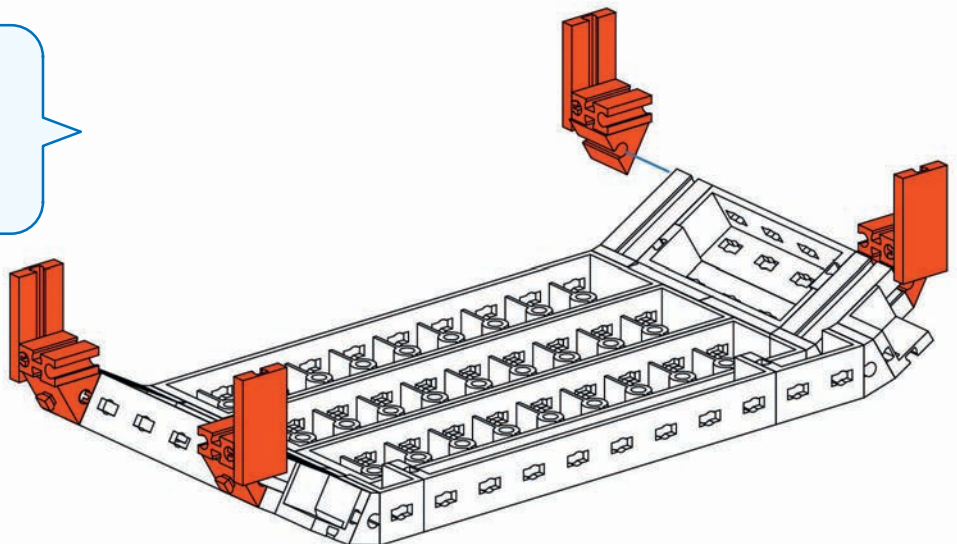

63

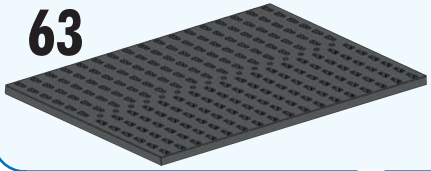

1 x

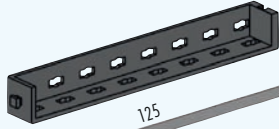

4 x



1 x



4 x



4 x



2 x



2 x



3 x



2 x



2 x

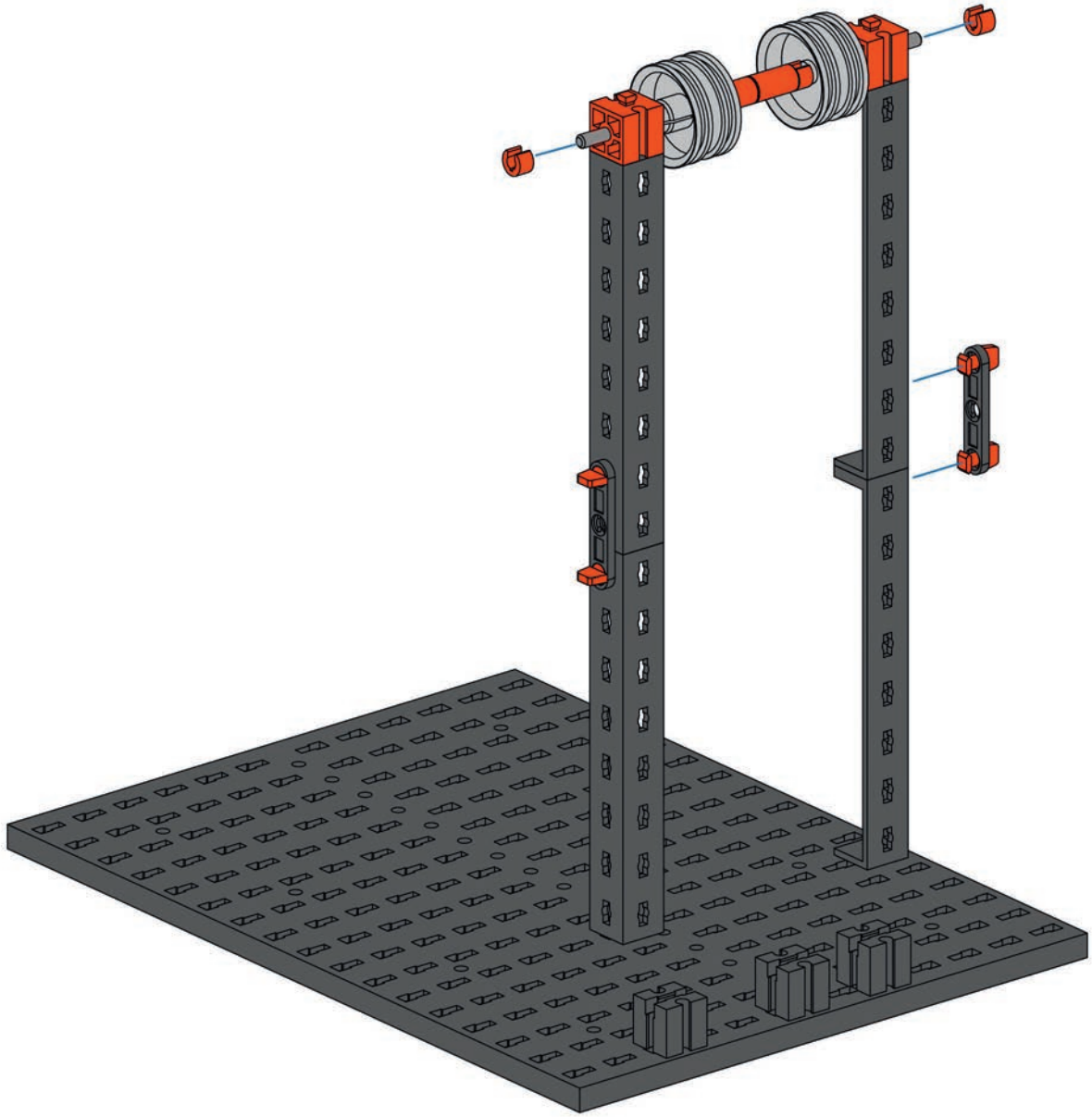

63

64
15
1 X

62

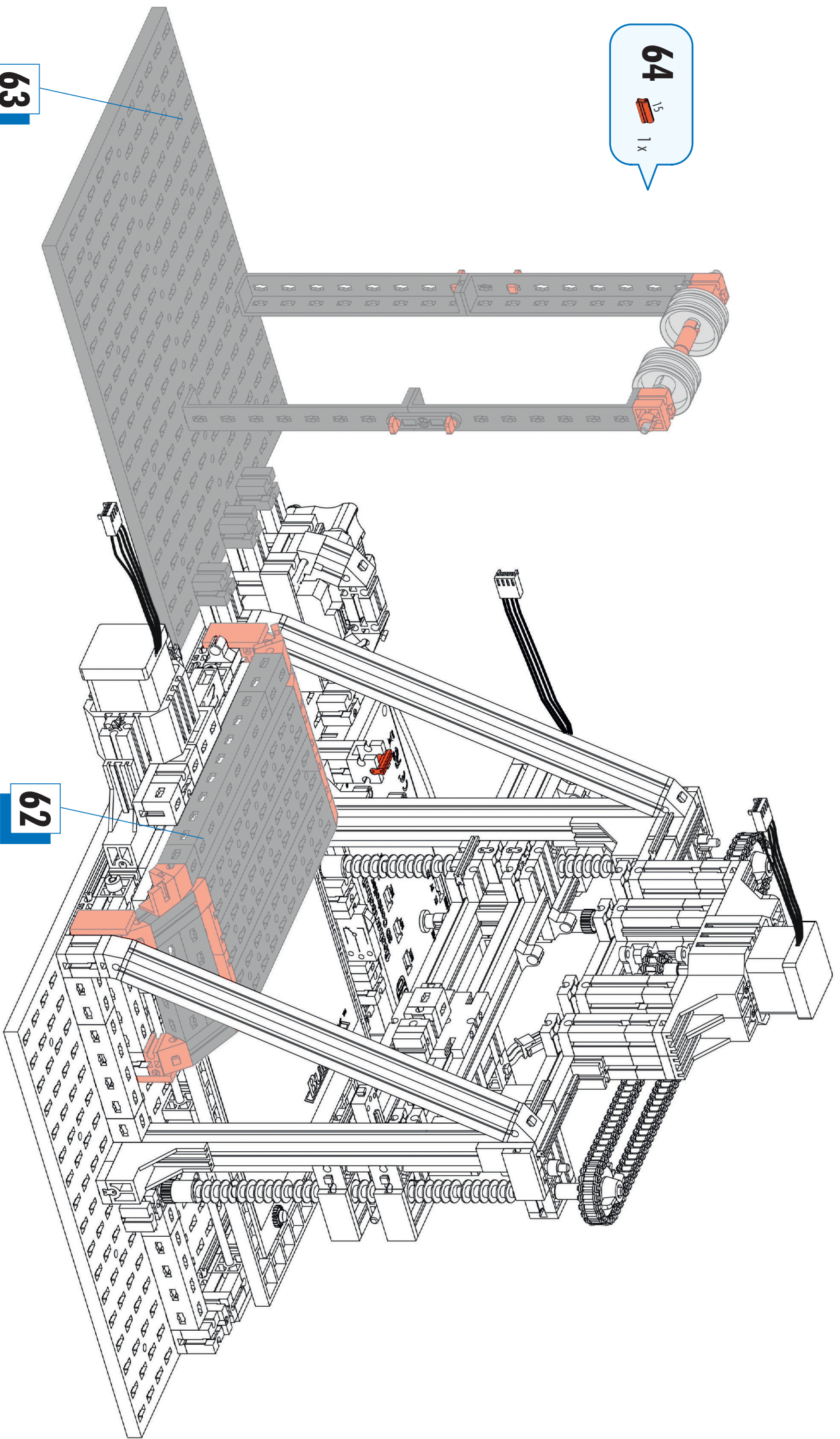

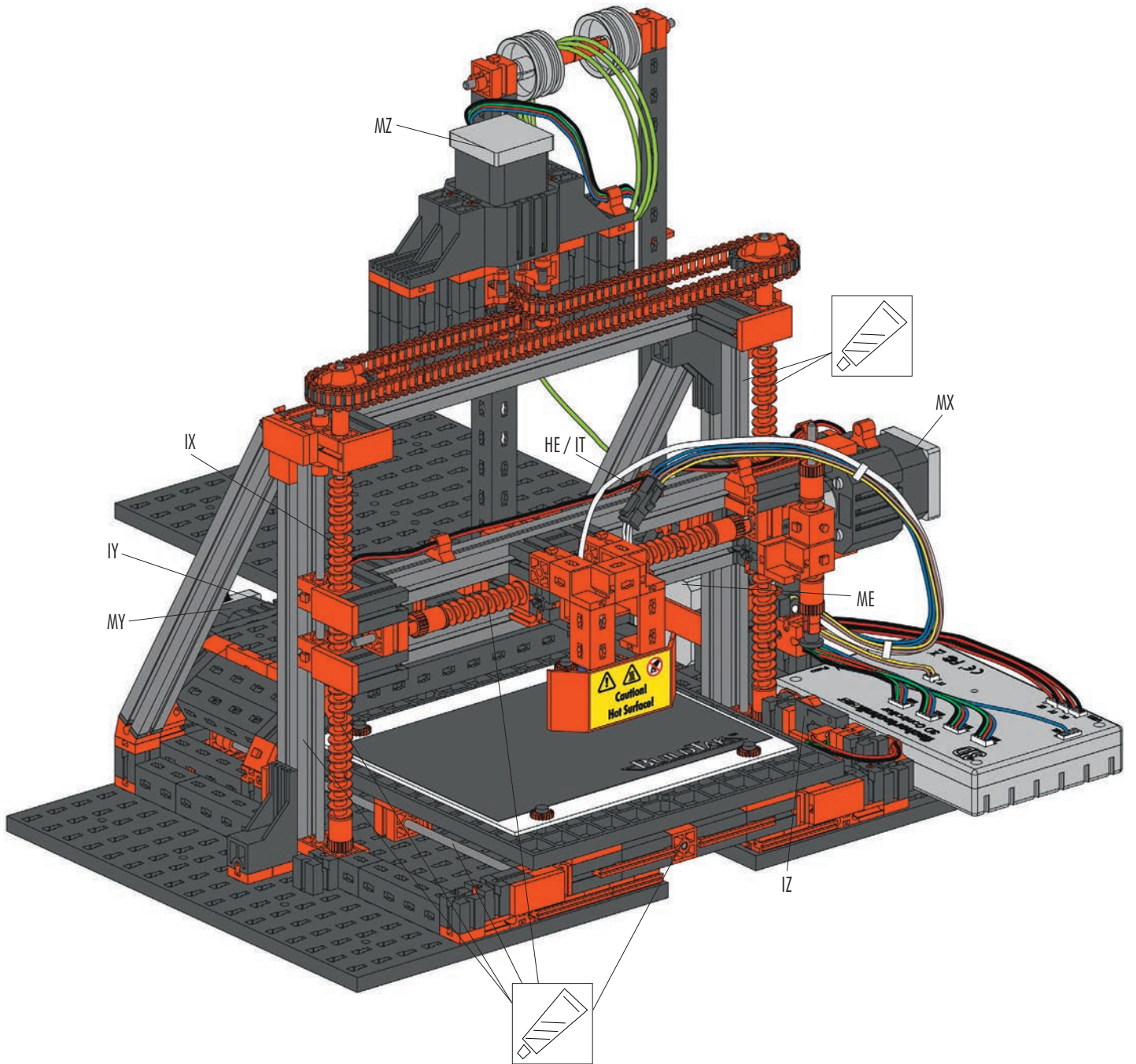

Schaltplan
 Circuit diagram
 Plan électrique

Schakelschema
 Diagrama de circuitos
 Plano elétrico de ligação

Schema elettrico
 Схема подключения
 电路图

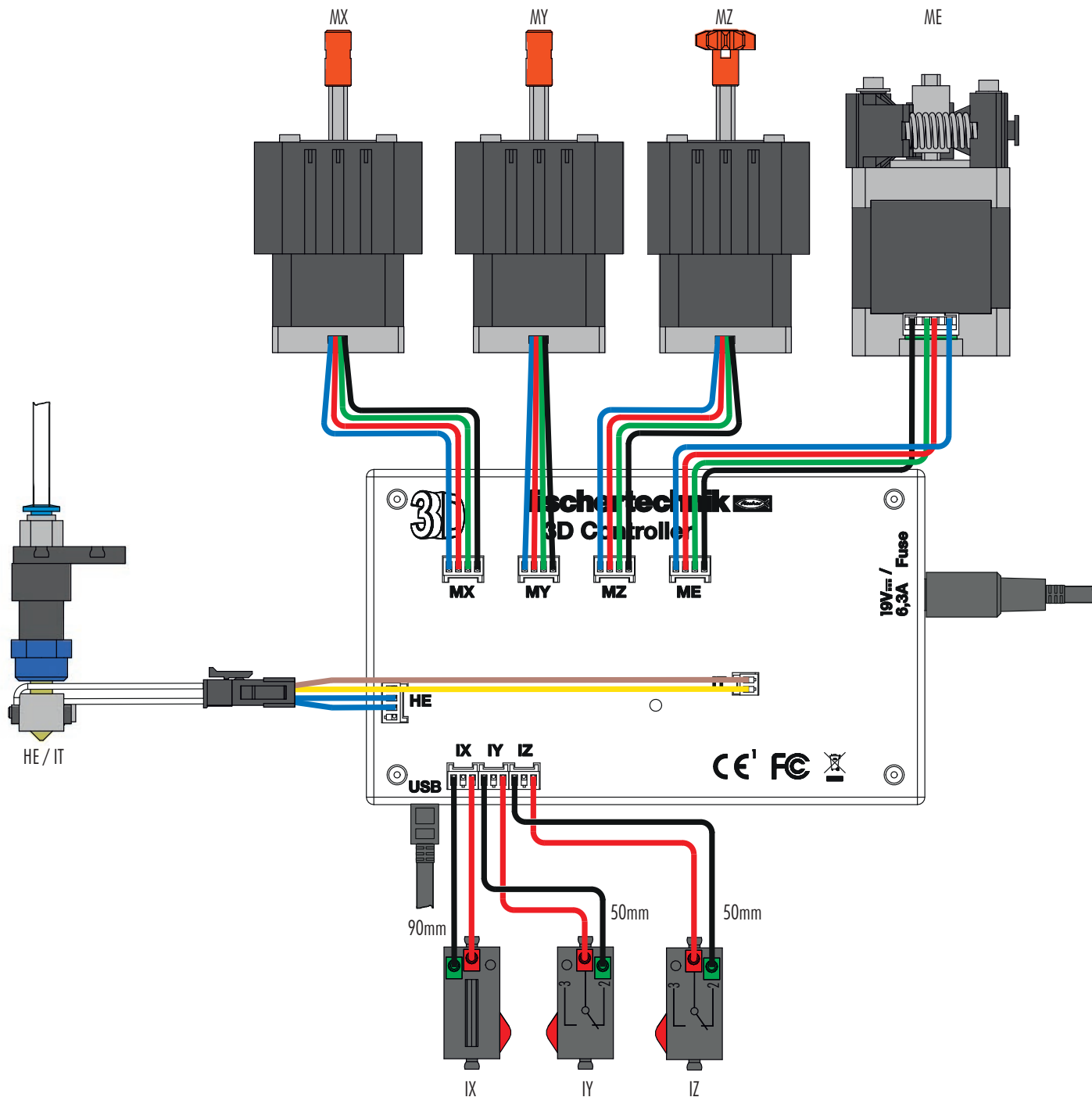

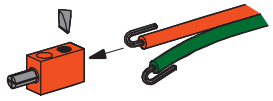
<p>Kabel und Stecker Plugs and cables Fiches et des câbles</p>	<p>Stekkers en cables Enchufes en cables Cabos e contatos</p>	<p>Cavi e connettori Провода и штекеры 电缆和插头</p>	 <p>3 x</p>
--	---	--	---

Halterung Filamentspule
Filament spool holder
Support de la bobine de filament

Houder filamentspoel
Soporte para bobinas de filament
Soporte da bobina de filament

Supporto bobina del filament
Держатель катушки филамента
打印线材盘卷支架

Für fischertechnik Premium Filament 500g Spule. In verschiedenen Farben erhältlich.
Filamentspule nicht im Baukasten enthalten.
For the fischertechnik Premium Filament 500g coil. Available in a variety of colors.
The filament coil is not included in the construction set.
Pour la bobine de filament premium fischertechnik de 500 g. Disponible dans différents coloris.
La bobine de filament n'est pas comprise dans la boîte de construction.
Voor fischertechnik Premium Filament 500g spoel. In verschillende kleuren leverbaar.
Filamentspoel niet bij de bouwdoos inbegrepen.
Para bobina de filament fischertechnik Premium de 500 g. Disponible en diferentes colores.
Bobina de filament no incluida en el kit de construcción.
Para bobina de 500 g de filament Premium fischertechnik. Disponível em diversas cores.
Bobina de filament não incluída no módulo.
Per la bobina di filament fischertechnik premium da 500 g. Disponibile in vari colori.
La bobina del filament non è contenuta nel set di costruzione.
Для катушки филамента fischertechnik Premium 500г. Имеется различного цвета. Катушка филамента не содержится в комплекте.
用于慧鱼 (fischertechnik) 顶级打印线材 500g 盘卷。可购买不同的颜色。打印线材盘卷不包含在标准构件中

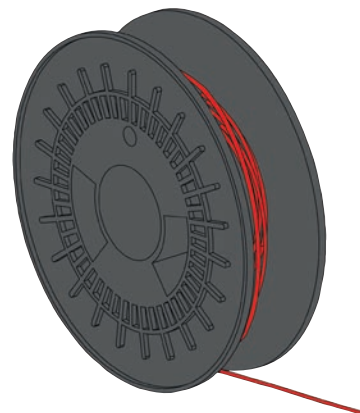

1

- 1 x [Large dark grey base plate]
- 4 x [Long dark grey beam]
- 4 x [Orange corner bracket]
- 3 x [Black pin]
- 2 x [Orange pin]
- 4 x [Red pin]
- 2 x [Black pin 30]

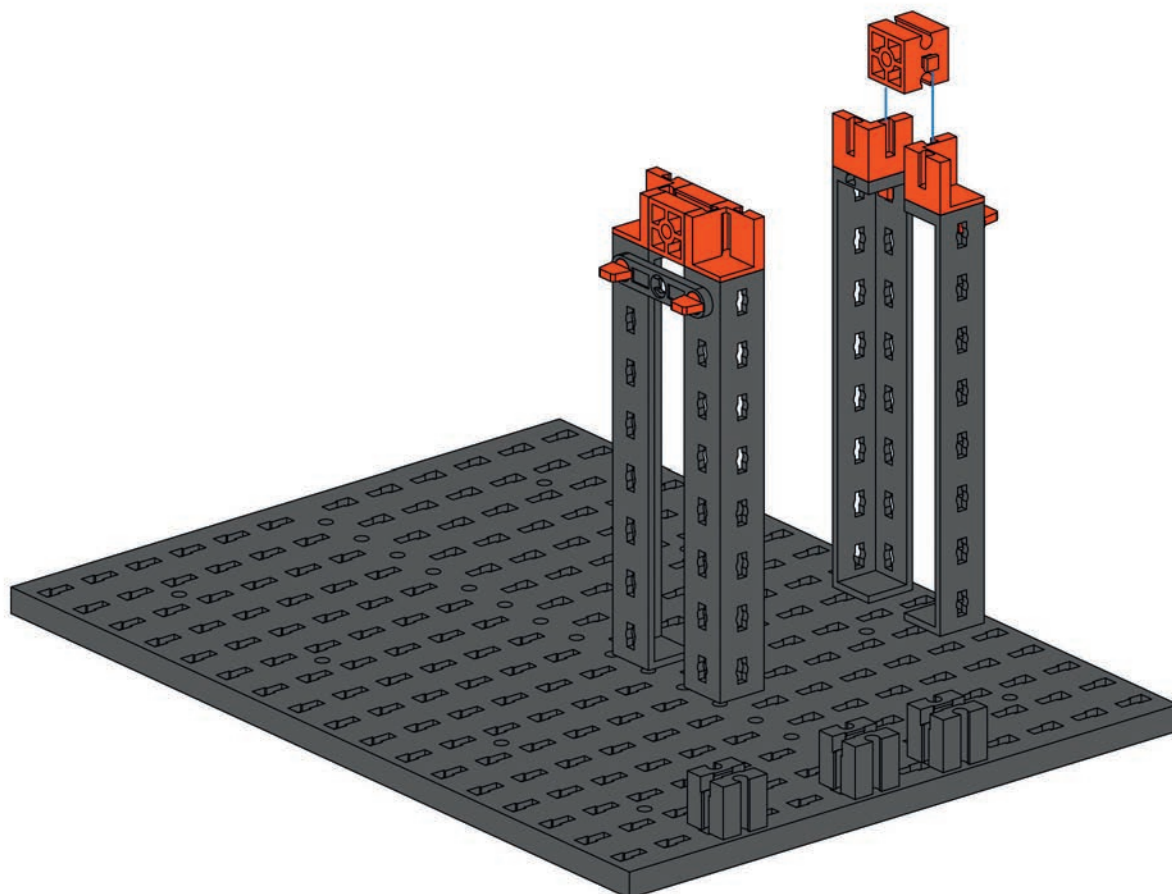

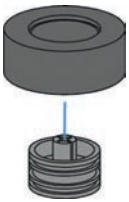
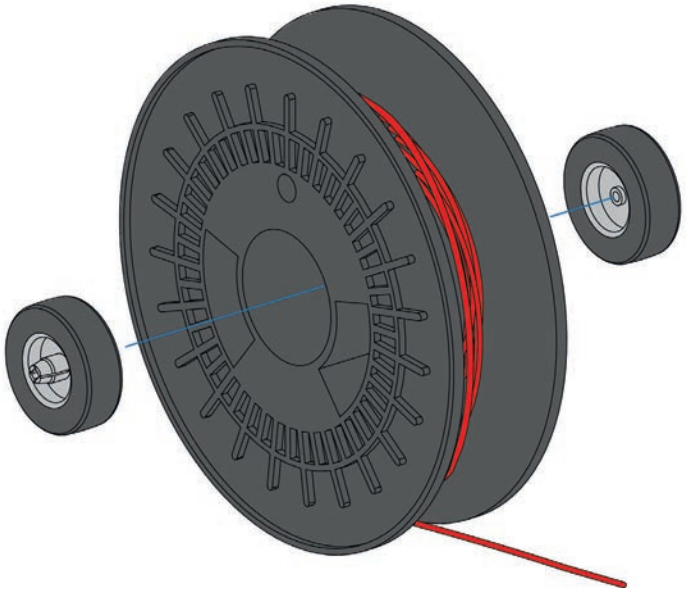
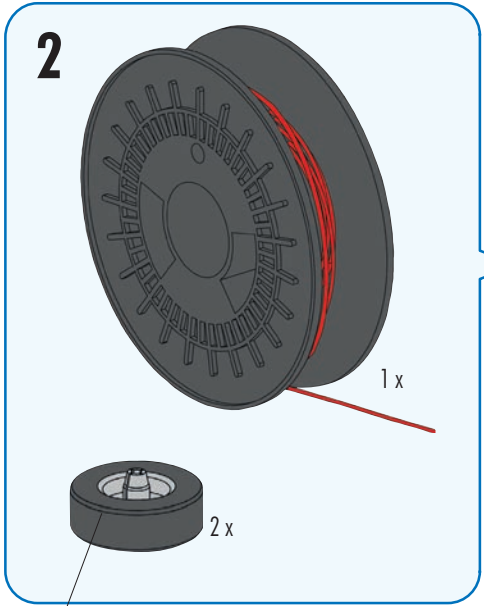

2

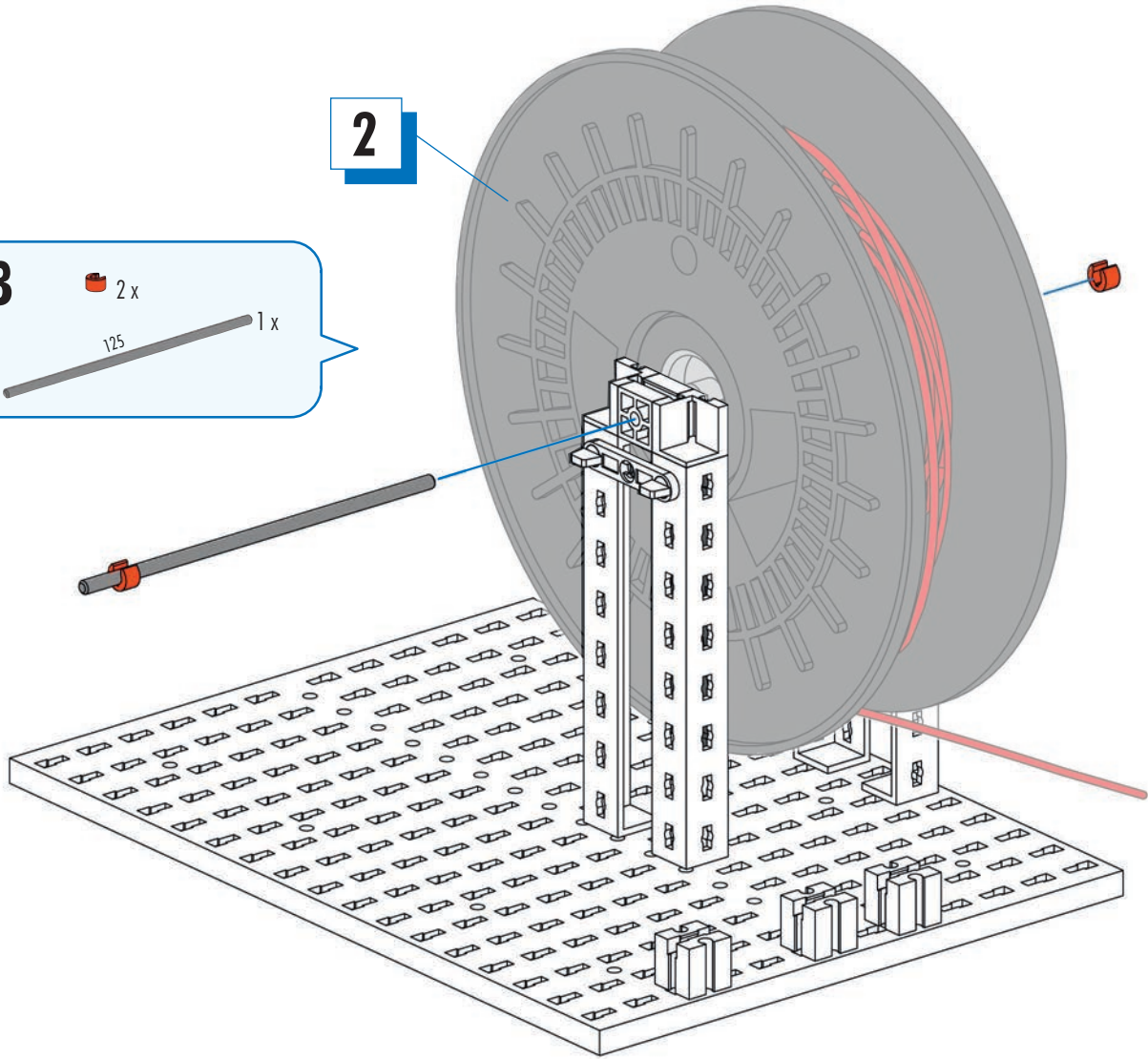
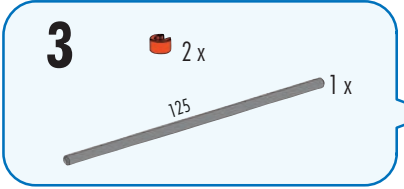

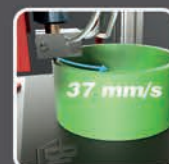
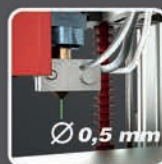

fischertechnik

fischertechnik GmbH
Klaus-Fischer-Str. 1
72178 Waldachtal
Germany

Phone: +49 74 43/12-43 69

Fax: +49 74 43/12-45 91

info@fischertechnik.de

www.fischertechnik.de

3D

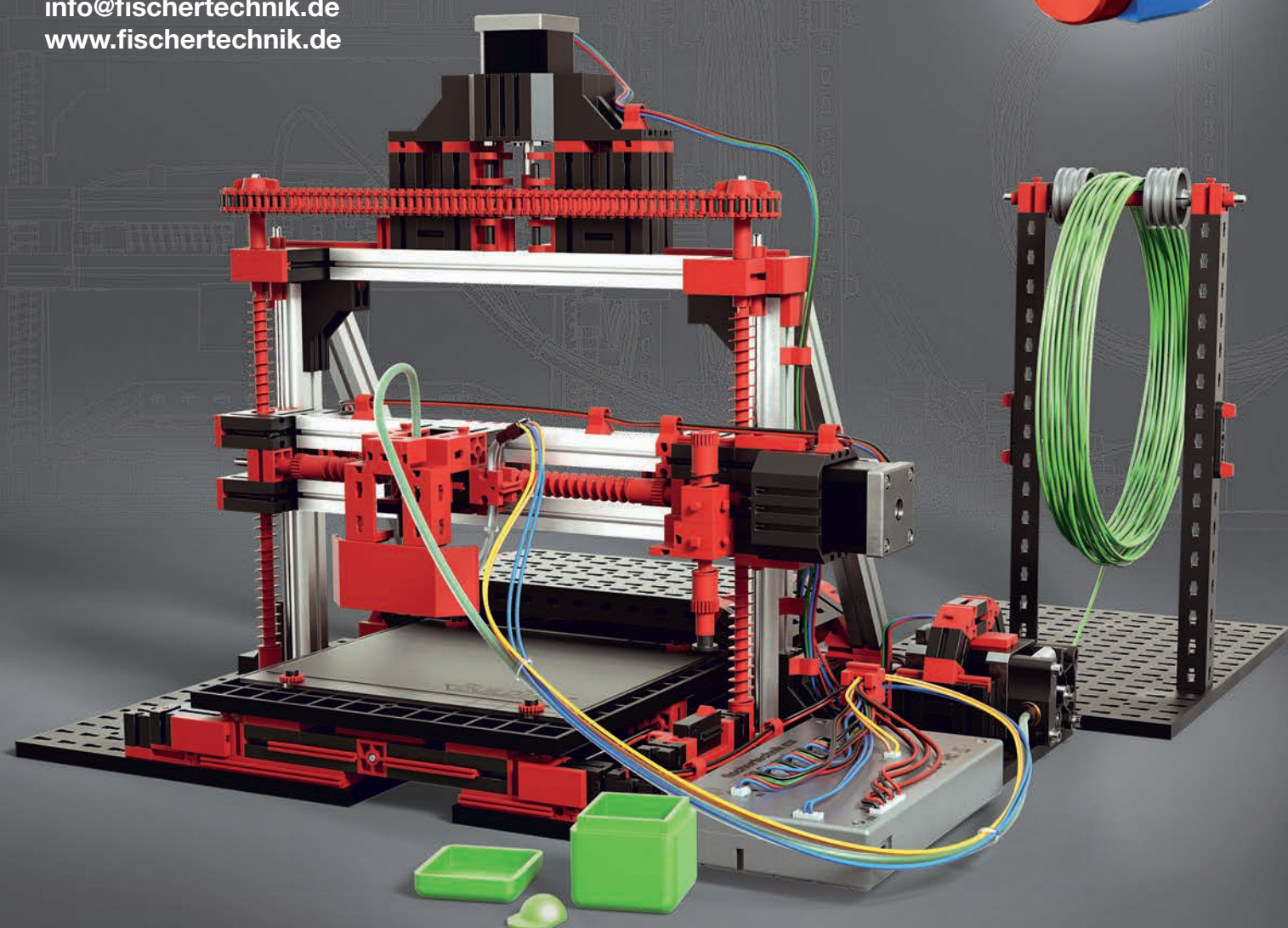

3D Printer

powered by

German
RepRap

