



**fischertechnik** 

**ROBOTICS**

Bauanleitung  
Assembly instruction  
Instructions de montage  
Bouwhandleiding  
Instrucciones de construcción  
Manual de montagem  
Istruzioni di montaggio  
Инструкция по сборке  
安装说明书

**Didactic Information**  
[www.fischertechnik-eLearning.com](http://www.fischertechnik-eLearning.com)  
**free download** 

 **eLearning Portal**

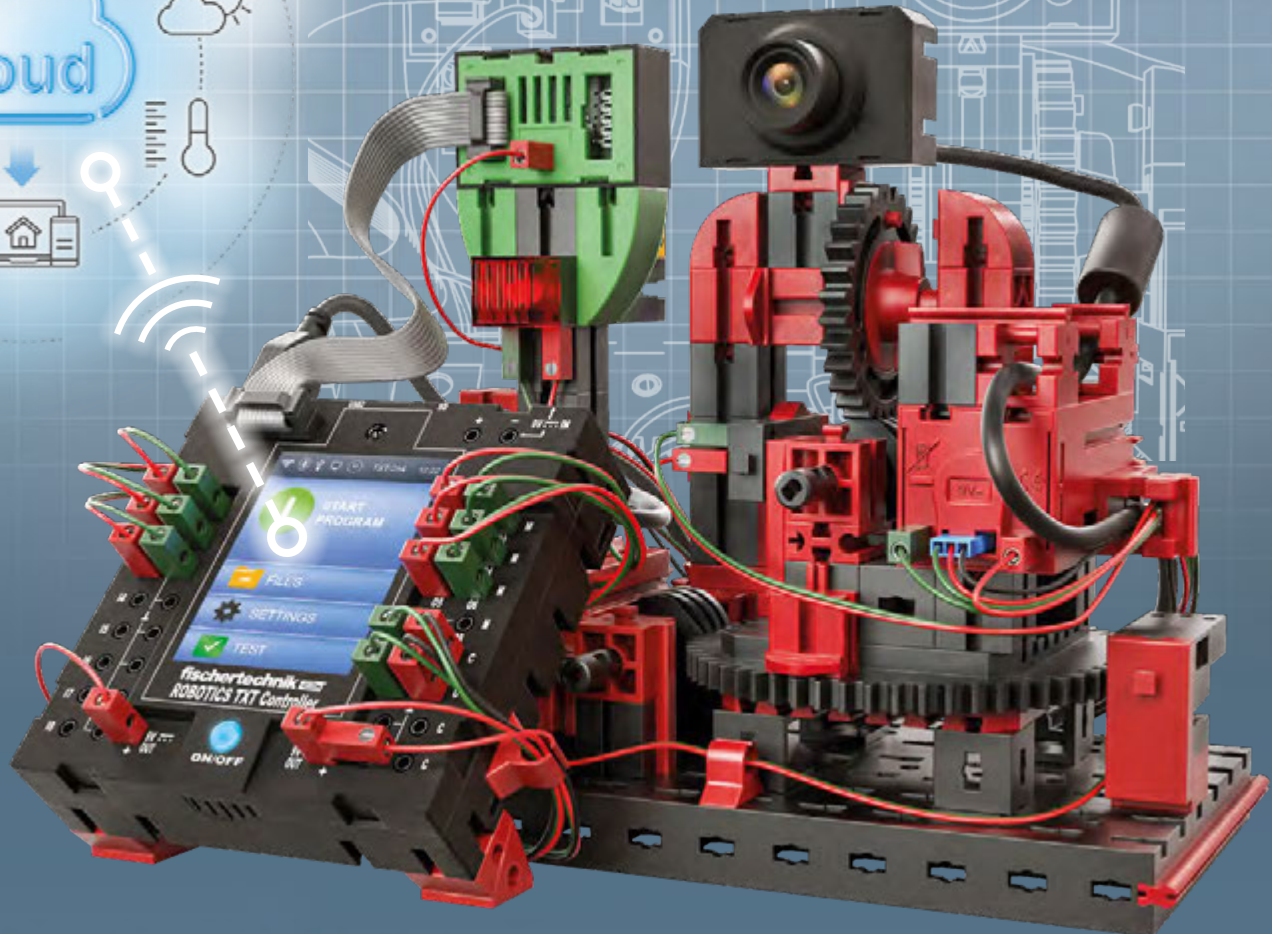

**TXT Smart Home**  
**Robotics Sensor Station IoT**

**6 MODELS**



- **Wichtig! Bitte beachten! Zwingend erforderlich!**  
Zur Steuerung der Modelle dieses Baukastens wird die **Software ROBOPRO 4.4.1** oder höher benötigt.

Die Anleitung zum Download des kostenlosen ROBOPRO-Updates, didaktisches Begleitmaterial zur Programmierung der Modelle mit ROBOPRO sowie eine Anleitung zur Steuerung des Modells Sensorstation über die fischertechnik Cloud sind auf dem fischertechnik eLearning Portal zu finden:

[www.fischertechnik.de/elearning/smart-home](http://www.fischertechnik.de/elearning/smart-home)  
[www.fischertechnik.de/elearning/sensor-station](http://www.fischertechnik.de/elearning/sensor-station)

- **Important! Please observe! Mandatory!**  
The **ROBOPRO 4.4.1 software** or higher is required to control the models of this building kit.

The instructions for downloading this free ROBOPRO update, instruction materials for programming the models with ROBOPRO as well as instructions for controlling the Sensor Station model using the fischertechnik cloud can be found on the fischertechnik eLearning portal:

[www.fischertechnik.de/elearning/smart-home](http://www.fischertechnik.de/elearning/smart-home)  
[www.fischertechnik.de/elearning/sensor-station](http://www.fischertechnik.de/elearning/sensor-station)

- **Important ! À respecter ! Impératif !**  
Pour contrôler les modèles de ce module, le **logiciel ROBOPRO 4.4.1** ou version supérieure est nécessaire.

Vous trouverez les consignes pour télécharger les mises à jour ROBOPRO gratuites, ainsi que la documentation concernant la programmation des modèles avec ROBOPRO et des consignes pour contrôler la station de détection du modèle via le cloud fischertechnik sur le portail d'eLearning fischertechnik:

[www.fischertechnik.de/elearning/smart-home](http://www.fischertechnik.de/elearning/smart-home)  
[www.fischertechnik.de/elearning/sensor-station](http://www.fischertechnik.de/elearning/sensor-station)

- **Belangrijk! A.u.b. opvolgen! Absoluut noodzakelijk!**  
Voor de besturing van de modellen uit deze bouwdoos is de **software ROBOPRO 4.4.1** of hoger vereist.

De gebruiksaanwijzing voor het downloaden van gratis ROBOPRO-updates, didactisch begeleidend materiaal voor de programmering van de modellen met ROBOPRO, evenals een gebruiksaanwijzing voor de besturing van het model Sensorstation, vindt u in het eLearning-portaal in de fischertechnik-cloud van fischertechnik:

[www.fischertechnik.de/elearning/smart-home](http://www.fischertechnik.de/elearning/smart-home)  
[www.fischertechnik.de/elearning/sensor-station](http://www.fischertechnik.de/elearning/sensor-station)

**■ ¡Importante! ¡A tener en cuenta! ¡Absolutamente necesario!**

Para el control de los modelos de este módulo es necesario el **Software ROBOPRO 4.4.1** o superior.

En el portal de eLearning de fischertechnik encontrará las instrucciones para la descarga de la actualización gratuita de ROBOPRO, material didáctico para programar los modelos con ROBOPRO, así como unas instrucciones para el control del modelo de la estación sensora a través de la nube de fischertechnik:

[www.fischertechnik.de/elearning/smart-home](http://www.fischertechnik.de/elearning/smart-home)

[www.fischertechnik.de/elearning/sensor-station](http://www.fischertechnik.de/elearning/sensor-station)

**■ Importante! Observar, por favor! Obrigatoriamente necessário!**

Para controle do modelo desse kit de construção, é necessário o **Software ROBOPRO 4.4.1** ou superior.

A instrução para download da atualização gratuita do ROBOPRO, material de acompanhamento didático para a programação dos modelos com ROBOPRO, assim como uma instrução para o controle da estação sensora do modelo através da "cloud" da fischertechnik, se encontra no portal eLearning da fischertechnik:

[www.fischertechnik.de/elearning/smart-home](http://www.fischertechnik.de/elearning/smart-home)

[www.fischertechnik.de/elearning/sensor-station](http://www.fischertechnik.de/elearning/sensor-station)

**■ Importante! Attenzione! Assolutamente necessario!**

Per il comando dei modelli di questa scatola di costruzioni è necessario il **software ROBOPRO 4.4.1** o superiore.

Le istruzioni per scaricare gli aggiornamenti gratuiti ROBOPRO, il materiale didattico accompagnatorio per la programmazione dei modelli con ROBOPRO e una guida per il comando del modello della stazione di sensori tramite la nuvola informatica fischertechnik sono reperibili sul portale di apprendimento online fischertechnik:

[www.fischertechnik.de/elearning/smart-home](http://www.fischertechnik.de/elearning/smart-home)

[www.fischertechnik.de/elearning/sensor-station](http://www.fischertechnik.de/elearning/sensor-station)

**■ Важно! Обратите внимание! Необходимый элемент!**

Для управления моделями, собранными из этого конструктора, необходима программа ROBOPRO 4.4.1 или более поздней версии.

Инструкцию по установке программы, руководство по программированию моделей с ROBOPRO и управлению сенсорной станцией через удаленную вычислительную среду fischertechnik вы найдете на портале fischertechnik eLearning:

[www.fischertechnik.de/elearning/smart-home](http://www.fischertechnik.de/elearning/smart-home)

[www.fischertechnik.de/elearning/sensor-station](http://www.fischertechnik.de/elearning/sensor-station)

**■ 重要！请注意！强制要求！**

要使用组件模型，需要使用软件ROBOPRO 4.4.1或更高版本。

在fischertechnik网上学习（eLearning）门户可以查看下载免费升级版ROBOPRO的说明书，ROBOPRO模型的编程教材和通过fischertechnik云控制传感器工作站模型的说明书。

网站信息：

[www.fischertechnik.de/elearning/smart-home](http://www.fischertechnik.de/elearning/smart-home)

[www.fischertechnik.de/elearning/sensor-station](http://www.fischertechnik.de/elearning/sensor-station)

**Inhalt**  
**Contents**  
**Contenu**

**Inhoud**  
**Contenido**  
**Conteúdo**

**Contenuto**  
**Содержание**  
**目录**

Einzelteilübersicht / Spare parts list / Liste des pièces détachées / Onderdelenoverzicht / Lista da piezas / Resumo de peça individual /  
Singoli componenti / Перечень деталей / 零件概览 ..... 3

Montagetips / Tips for assembly / Tuyaux pour le montage / Montagetips / Consejos para el montaje / "Dicas" para montagem /  
Consigli per il montaggio / Советы по сборке / 装配建议 ..... 4



Beleuchtung / Lighting / Éclairage/ Verlichting /  
Iluminación / Iluminação / Illuminazione /  
Освещение / 照明 .....6



Lärmsensor / Noise sensor / Capteur de bruit /  
Lawaaisensor / Sensor de ruido / Sensor de ruído /  
Sensore di rumore / Датчик шума /  
噪音传感器 .....8



Wohlfühlsensor / Wellness sensor / Capteur de bien-être /  
Sfeersensor / Sensor de bienestar / Sensor de conforto /  
Sensore di benessere / Датчик комфорта /  
感觉传感器 ..... 10



Stationäre Kamera / Stationary camera / Cámara fixe /  
Stationaire camera / Cámara fija / Cámara estacionária /  
Videocamera stazionaria / Стационарная  
камер / 固定相机 ..... 12



Barometer / Barometer / Baromètre / Barometer /  
Barómetro / Barômetro / Barometri / Барометр /  
晴雨表 ..... 14

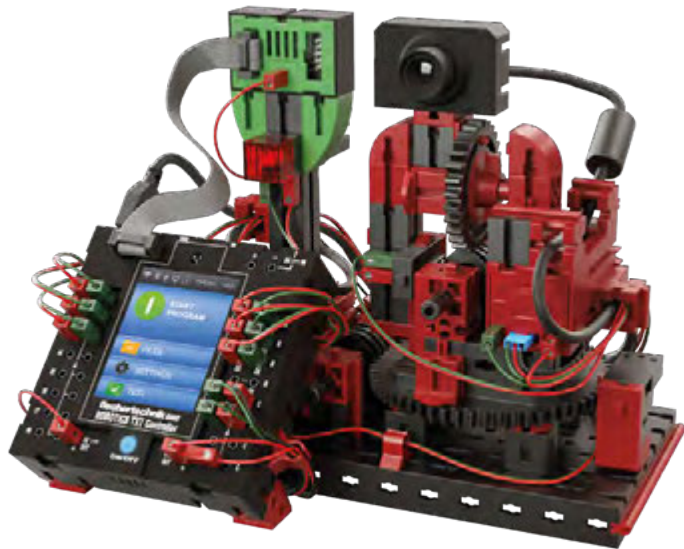

Sensorstation/ Sensor Station / Station de détection / Sensorstation /  
Estación sensora / Estação sensora / Stazione di sensori /  
Сенсорная станция / 传感器工作站 ..... 18

**Einzelteilübersicht**  
**Spare parts list**  
**Liste des pièces détachées**

**Onderdelenoverzicht**  
**Lista da piezas**  
**Resumo de peça individual**

**Singoli componenti**  
**Перечень деталей**  
**零件概览**

	10497 1 x		31330 2 x		32882 2 x		36952 2 x
	117336 1 x		31336 14 x		35031 1 x		37237 8 x
	137125 1 x		31337 18 x		35049 3 x		37468 13 x
	137677 4 x		31360 1 x		35063 4 x		37636 4 x
	152522 1 x		31390 1 x		35072 2 x		37679 1 x
	153422 2 x		31391 1 x		35073 2 x		37783 2 x
	156502 2 x		31602 2 x		35078 1 x		38241 2 x
	162134 3 x		31771 1 x		35079 1 x		38246 4 x
	163201 2 x		31848 6 x		35084 1 x		38251 1 x
	163202 2 x		31981 4 x		35608 1 x		38413 1 x
	167358 1 x		31982 15 x		35969 4 x		38416 1 x
	168961 1 x		32064 7 x		35980 3 x		38428 4 x
	168966 1 x		32330 2 x		36264 1 x		38464 3 x
	31010 4 x		32698 1 x		36323 7 x		38546 2 x
	31058 1 x		32854 3 x		36334 2 x		
	31060 11 x		32879 4 x		36443 1 x		
	31061 5 x		32881 9 x		36950 6 x		

**Montagetipps**  
**Tips for assembly**  
**Tuyaux pour le montage**

**Montagetipps**  
**Consejos para el montaje**  
**"Dicas" para montagem**

**Consigli per il montaggio**  
**Советы по сборке**  
**装配建议**

Kabel und Stecker  
 Plugs and cables  
 Fiches et des câbles

Stekkers en cables  
 Enchufes en cables  
 Cabos e contatos

Cavi e connettori  
 Провода и штекеры  
 电缆和插头

1

2 x 15 cm  
 1 x 25 cm  
 1 x 35 cm  
 2 x 60 cm

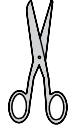

2

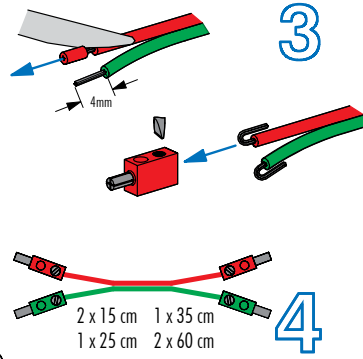

3

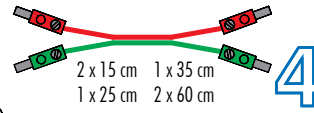

4

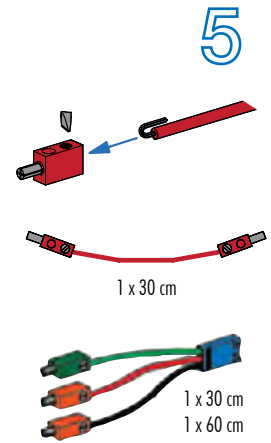

5

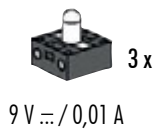
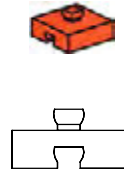
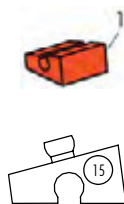
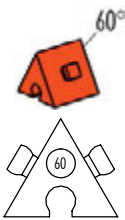
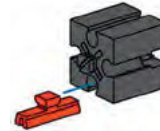

Achtung: Beim Anschluß auf richtige Polung achten.  
 Caution: Make sure the terminals are connected correctly.  
 Attention: lors du raccordement, veiller à ce que la polarisation soit exacte.  
 Pas op: let bij het aansluiten op de juiste polariteit.  
 Atención: al conectar, procurar que los polos estén correctamente colocados.  
 Atenção: Por ocasião da conexão atentar para a polaridade correta.  
 Attenzione: nel collegamento osservare la corretta polarità.  
 Внимание: при подключении соблюдать полярность.  
 注意: 连接时应注意极性正确。

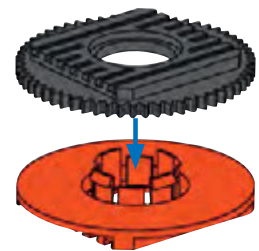

- Alle Einzelteile, insbesondere bewegliche Teile sind falls notwendig zu warten und zu reinigen.
- All components, especially moving parts, should be maintained and cleaned as necessary.
- Toutes les pièces détachées et en particulier les pièces mobiles, sont, si nécessaire, à entretenir et à nettoyer.
- Alle onderdelen, vooral de bewegende delen, kunnen, indien noodzakelijk, onderhouden en gereinigd worden.
- Es necesario limpiar y mantener en buen estado todas las diferentes piezas - especialmente las piezas móviles.

- Caso necessário, todas as peças individuais, especialmente peças móveis, tem que ser submetidas à manutenção e ser limpas.
- Se necessario, tutti i singoli componenti, soprattutto le parti mobili, si devono eventualmente sottoporre a manutenzione e pulizia.
- Все детали, особенно подвижные, требуют ухода и чистки.
- 必要时应保养和清洁所有零件, 尤指运动部件。

## Sicherheitshinweise Safety Information Consignes de sécurité

## Veiligheidsrichtlijnen Indicaciones de seguridad Observações sobre segurança

## Informazioni per la sicurezza Указания по технике безопасности 安全指南

- Die Anschlussklemmen dürfen nicht kurzgeschlossen werden.
  - Drähte nicht in Steckdose einführen!
  - Ladegerät regelmäßig auf Schäden überprüfen. Bei einem Schaden darf das Ladegerät bis zur vollständigen Reparatur nicht mehr verwendet werden.
  - Alle elektrischen Bauteile (Motoren, Lampen, ROBO TX Controller) dürfen ausschließlich an Stromversorgungen von fischertechnik angeschlossen werden.
- Do not short circuit the connecting terminals!
  - Do not insert the wires into an outlet!
  - Regularly inspect battery charger for damage. If the battery charger has been damaged, it should not be used further until fully repaired.
  - No electrical components (motors, lamps, ROBO TX Controller) are to be connected to any other power supply than that provided by fischertechnik.
- Il est interdit de court-circuiter les bornes de raccordement.
  - Contrôlez régulièrement le chargeur en vue d'éventuelles détériorations
  - En cas de détérioration, il est interdit d'utiliser le chargeur jusqu'à ce qu'il ait été intégralement réparé
  - Tous les composants électriques (moteurs, lampes, ROBO TX Controller) ne doivent être branchés aux alimentations électriques uniquement que par la société Fischertechnik.
- De aansluitklemmen mogen niet worden kortgesloten.
  - Geen draden in de contactdoos steken!
  - Laadtoestel regelmatig controleren op schade. Bij schade mag het laadtoestel niet meer gebruikt worden tot het volledig hersteld is.
  - Alle elektrische componenten (motoren, lampen, ROBO TX Controller) mogen uitsluitend op stroomvoorzieningen van fischertechnik worden aangesloten.
- Los bornes de conexión no pueden ser puestas en cortocircuito.
  - No introducir hilos en la toma de corriente!
  - Comprobar con regularidad si el cargador presenta daños. En caso de presentar daños, el cargador no debe volver a ser utilizado hasta que esté completamente reparado.
  - Todos los componentes eléctricos (motores, luces, ROBO TX Controller) deben conectarse a la alimentación de corriente de la técnica Fischer exclusivamente.
- Os terminais de conexão não devem ser curto-circuitados.
  - Nunca introduzir fios na tomada!
  - Verificar regularmente se o carregador apresenta danos. Em caso de dano, o carregador não deverá ser utilizado enquanto não estiver plenamente consertado.
  - Todas as peças componentes elétricas (motores, lâmpadas, ROBO TX Controller) só podem ser exclusivamente conectadas em abastecimentos de corrente da Fischertechnik.
- I morsetti di allacciamento non devono essere cortocircuitati.
  - Non inserire i fili nella presa elettrica.
  - Controllare periodicamente se il caricabatterie presenta dei danni. In caso di danni, il caricabatterie non deve più essere utilizzato fino alla riparazione.
  - Tutti i componenti elettrici (motori, lampadine, ROBO TX Controller) devono essere collegati esclusivamente ad alimentatori fischertechnik.
- Не замыкайте накоротко соединительные клеммы.
  - Не вставляйте в розетку провода!
  - Регулярно проверяйте зарядное устройство на отсутствие повреждений. При наличии повреждений использовать зарядное устройство до выполнения его полного ремонта не разрешается.
  - Все электрические детали (электромоторы, лампочки.) можно подключать только к источникам электропитания от fischertechnik.
- 接线柱不允许被短路。
  - 禁止将金属丝插入插座！
  - 经常检查充电器是否有损坏情况。如果充电器有损，直到完全修好为止不可以再使用。
  - 只允许将所有电气部件（传感器，电机）与慧鱼技术产品的电源装置相连接

- Die Modelle dürfen nur an Geräte der Schutzklasse II angeschlossen werden, die mit dem entsprechenden Symbol gekennzeichnet sind.
- Ensure that the models are connected only to equipment rated in protection category II and marked with the appropriate symbol.
- Le raccordement des maquettes est uniquement permis à des appareils dotés de la catégorie de protection II qui portent le pictogramme respectif.
- De modellen mogen alleen op apparaten uit beschermingsklasse II worden aangesloten, die zijn voorzien van het bijbehorende symbol.
- Los modelos sólo pueden ser conectados a aparatos de clase de protección II que están identificados con el símbolo correspondiente.
- Os modelos somente devem ser conectados nos aparelhos da classe de proteção II, que são identificados com o símbolo correspondente.
- I modelli devono essere collegati solo ad apparecchi della classe di protezione II, contrassegnati con il relativo simbolo.
- Модели можно подключать только к приборам класса защиты II, обозначенным соответствующим знаком.
- 这些模型只允许连接到具有防护等级 II 的装置上，这类装置被用相应的符号进行了标识。

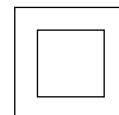

- Das Spielzeug darf nur mit einer der folgenden fischertechnik Energiequellen benutzt werden: Power Set oder Art.-Nr.: 35537 Accu Pack 8,4V.
- The toy may only be used with one of the following fischertechnik energy sources: Power Set or Art No.: 35537 Accu Pack 8.4V.
- L'utilisation de ce jouet n'est permis qu'avec l'une des sources d'énergie fischertechnik suivantes: Power Set ou Art. n° : 35537 pack d'accumulateurs 8,4 volts.
- Het speelgoed mag uitsluitend met een van de volgende fischertechnik energiebronnen worden gebruikt: art.nr.: Power Set of art.nr.: 35537 accupack 8,4V
- El juguete se debe utilizar únicamente con una de las siguientes fuentes de energía: Power Set o Art. No. 35537 paquete acumulador de 8,4V.
- O brinquedo somente pode ser utilizado com uma das seguintes fontes de energia da fischertechnik: Power Set ou art. n°: 35537 Bloco de bateria de 8,4V.
- Questo giocattolo può essere utilizzato solo con le seguenti fonti di energia fischertechnik: Power Set oppure cod. prod.: 35537 confezione batterie da 8,4V.
- Игрушку можно использовать только с одним из следующих источников энергии от fischertechnik: Power Set или арт. №: 35537 Accu Pack 8,4B
- 该玩具只允许使用如下的慧鱼 (fischertechnik) 能量源：Power Set，或者商品号：35537，8.4V 电池套件 (Accu Pack)

- Achtung! Verletzungsgefahr an Bauteilen mit funktionsbedingten scharfen Kanten und Spitzen!
- Caution! Be careful not to hurt yourself on components with sharp or pointed edges!
- Attention! Risque de blessure sur les éléments comportant des arêtes et o pointes vives indispensables au bon fonctionnement!
- Let op! U kunt zich bezeren aan bouwstenen met scherpe randen of punten!
- Attenzione! Esiste il pericolo di lesione con i pezzi di costruzione che hanno bordi e punte spigolosi necessari per la funzionalità del pezzo!
- Atenção! Perigo de ferimentos em peças componentes com cantos vivos e pontas obrigatórias para o funcionamento!
- Attenzione! Pericolo di lesioni dovute a componenti con spigoli vivi e punte per motivi funzionali!
- Будьте осторожны! Об острые края деталей и и наконечники можно порезаться!
- 注意！因功能需要而带有锋利的棱边和尖角的部件可能会带来受伤危险！

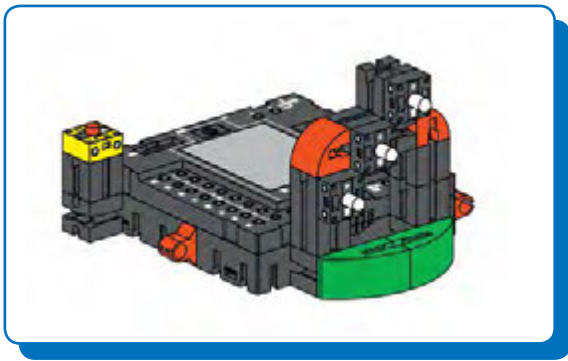

**Beleuchtung  
Lighting  
Éclairage**

**Verlichting  
Iluminación  
Iluminação**

**Illuminazione  
Освещение  
照明**

- TXT Controller (Art.-Nr. 522429) nicht im Baukasten enthalten
- TXT Controller (Art.-Nr. 522429) not included in the modular kit
- TXT Controller (Art.-Nr. 522429) n'est pas contenue dans le kit
- TXT Controller (Art.-Nr. 522429) niet in de bouwdoos opgenomen
- TXT Controller (Art.-Nr. 522429) no está incluido en el conjunto
- TXT Controller (Art.-Nr. 522429) não contido no sistema de construção por blocos
- TXT Controller (Art.-Nr. 522429) non incluso nella scatola di montaggio
- TXT Controller (Art.-Nr. 522429) не входит в комплект конструктора
- TXT Controller (Art.-Nr. 522429) 不包含在组件

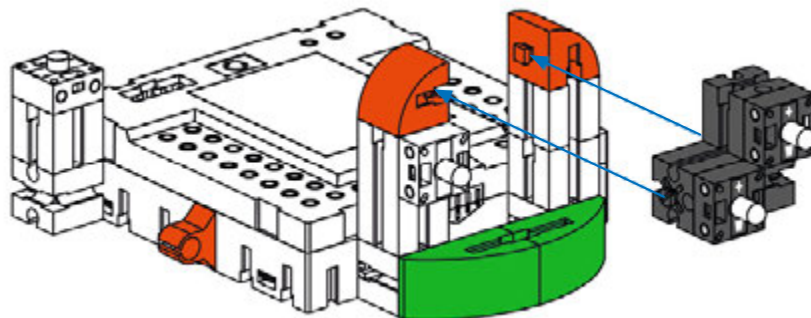
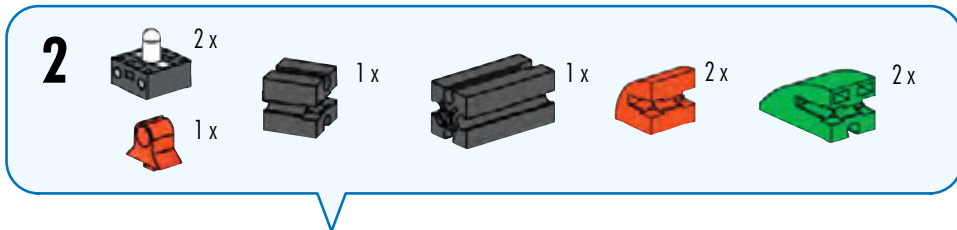
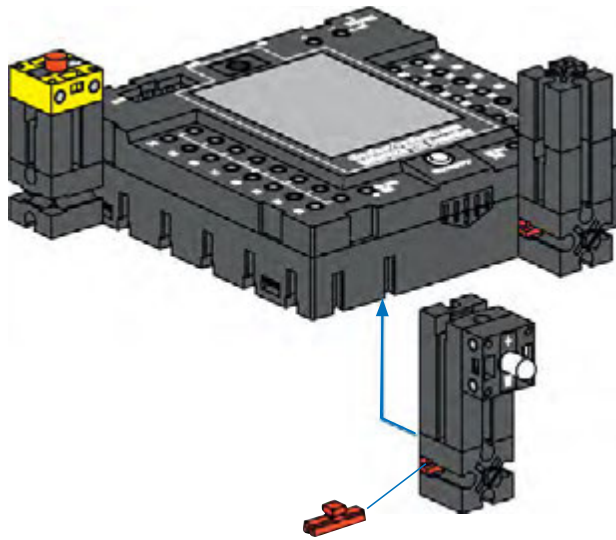
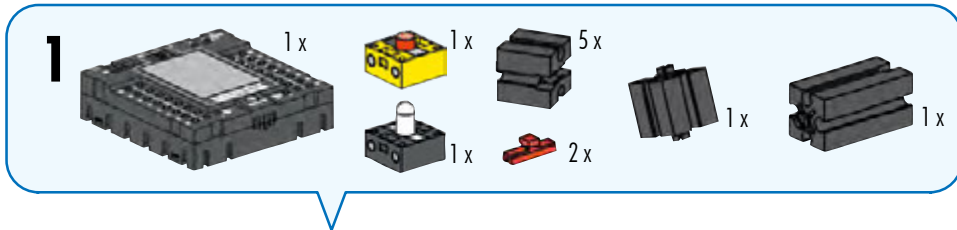



**3**  3 x

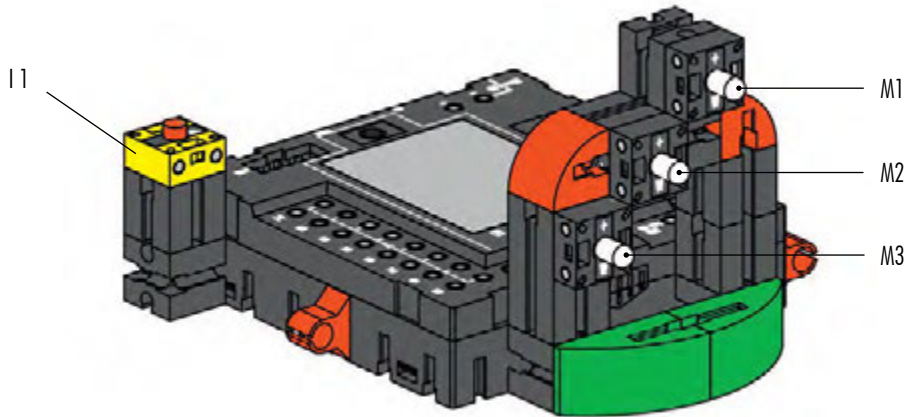
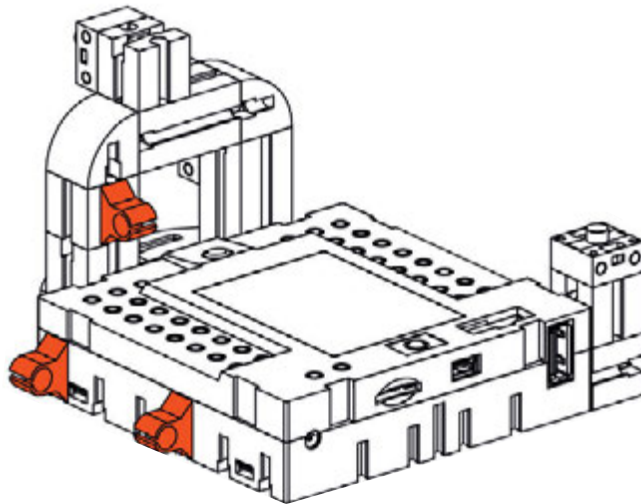

Schaltplan  
Circuit diagram  
Plan électrique

Schakelschema  
Diagrama de circuitos  
Plano elétrico de ligação

Schema elettrico  
Схема подключения  
电路图

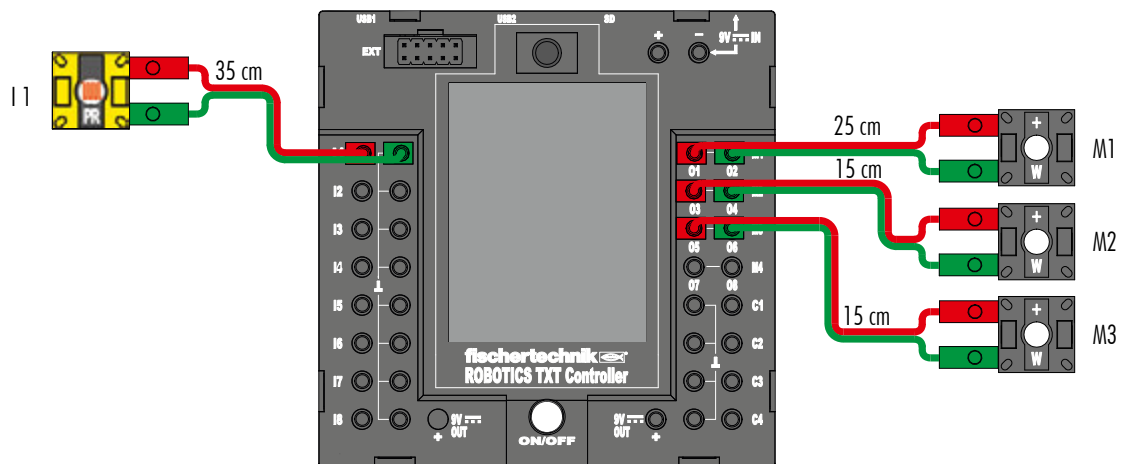

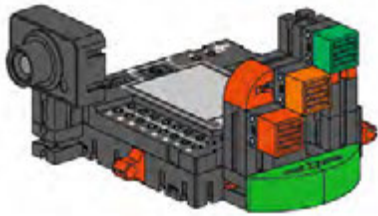

**Lärmsensor**  
**Noise sensor**  
**Capteur de bruit**

**Lawaaisensor**  
**Sensor de ruído**  
**Sensor de ruído**

**Sensore di rumore**  
**Датчик шума**  
**噪音传感器**

- TXT Controller (Art.-Nr. 522429) nicht im Baukasten enthalten
- TXT Controller (Art.-Nr. 522429) not included in the modular kit
- TXT Controller (Art.-Nr. 522429) n'est pas contenue dans le kit
- TXT Controller (Art.-Nr. 522429) niet in de bouwdoos opgenomen
- TXT Controller (Art.-Nr. 522429) no está incluido en el conjunto
- TXT Controller (Art.-Nr. 522429) não contido no sistema de construção por blocos
- TXT Controller (Art.-Nr. 522429) non incluso nella scatola di montaggio
- TXT Controller (Art.-Nr. 522429) не входит в комплект конструктора
- TXT Controller (Art.-Nr. 522429) 不包含在组件

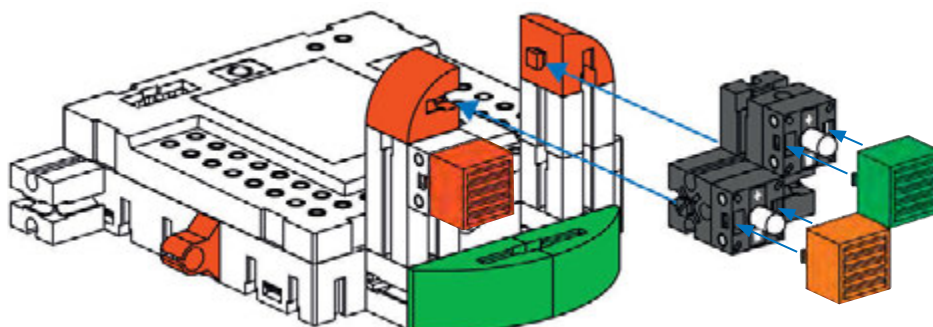
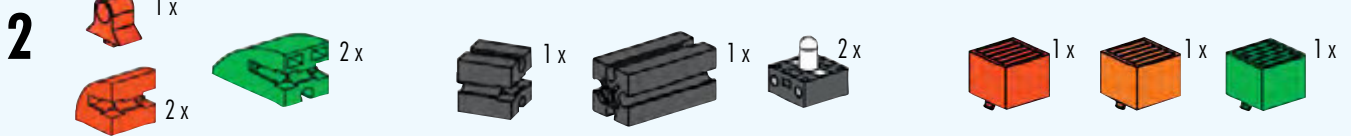
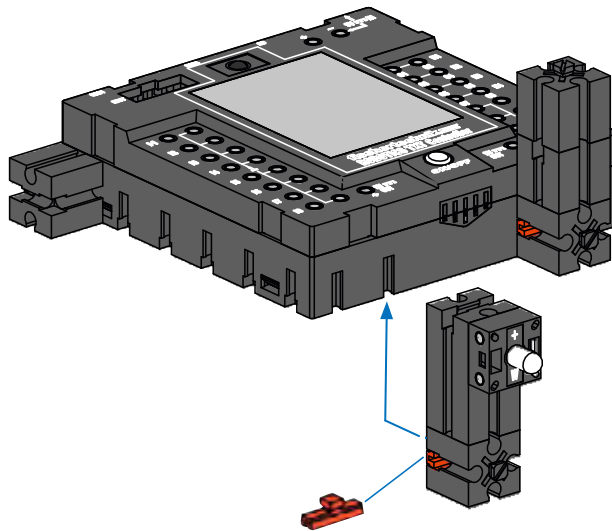
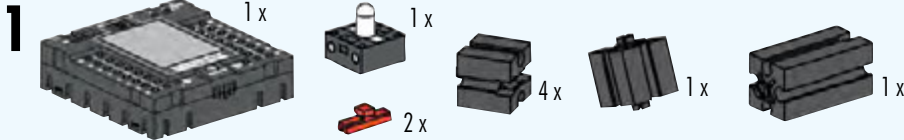

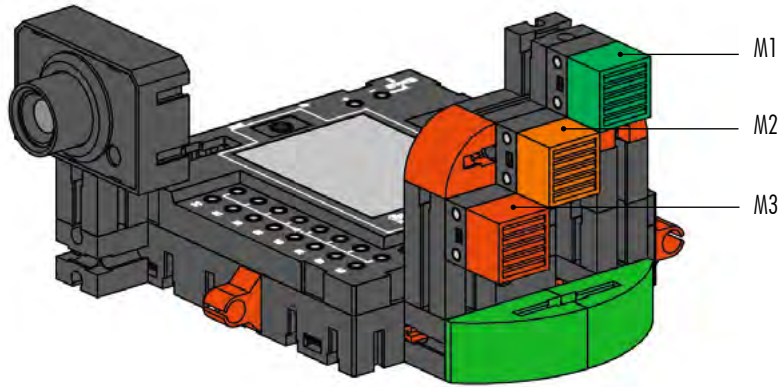
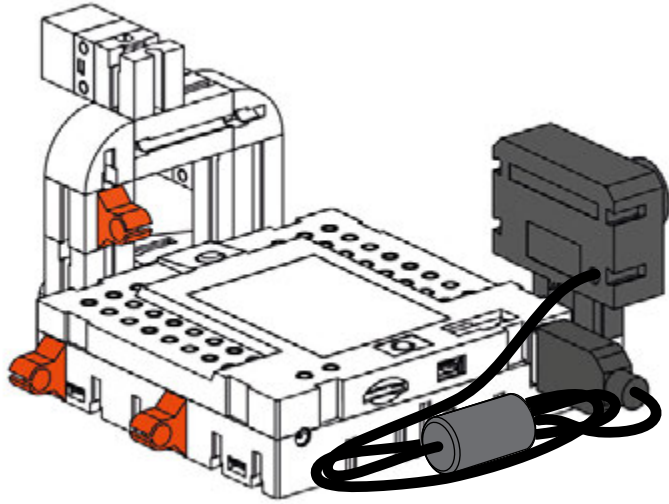
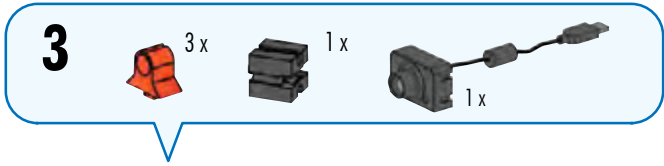

Schaltplan  
Circuit diagram  
Plan électrique

Schakelschema  
Diagrama de circuitos  
Plano elétrico de ligação

Schema elettrico  
Схема подключения  
电路图

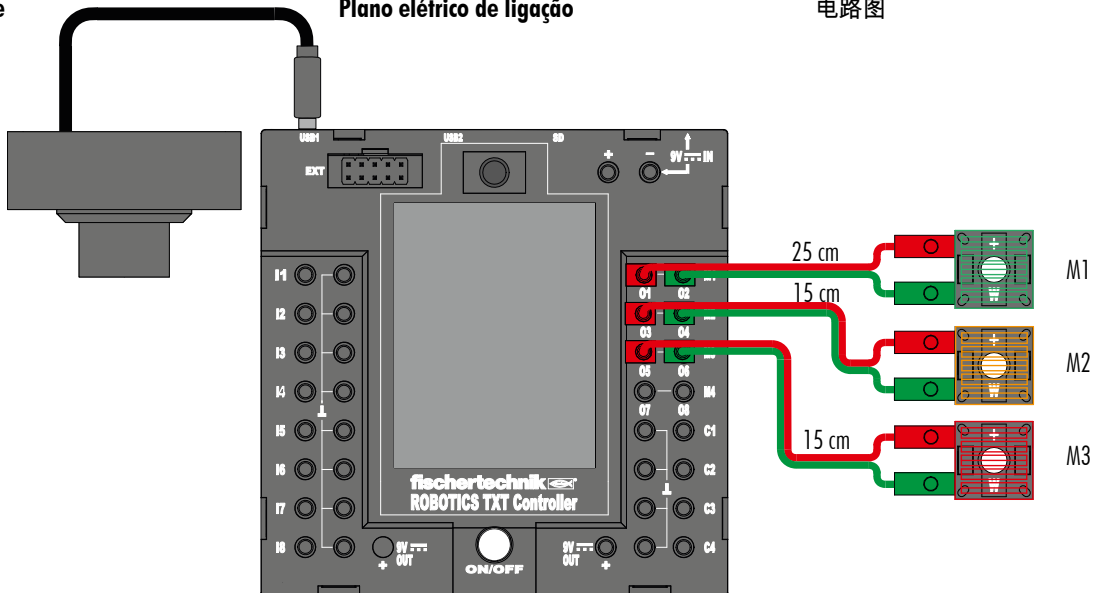



**Wohlfühlsensor**

**Wellness sensor**

**Capteur de bien-être**

**Sfeersensor**

**Sensor de bienestar**

**Sensor de conforto**

**Sensore di benessere**

**Датчик комфорта**

**感觉传感器**

- TXT Controller (Art.-Nr. 522429) nicht im Baukasten enthalten
- TXT Controller (Art.-Nr. 522429) not included in the modular kit
- TXT Controller (Art.-Nr. 522429) n'est pas contenue dans le kit
- TXT Controller (Art.-Nr. 522429) niet in de bouwdoos opgenomen
- TXT Controller (Art.-Nr. 522429) no está incluido en el conjunto
- TXT Controller (Art.-Nr. 522429) não contido no sistema de construção por blocos
- TXT Controller (Art.-Nr. 522429) non incluso nella scatola di montaggio
- TXT Controller (Art.-Nr. 522429) не входит в комплект конструктора
- TXT Controller (Art.-Nr. 522429) 不包含在组件

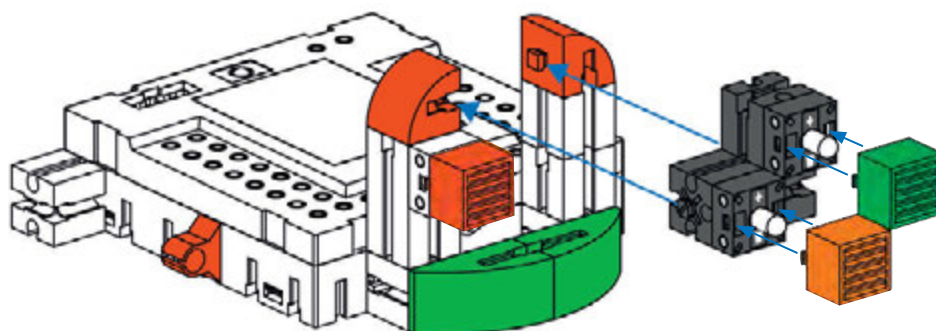
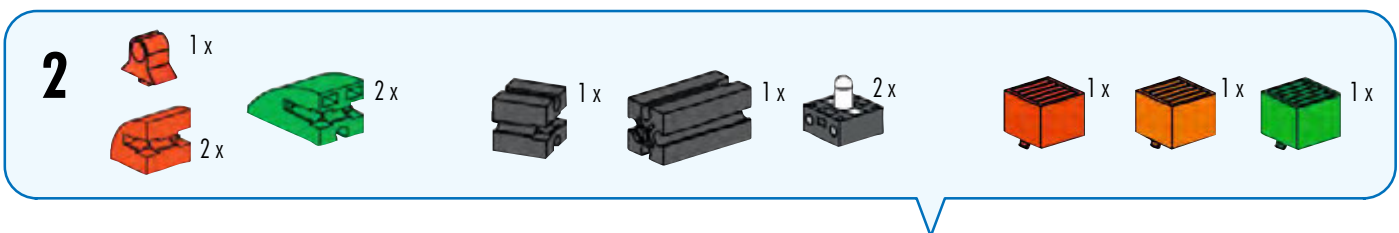
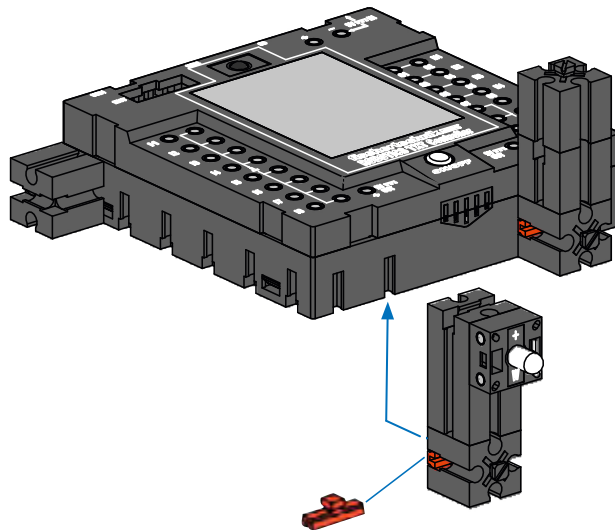
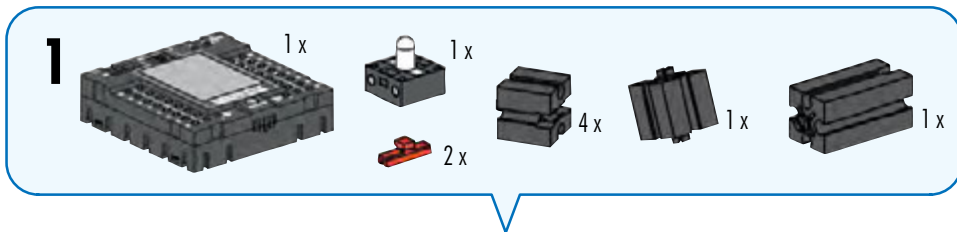

3

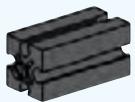
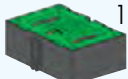
- 3x 
- 2x 
- 1x 

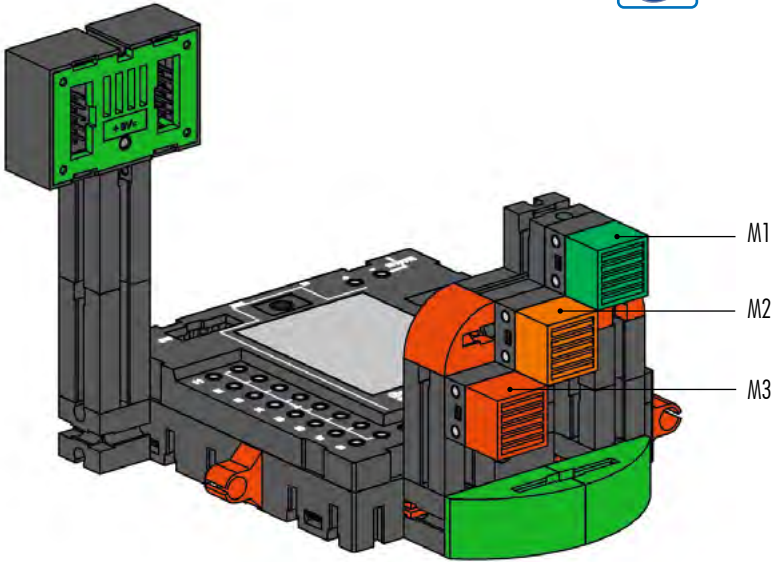
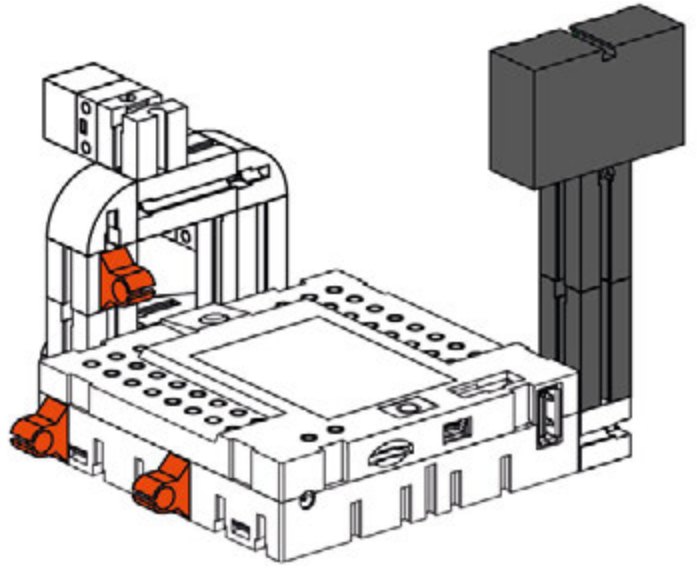

M1

M2

M3

Schaltplan  
Circuit diagram  
Plan électrique

Schakelschema  
Diagrama de circuitos  
Plano elétrico de ligação

Schema elettrico  
Схема подключения  
电路图

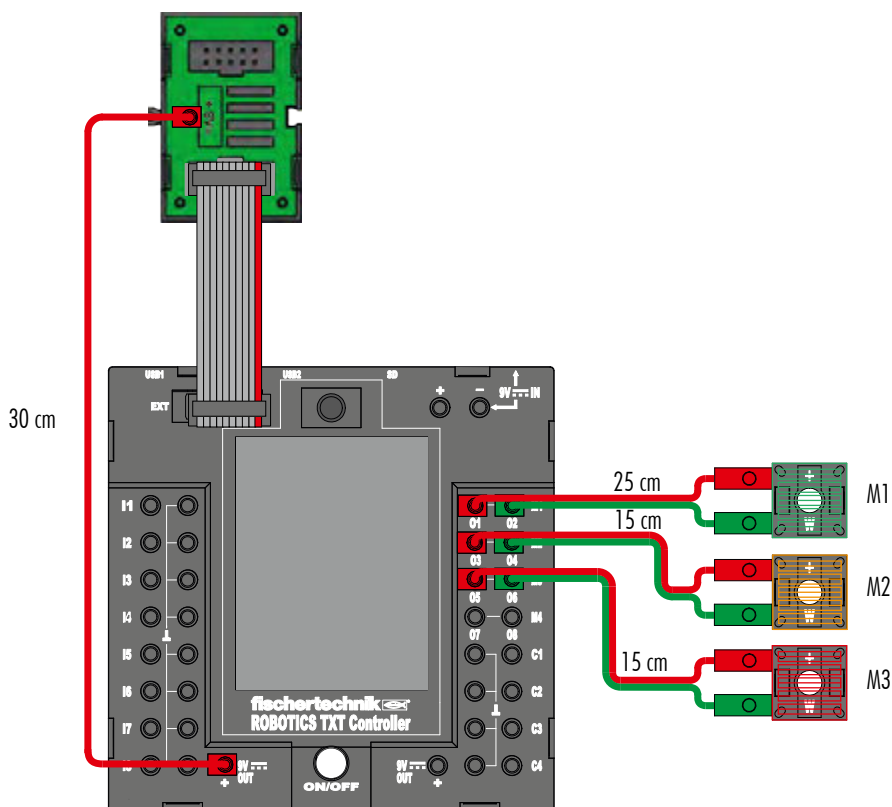

**Stationäre Kamera**  
**Stationary camera**  
**Caméra fixe**

**Stationaire camera**  
**Cámara fija**  
**Câmera estacionária**

**Videocamera stazionaria**  
**Стационарная камер**  
**固定相机**

- TXT Controller (Art.-Nr. 522429) nicht im Baukasten enthalten
- TXT Controller (Art.-Nr. 522429) not included in the modular kit
- TXT Controller (Art.-Nr. 522429) n'est pas contenue dans le kit
- TXT Controller (Art.-Nr. 522429) niet in de bouwdoos opgenomen
- TXT Controller (Art.-Nr. 522429) no está incluido en el conjunto
- TXT Controller (Art.-Nr. 522429) não contido no sistema de construção por blocos
- TXT Controller (Art.-Nr. 522429) non incluso nella scatola di montaggio
- TXT Controller (Art.-Nr. 522429) не входит в комплект конструктора
- TXT Controller (Art.-Nr. 522429) 不包含在组件

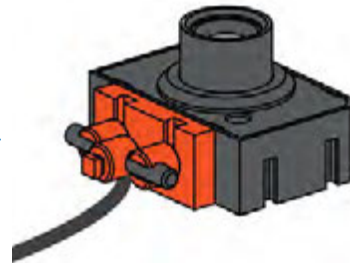
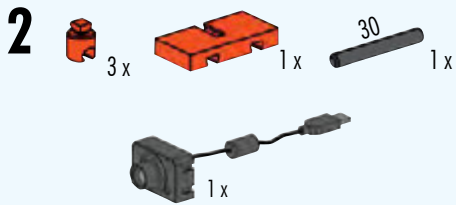
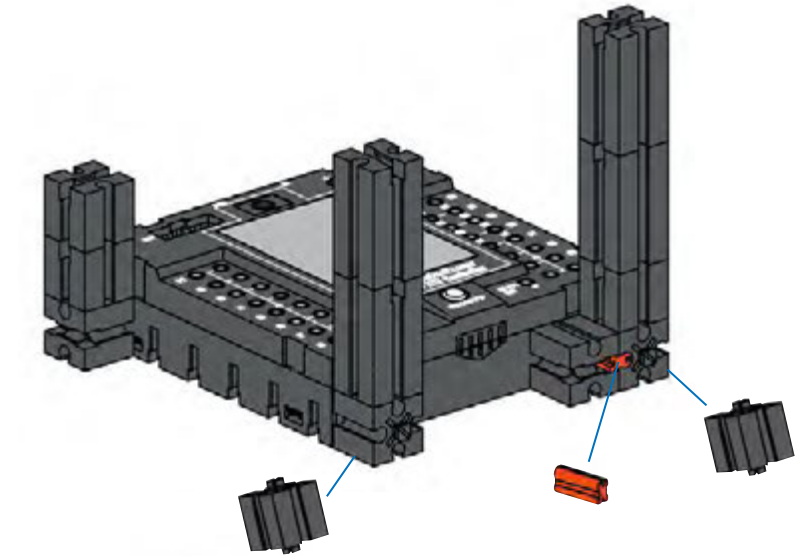
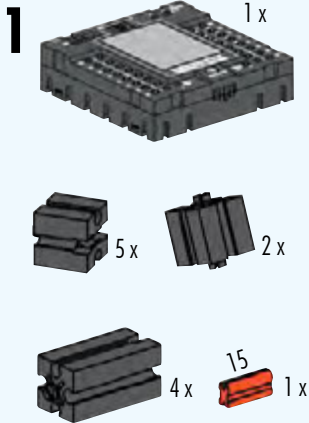

30 mm

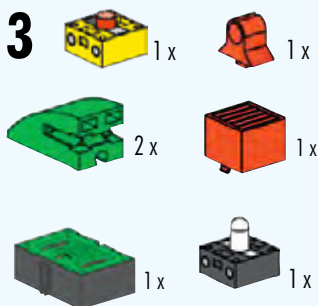
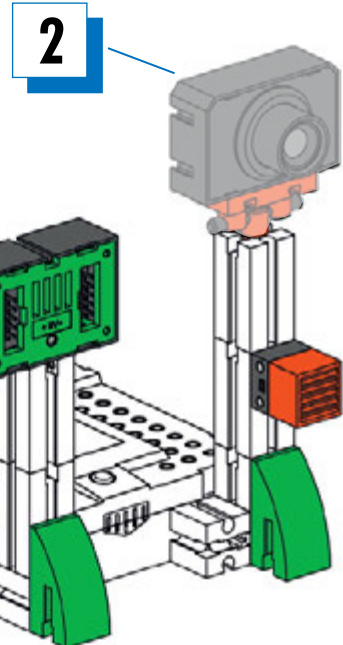

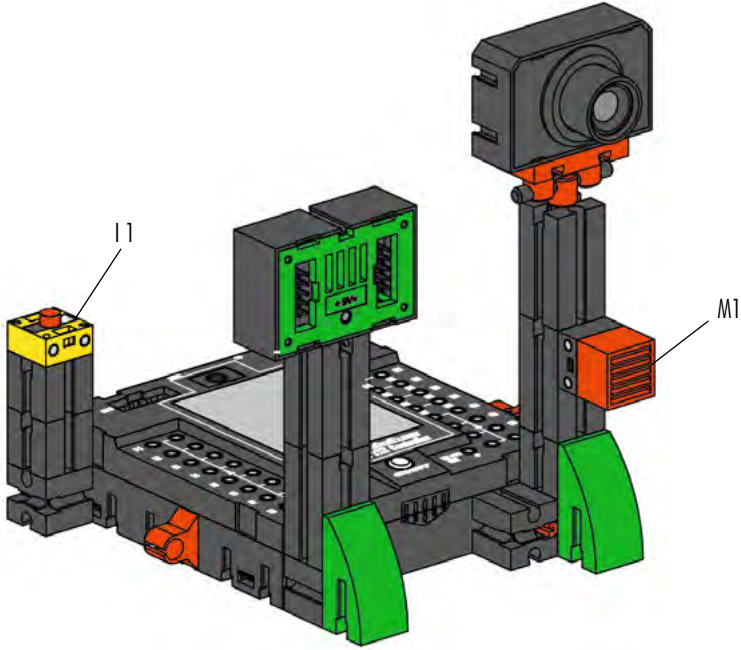
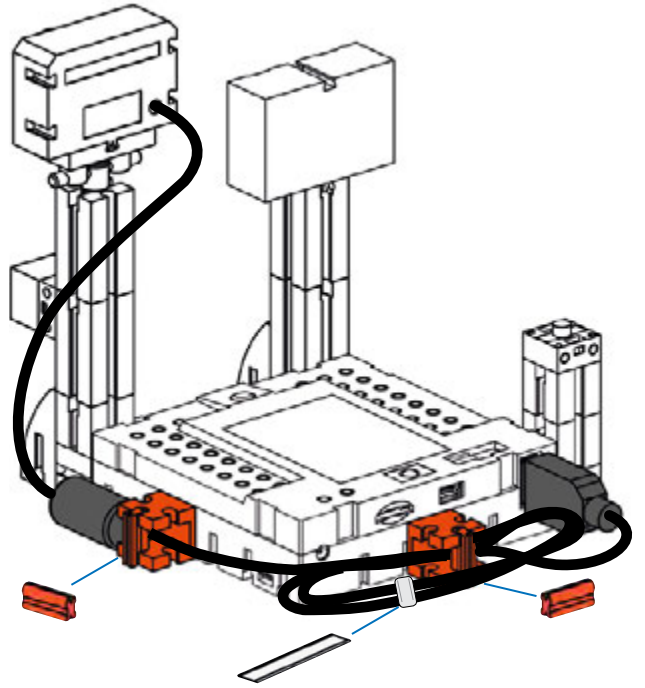
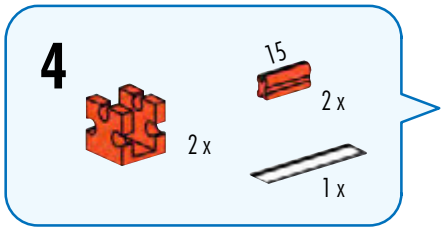

**Schaltplan**  
Circuit diagram  
Plan électrique

**Schakelschema**  
Diagrama de circuitos  
Plano elétrico de ligação

**Schema elettrico**  
Схема подключения  
电路图

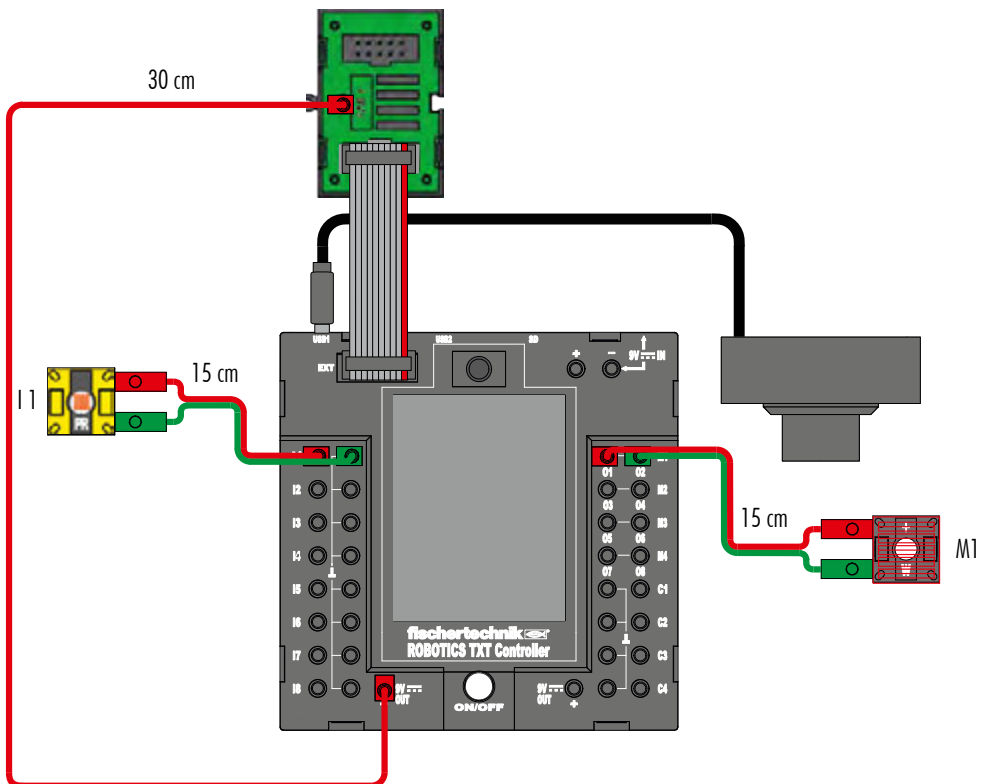

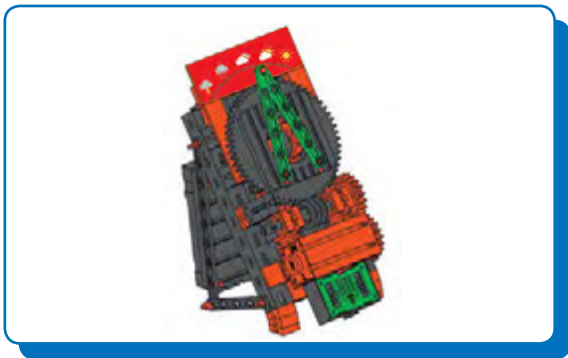

Barometer  
Barometer  
Baromètre

Barometer  
Barómetro  
Barômetro

Barometri  
Барометр  
晴雨表

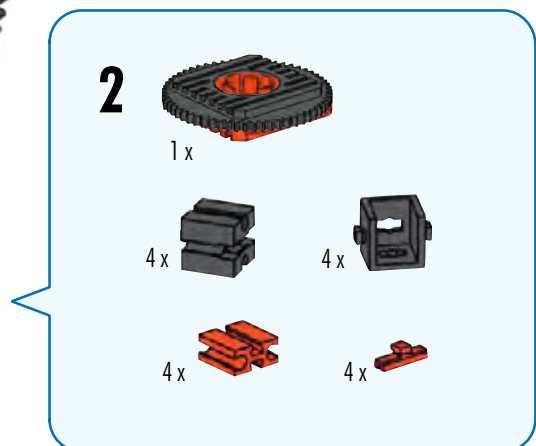
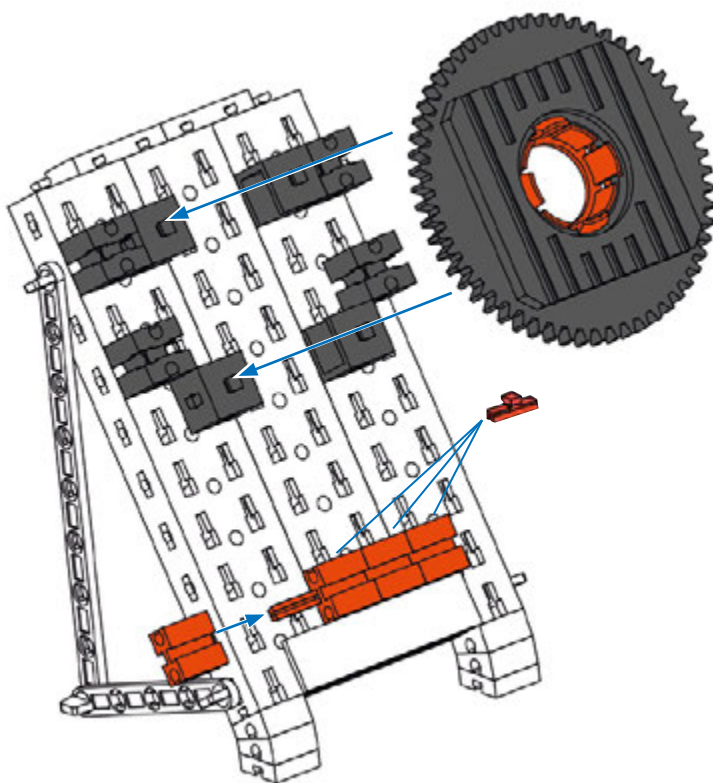
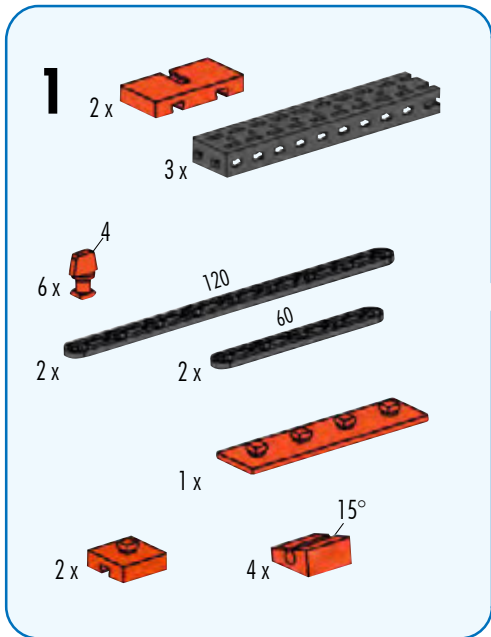



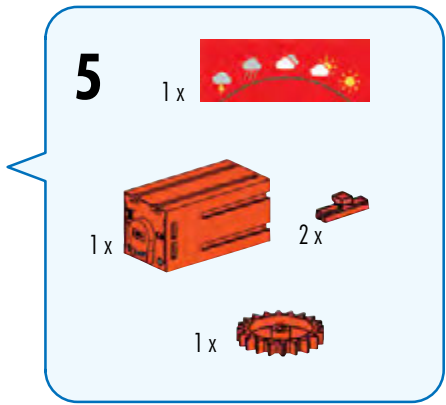
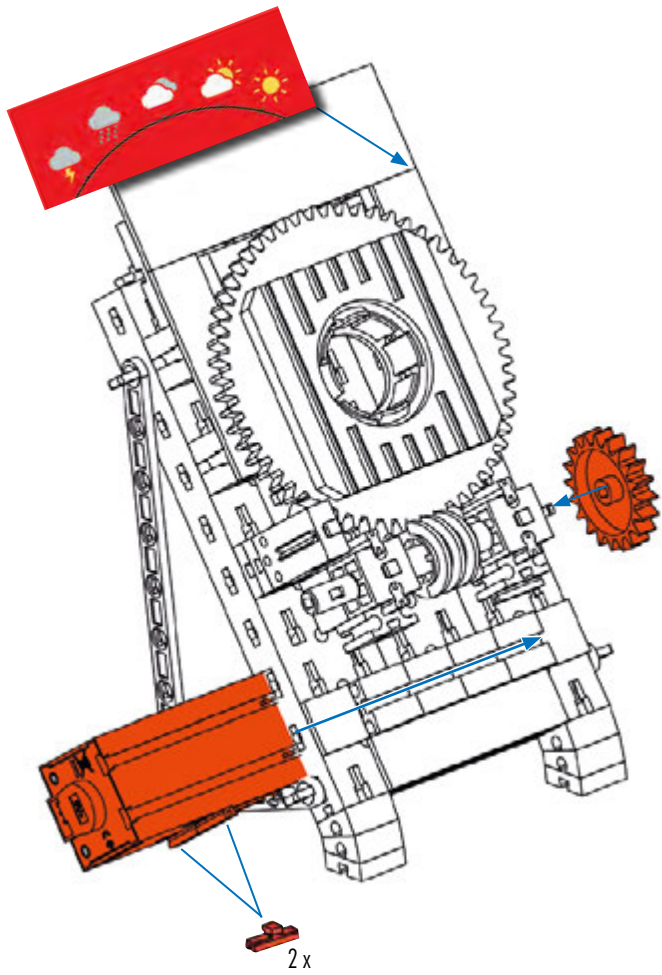
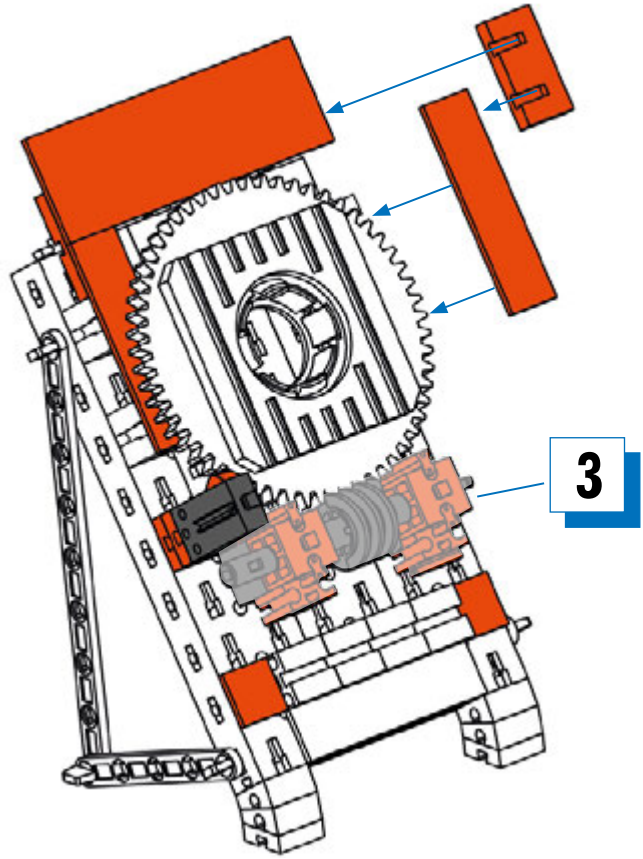
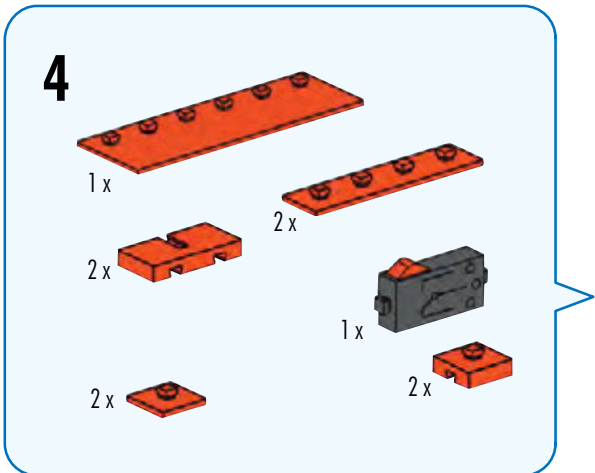
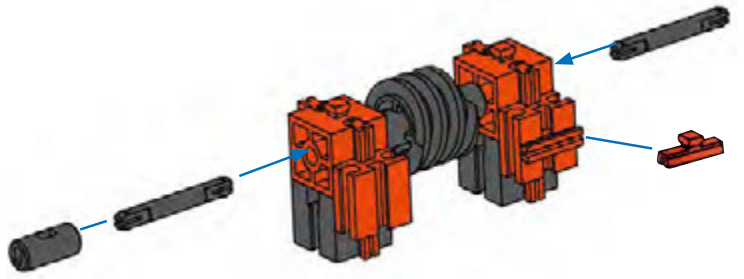
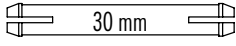
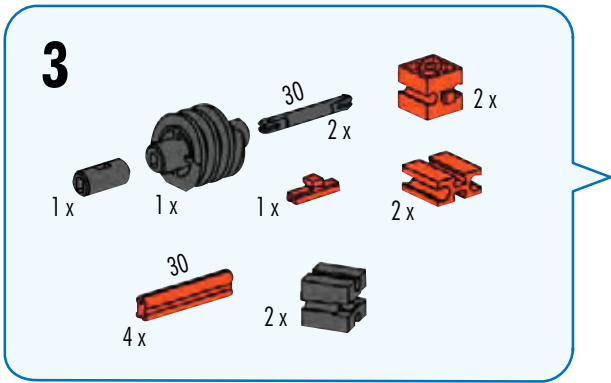

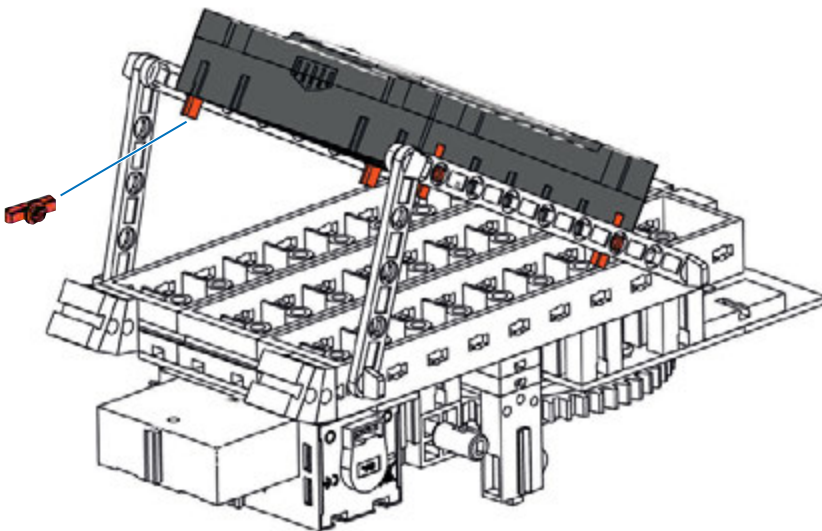
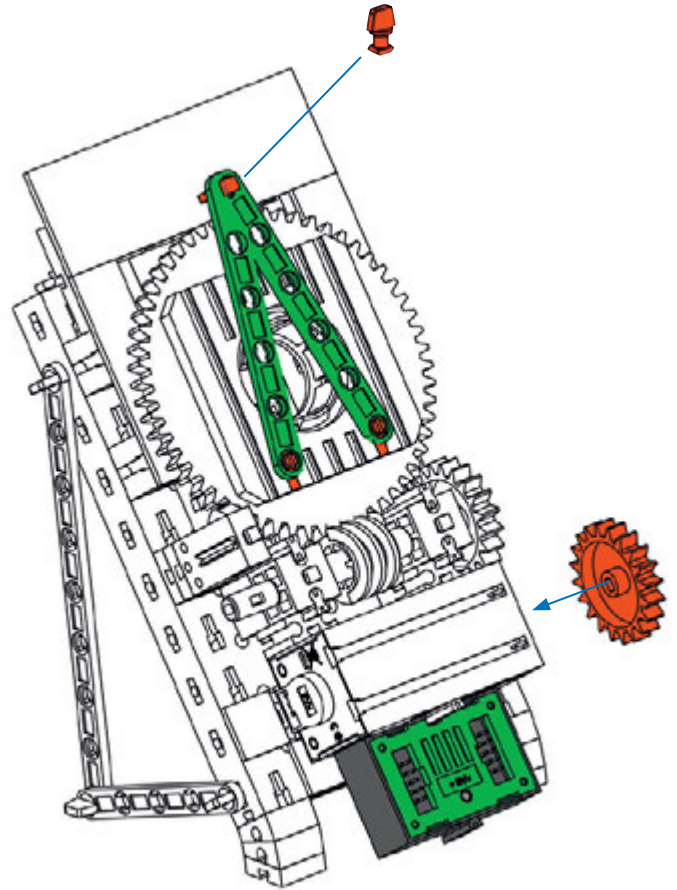
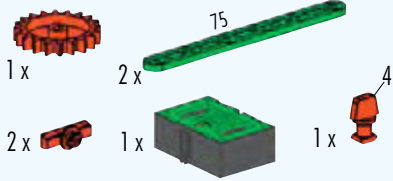
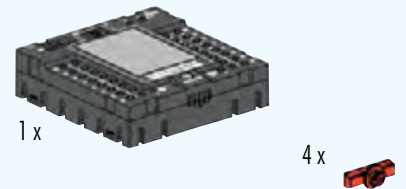
**6****7**

- TXT Controller (Art.-Nr. 522429) nicht im Baukasten enthalten
- TXT Controller (Art.-Nr. 522429) not included in the modular kit
- TXT Controller (Art.-Nr. 522429) n'est pas contenue dans le kit
- TXT Controller (Art.-Nr. 522429) niet in de bouwdoos opgenomen
- TXT Controller (Art.-Nr. 522429) no está incluido en el conjunto
- TXT Controller (Art.-Nr. 522429) não contido no sistema de construção por blocos
- TXT Controller (Art.-Nr. 522429) non incluso nella scatola di montaggio
- TXT Controller (Art.-Nr. 522429) не входит в комплект конструктора
- TXT Controller (Art.-Nr. 522429) 不包含在组件

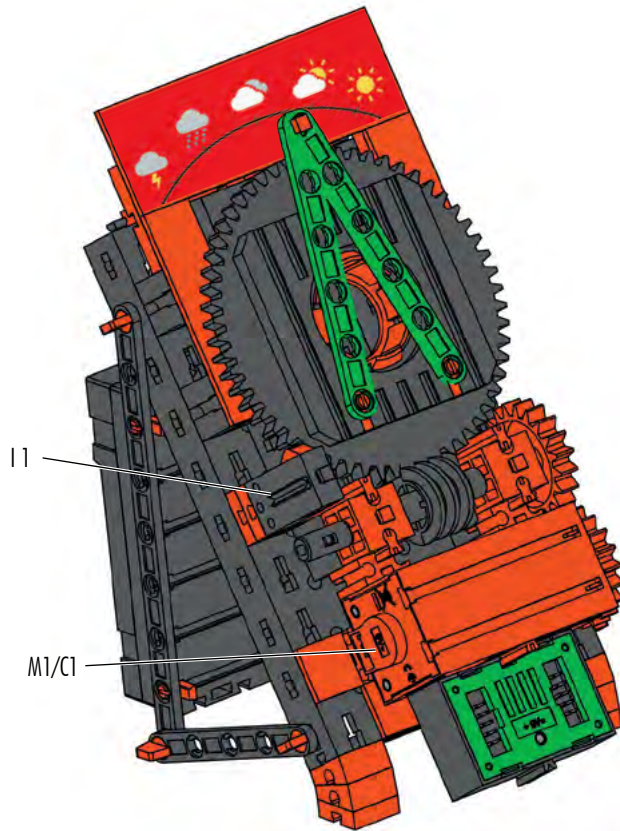

Schaltplan  
Circuit diagram  
Plan électrique

Schakelschema  
Diagrama de circuitos  
Plano elétrico de ligação

Schema elettrico  
Схема подключения  
电路图

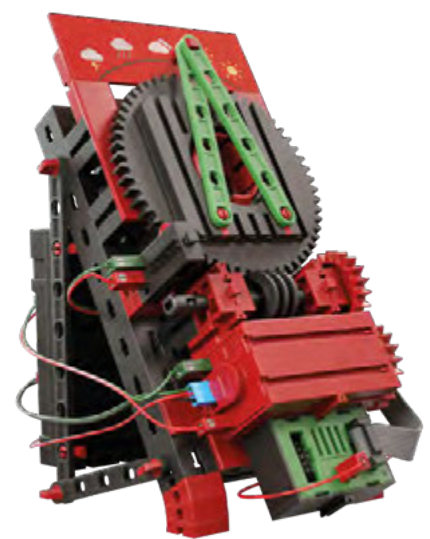
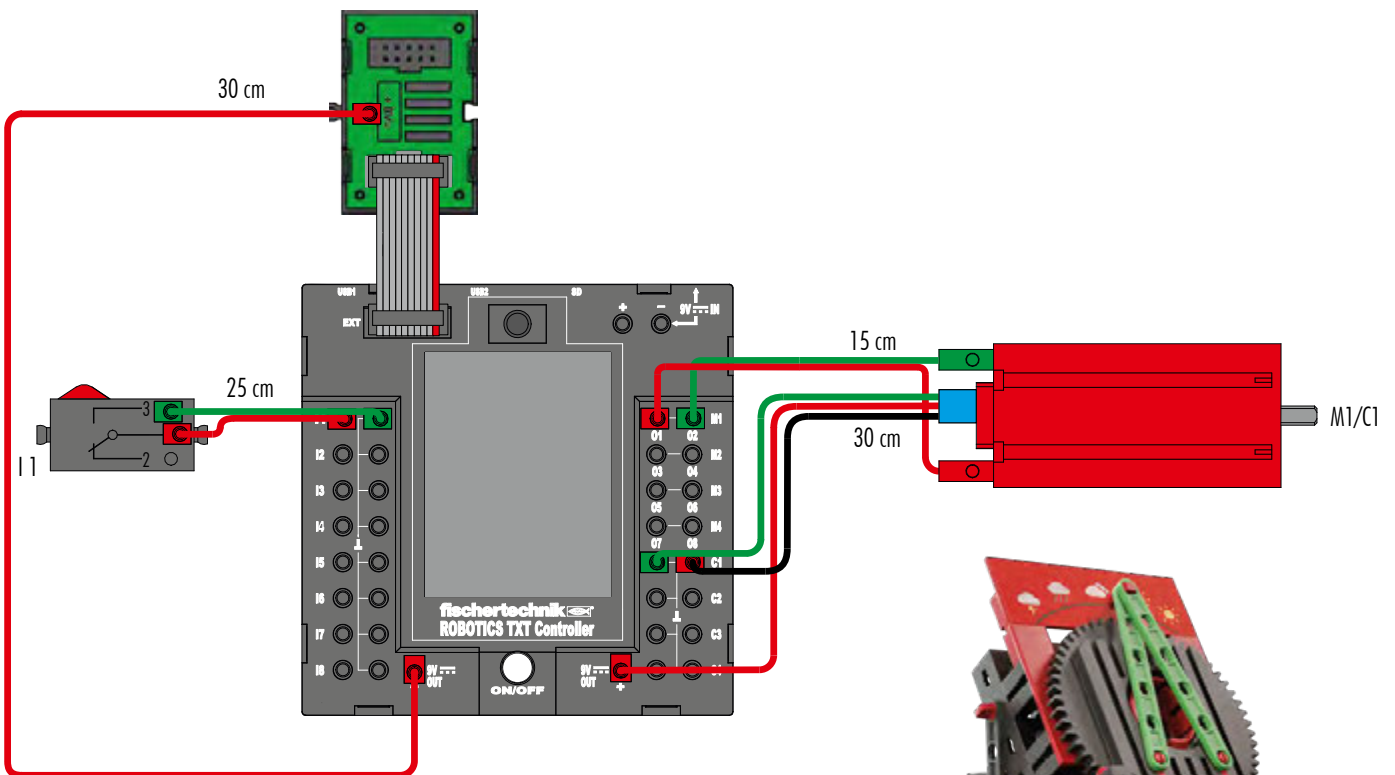



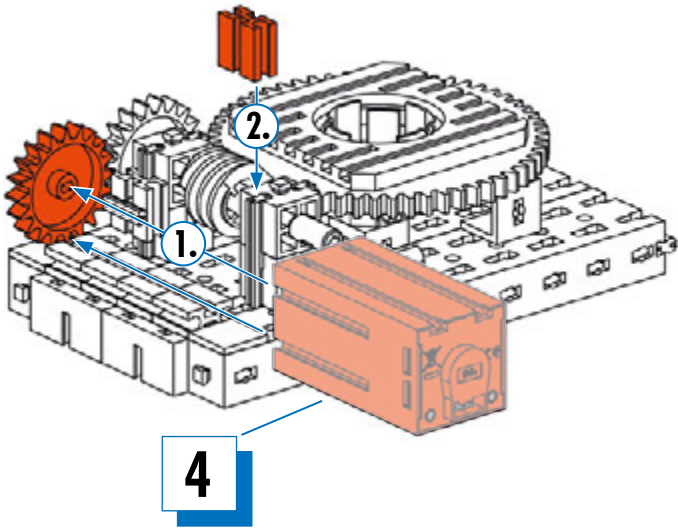





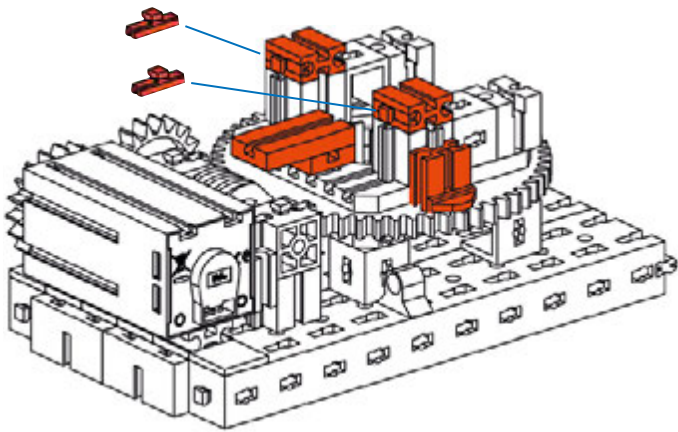
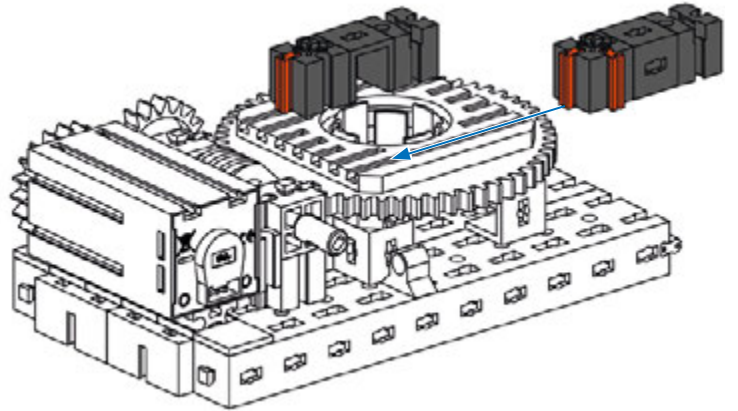





**5** 1x  1x 

**6** 2x  2x  3x  15 2x 



**7** 2x  3x  1x  1x  1x 

**8** 1x  1x  30 2x  2x  1x  1x  2x

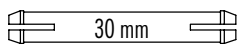
 30 mm

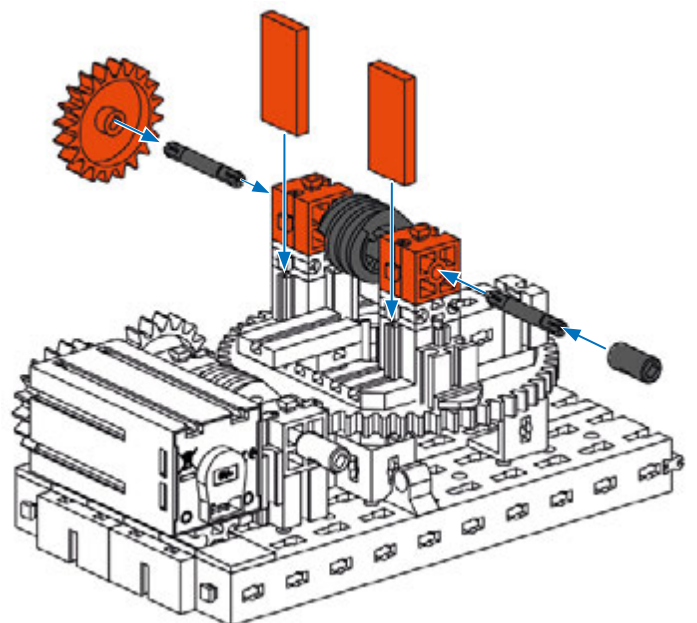

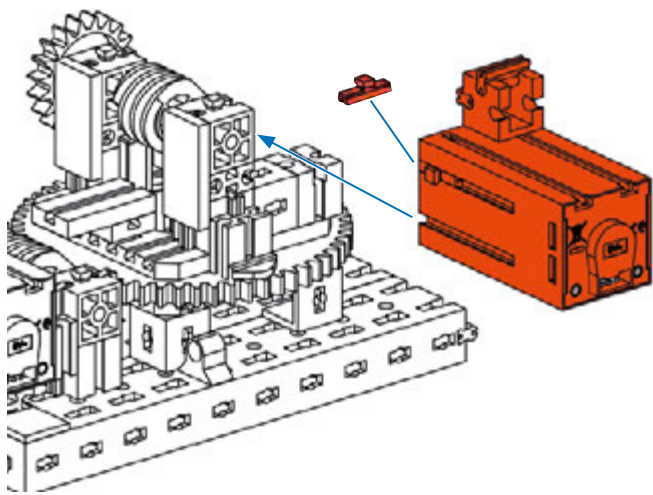

**9**

- 1x [Red 1x3 Technic Brick]
- 1x [Red 1x3 Technic Brick with 2 holes]
- 1x [Red 1x2 Technic Pin]
- 15 [Red 1x2 Technic Pin]
- 2x [Red 1x2 Technic Pin]

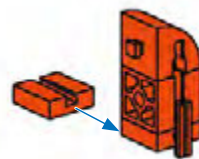

**10**

- 1x [Red 1x2 Technic Pin]
- 1x [Red 1x2 Technic Pin]
- 2x [Red 1x2 Technic Pin]
- 1x [Red 1x2 Technic Pin]

**11**

- 1x [Grey 1x2 Technic Pin]
- 1x [Red 1x2 Technic Pin]
- 30 [Red 1x2 Technic Pin]
- 1x [Red 1x2 Technic Pin]
- 15 [Red 1x2 Technic Pin]

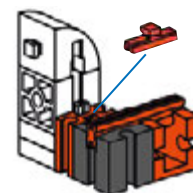

**11**

**12**

- 1x [Red 1x2 Technic Pin]
- 15 [Red 1x2 Technic Pin]

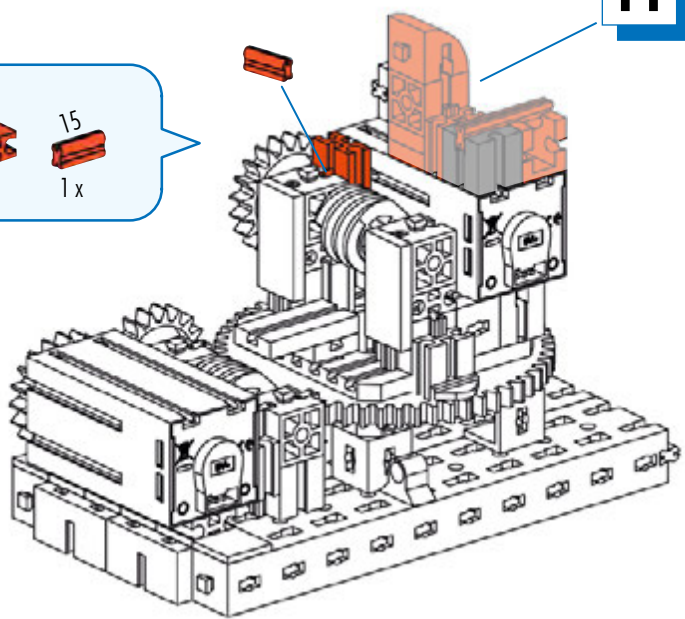



16

- 2 x
- 1 x
- 3 x
- 1 x
- 1 x
- 1 x
- 1 x
- 1 x
- 1 x
- 15
- 2 x
- 1 x
- 1 x

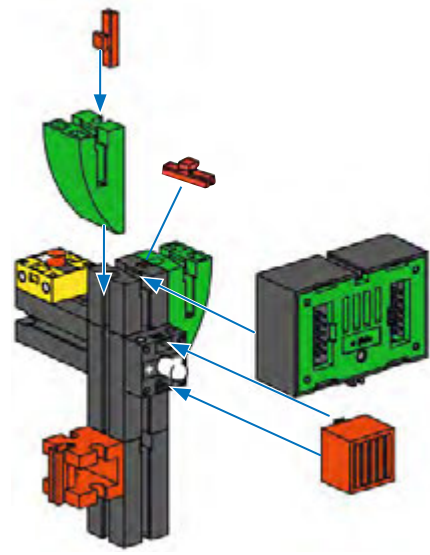

16

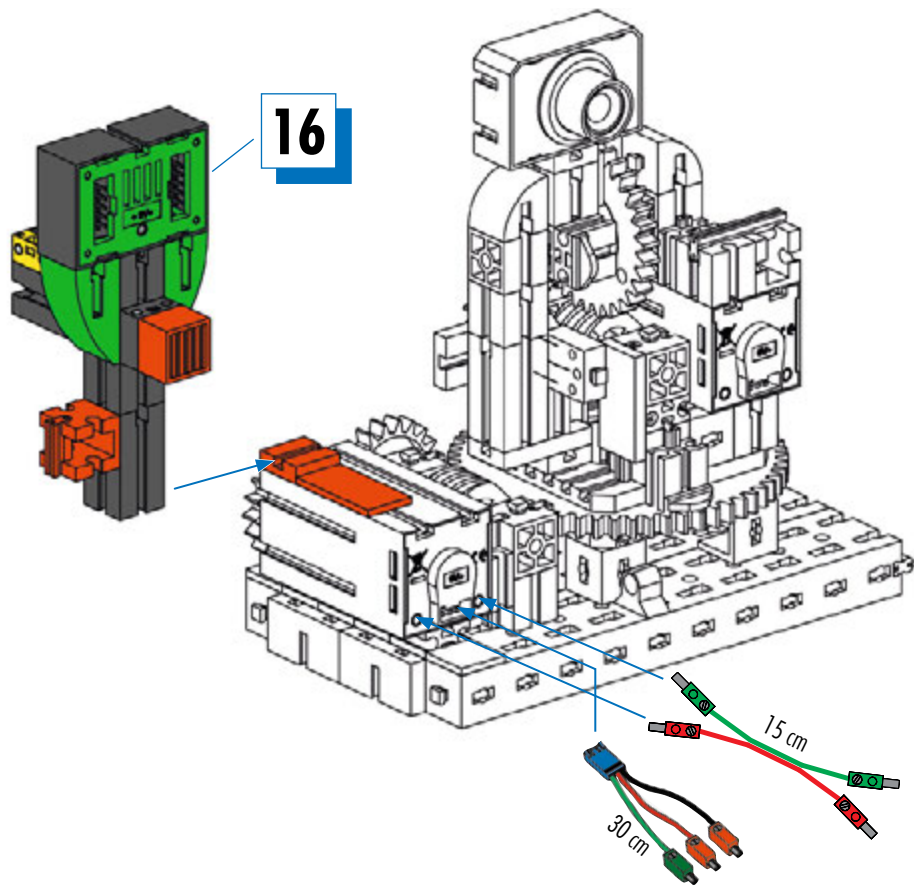

17

- 1 x
- 1 x
- 1 x
- 1 x

18

- 
- 4 x
- 4 x
- 2 x
- 3 x

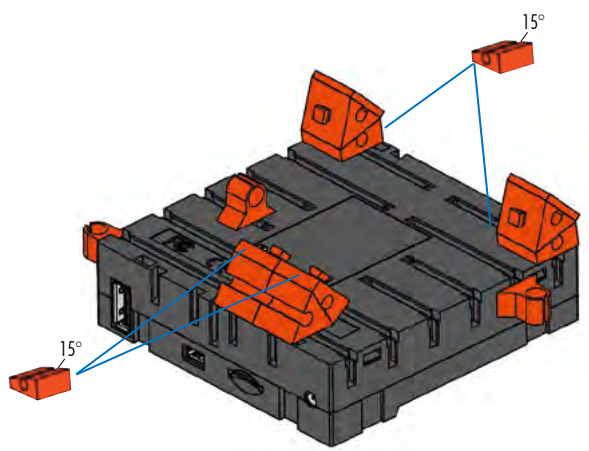

- TXT Controller (Art.-Nr. 522429) nicht im Baukasten enthalten
- TXT Controller (Art.-Nr. 522429) not included in the modular kit
- TXT Controller (Art.-Nr. 522429) n'est pas contenue dans le kit
- TXT Controller (Art.-Nr. 522429) niet in de bouwdoos opgenomen
- TXT Controller (Art.-Nr. 522429) no está incluido en el conjunto
- TXT Controller (Art.-Nr. 522429) não contido no sistema de construção por blocos
- TXT Controller (Art.-Nr. 522429) non incluso nella scatola di montaggio
- TXT Controller (Art.-Nr. 522429) не входит в комплект конструктора
- TXT Controller (Art.-Nr. 522429) 不包含在组件



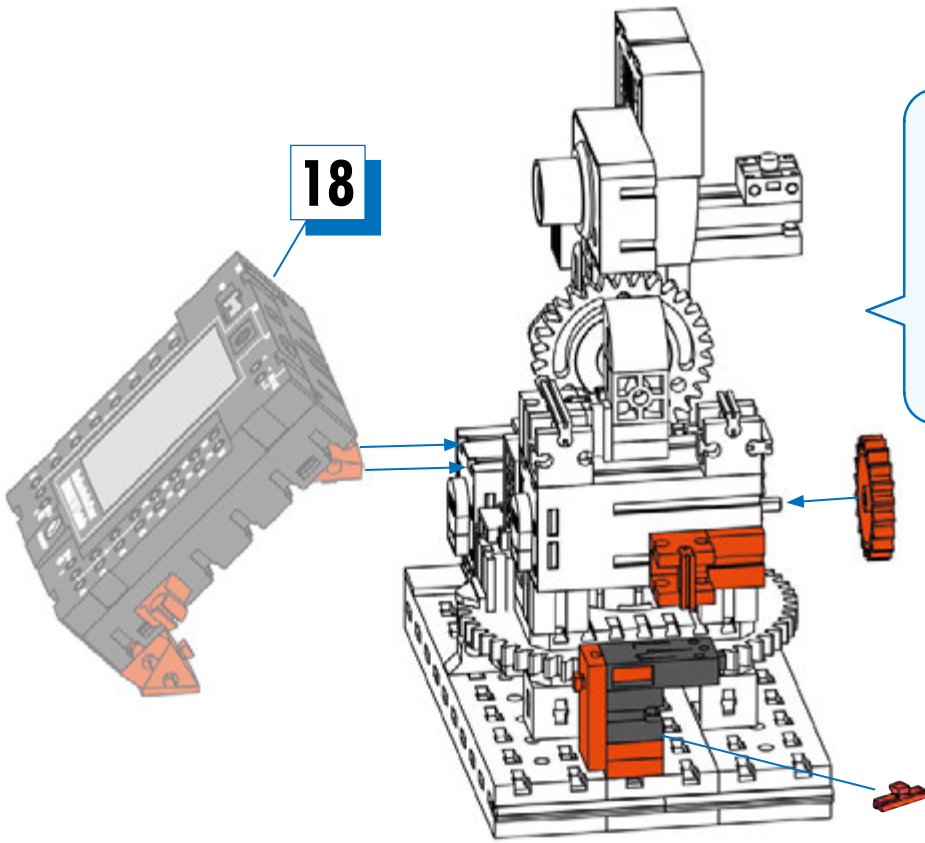

**19**

	1x	1x
	3x	
		1x
	1x	
		1x
		1x

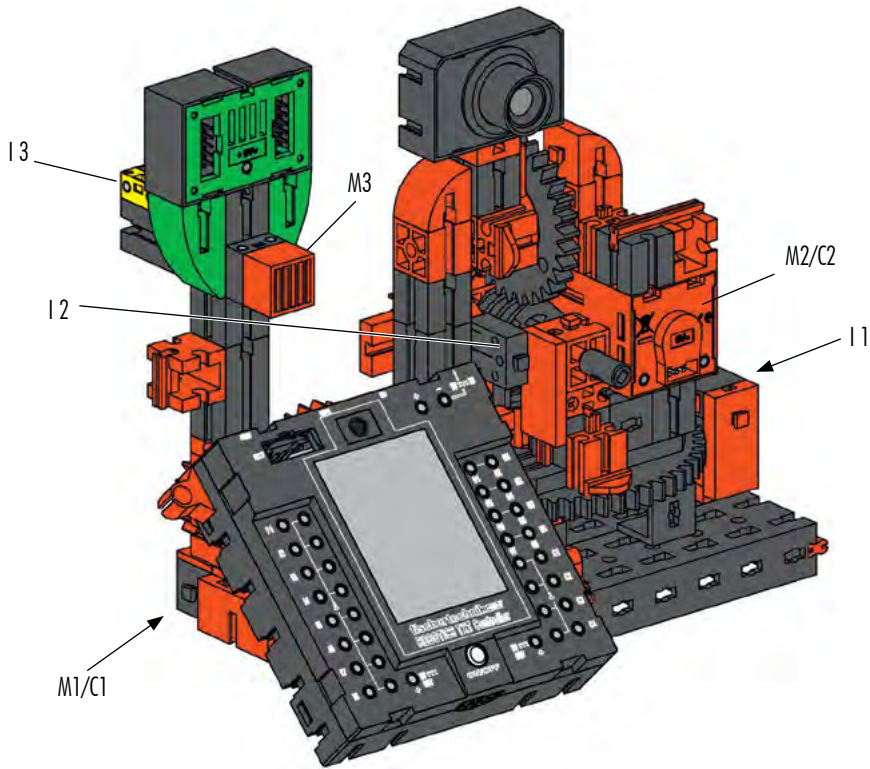

Schaltplan  
Circuit diagram  
Plan électrique

Schakelschema  
Diagrama de circuitos  
Plano elétrico de ligação

Schema elettrico  
Схема подключения  
电路图

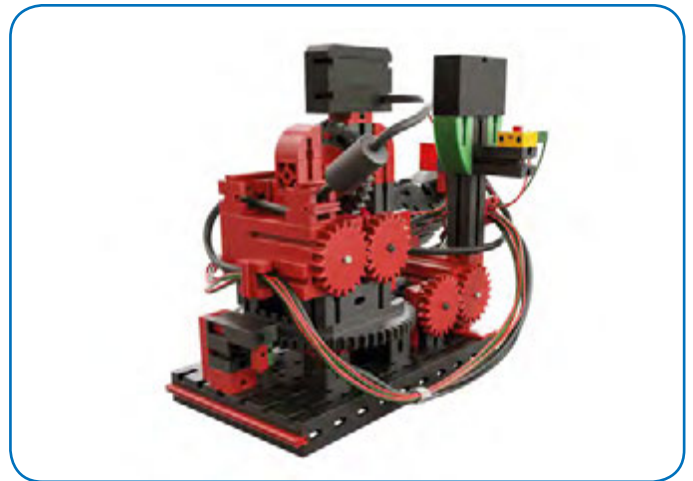
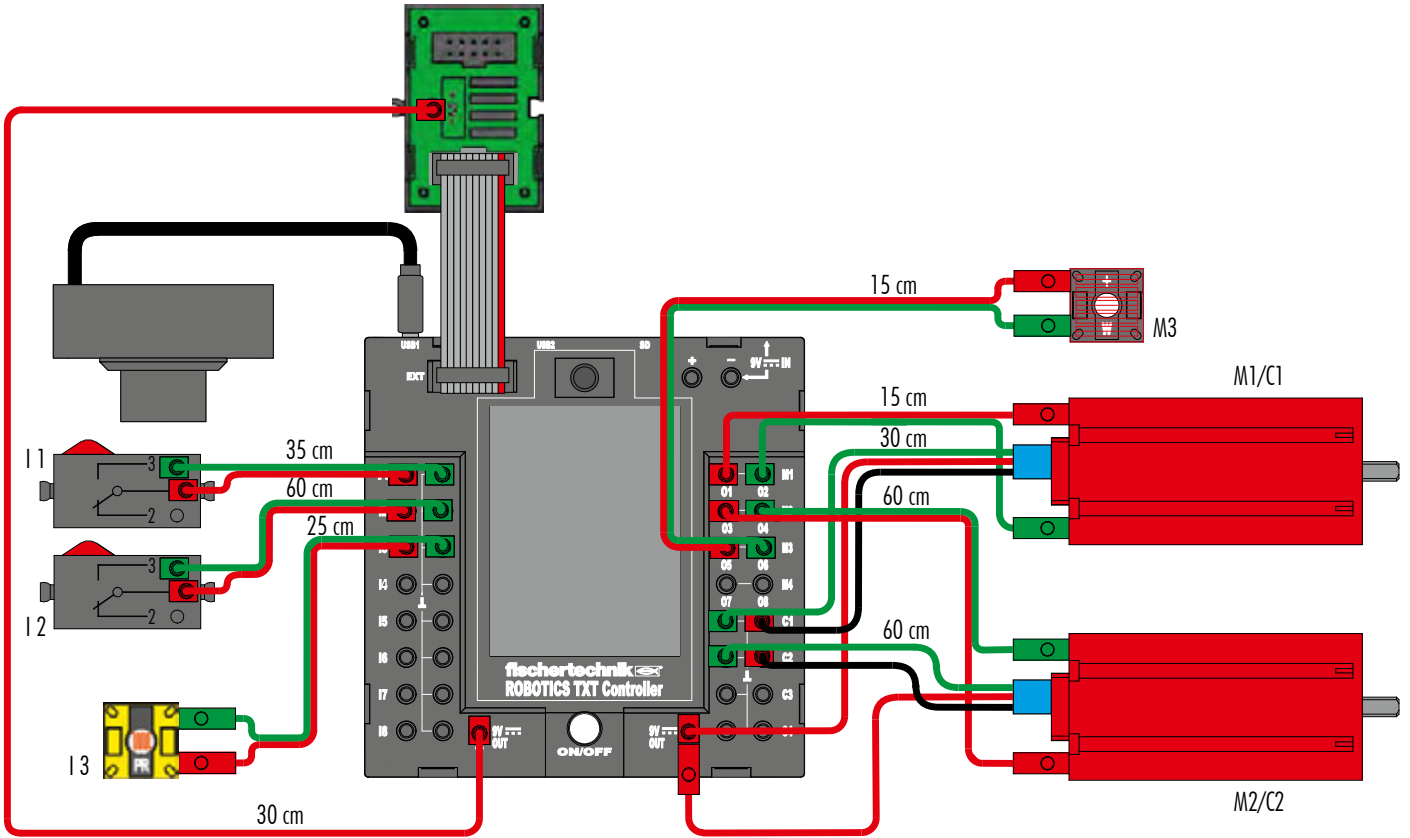

Empfohlene Aufbewahrung:	3 x Aufbewahrungssystem Art.-Nr. 94828
Recommended storage:	3 x storage system Art No. 94828
Stockage conseillé :	3 x système de stockage Art n° 94828
Bewaaradvies:	3 x bewaarsysteem art.-nr. 94828
Consejos para guardar el producto:	3 x almacenamiento Art. N° 94828
Conservação recomendada:	3 x sistema de conservação n.º de art. 94828
Conservazione consigliata:	3 sistemi di conservazione, cod. prod. 94828
Рекомендуемое хранение:	3 x бокса для хранения. Арт.№ 94 828
推荐的保存方式 :	3 个产品号为 94 828 的保存系统

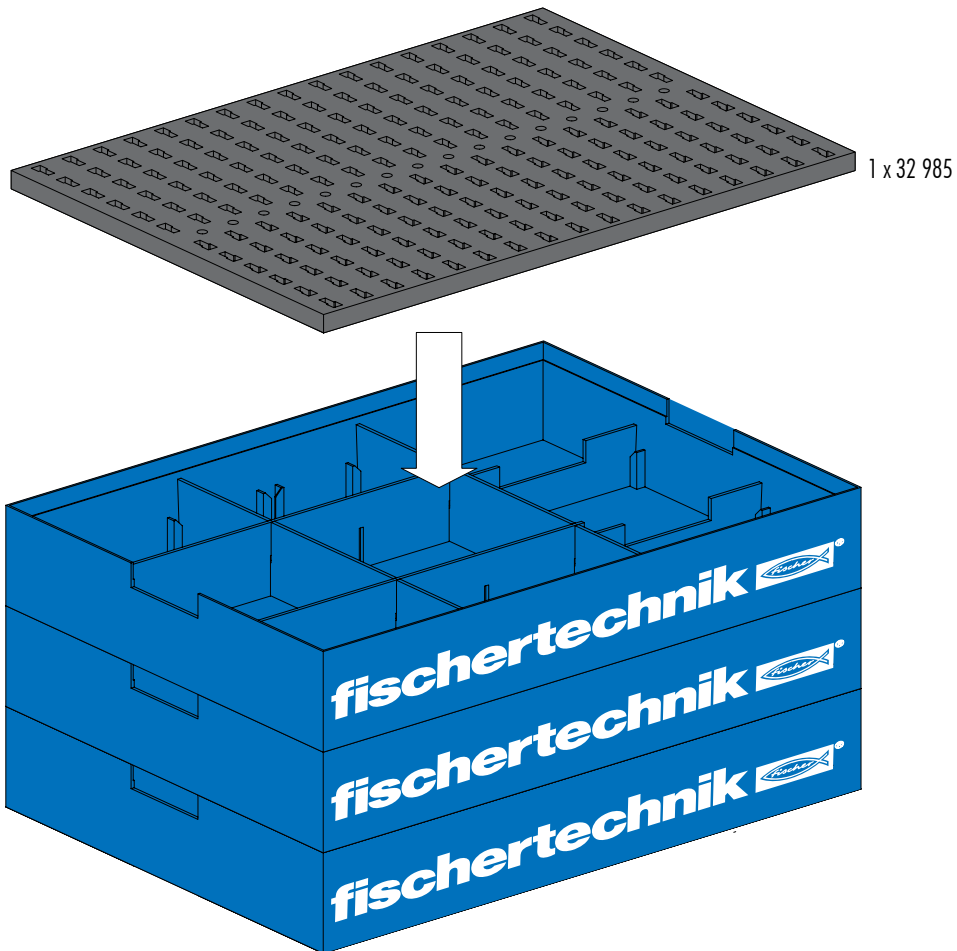

Sortiervorschlag / Storage suggestion / Suggestion de classement / Sorteervoorstel / Propuesta de clasificación / Proposta de divisão / Proposta di sistemazione / Рекомендации по сортировке / 保存系统的分类建议:

[www.fischertechnik.de/Sortiervorschläge](http://www.fischertechnik.de/Sortiervorschläge)



Hinweise zum Umweltschutz / Instructions for Environmental Protection / Remarques de protection de l'environnement / Bescherming van het milieu / Notas con respecto a la protección del medio ambiente / Instruções para a proteção do meio ambiente / Indicazioni sulla tutela ambientale / Указания по охране окружающей среды / 有关环保的提示 :

[www.fischertechnik.de/environment](http://www.fischertechnik.de/environment)



**fischertechnik** 

**ROBOTICS**

fischertechnik GmbH  
Klaus-Fischer-Str. 1  
72178 Waldachtal  
Germany

Phone: +49 74 43/12-43 69  
Fax: +49 74 43/12-45 91

info@fischertechnik.de  
www.fischertechnik.de

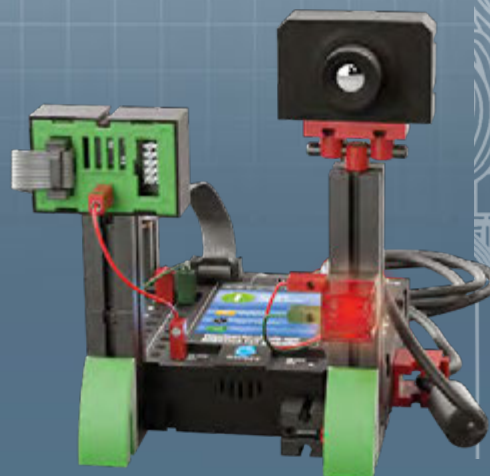
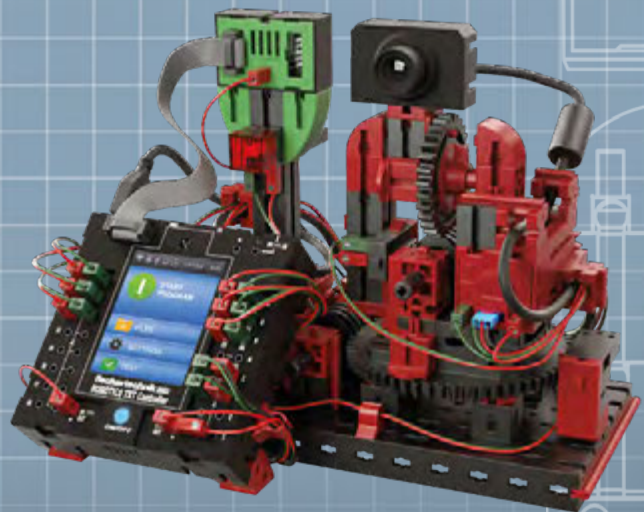
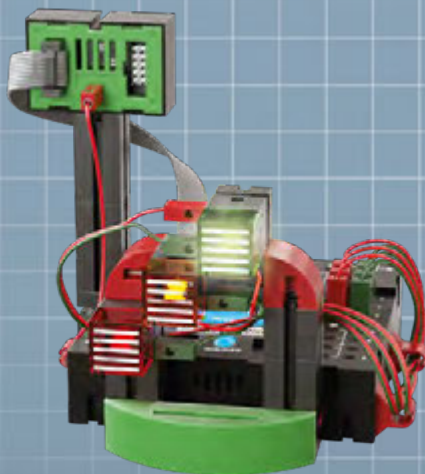
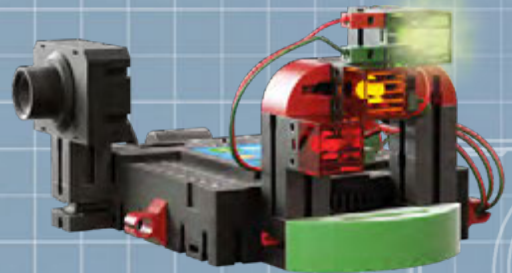
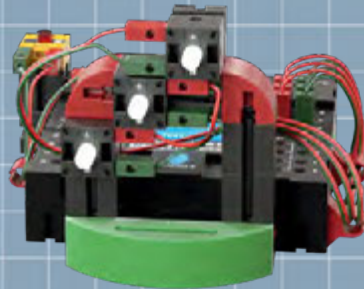

167941 - 06/18 - Co - Printed in Germany - Technische Änderungen vorbehalten - Subject to technical modifications

**TXT Smart Home**  
**Robotics Sensor Station IoT**

**6 MODELS**